

PRODUCT CATALOGUE 2023



**INNOVATING BEYOND
PIONEERING AHEAD**

-  +86 189 6858 6665
-  echo@wencerl.com
-  www.wencerl.com
-  Qianyangxia Village, Wenqiao Town, Wenling City, Zhejiang Province, the PRC



TN□□

三角形有孔



TNGG 16 04 04 - □□

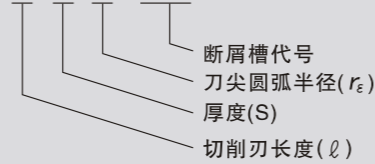

A 车刀系列

B 铣刀系列

C 槽刀系列

D 螺纹刀片系列

刀片外形	型号	尺寸				通用			CVD			金属陶瓷		
		φD	S	φd	R	ZP50	ZP55	CP10	CP20	CP25	CK30	T20P	T10	T20
	160402R-C	9.525	4.76	3.81	0.2									
	160404R-C	9.525	4.76	3.81	0.4									
	160408R-C	9.525	4.76	3.81	0.8									
	160402L-C	9.525	4.76	3.81	0.2									
	160404L-C	9.525	4.76	3.81	0.4									
	160408L-C	9.525	4.76	3.81	0.8									
		160401R-S	9.525	4.76	3.81	0.1								
160402R-S		9.525	4.76	3.81	0.2									
160404R-S		9.525	4.76	3.81	0.4									
160408R-S		9.525	4.76	3.81	0.8									
160401L-S		9.525	4.76	3.81	0.1									
160402L-S		9.525	4.76	3.81	0.2									
160404L-S		9.525	4.76	3.81	0.4									
160408L-S		9.525	4.76	3.81	0.8									
	160402R-F	9.525	4.76	3.81	0.2									
	160404R-F	9.525	4.76	3.81	0.4									
	160408R-F	9.525	4.76	3.81	0.8									
	160402L-F	9.525	4.76	3.81	0.2									
	160404L-F	9.525	4.76	3.81	0.4									
	160408L-F	9.525	4.76	3.81	0.8									
	160402-UL	9.525	4.76	3.81	0.2									

◆ 常备库存 ◇ 预定库存

TN□□

三角形有孔



TNGG 16 04 04 - □□

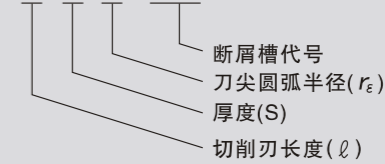

A 车刀系列

B 铣刀系列

C 槽刀系列

D 螺纹刀片系列

刀片外形	型号	尺寸				通用			CVD			金属陶瓷		
		φD	S	φd	R	ZP50	ZP55	CP10	CP20	CP25	CK30	T20P	T10	T20
	160402R-2G	9.525	4.76	3.81	0.2									
	160404R-2G	9.525	4.76	3.81	0.4									
	160408R-2G	9.525	4.76	3.81	0.8									
	160402L-2G	9.525	4.76	3.81	0.2									
	160404L-2G	9.525	4.76	3.81	0.4									
	160408L-2G	9.525	4.76	3.81	0.8									
		160402R/L-P	9.525	4.76	3.81	0.2								
160404R/L-P		9.525	4.76	3.81	0.4									
160408R/L-P		9.525	4.76	3.81	0.8									
160412R/L-P		9.525	4.76	3.81	1.2									
	160404R/L-W	9.525	4.76	3.81	0.4									
	160408R/L-W	9.525	4.76	3.81	0.8									
	160404R/L-G	9.525	4.76	3.81	0.4									
	160408R/L-G	9.525	4.76	3.81	0.8									
	120402R-C	9.525	4.76	3.81	0.2									
	160404R-C	9.525	4.76	3.81	0.4									
	160408R-C	9.525	4.76	3.81	0.8									
	160402L-C	9.525	4.76	3.81	0.2									
	160404L-C	9.525	4.76	3.81	0.4									
	160408L-C	9.525	4.76	3.81	0.8									
	220404	12.7	4.76	-	0.4									
	270408	15.875	4.76	-	0.8									
	330608	19.05	6.35	-	0.8									

◆ 常备库存 ◇ 预定库存

TN□□

三角形有孔



TNMG 16 04 04 - □□

断屑槽代号
刀尖圆弧半径(r_ϵ)
厚度(S)
切削刃长度(l)

A 车刀系列

B 铣刀系列

C 槽刀系列

D 螺纹刀片系列

刀片外形	型号	尺寸				通用		CVD					金属陶瓷		
		ϕD	S	ϕd	R	ZP50	ZP55	CP10	CP20	CP25	CK30	T20P	T10	T20	
	160404-MAS	9.525	4.76	3.81	0.4										
	160408-MAS	9.525	4.76	3.81	0.8										
	160412-MAS	9.525	4.76	3.81	1.2										
	270612-QR	15.875	6.35	6.35	1.2										
	160404R-FS	12.7	4.76	3.81	0.4										
	160408R-FS	12.7	4.76	3.81	0.8										
	160404L-FS	12.7	4.76	3.81	0.4										
	160408L-FS	12.7	4.76	3.81	0.8										
	160404-MT	9.525	4.76	3.81	0.4										
	160408-MT	9.525	4.76	3.81	0.8										
	160404R-VF	9.525	3.97	3.81	0.4										
	160404L-VF	9.525	3.97	3.81	0.4										
	160408R-VF	9.525	3.97	3.81	0.8										
	160408L-VF	9.525	3.97	3.81	0.8										
	160404-NN	9.525	4.76	3.81	0.4										
	160408-NN	9.525	4.76	3.81	0.8										

◆ 常备库存 ◇ 预定库存

TN□□

三角形有孔



TNMG 16 04 04 - □□

断屑槽代号
刀尖圆弧半径(r_ϵ)
厚度(S)
切削刃长度(l)

A 车刀系列

B 铣刀系列

C 槽刀系列

D 螺纹刀片系列

刀片外形	型号	尺寸				通用		CVD					金属陶瓷		
		ϕD	S	ϕd	R	ZP50	ZP55	CP10	CP20	CP25	CK30	T20P	T10	T20	
	160404-MSS	9.525	4.76	3.18	0.4										
	160408-MSS	9.525	4.76	3.18	0.8										
	160412-MSS														
	160404-HQJ	9.525	4.76	3.18	0.4										
	160408-HQJ	9.525	4.76	3.18	0.8										
	160412-HQJ	9.525	4.76	3.18	1.2										
	160404-TSD	9.525	4.76	3.81	0.4										
	160408-TSD	9.525	4.76	3.81	0.8										
	160404-TMD	9.525	4.76	3.18	0.4										
	160408-TMD	9.525	4.76	3.18	0.8										
	160412-TMD	9.525	4.76	3.18	1.2										
	160404-HA	9.525	4.76	3.81	0.4										
	160408-HA	9.525	4.76	3.81	0.8										
	160404-HMK	9.525	4.76	3.81	0.4										
	160408-HMK	9.525	4.76	3.81	0.8										
	160404-PM	9.525	4.76	3.18	0.4										
	160408-PM	9.525	4.76	3.18	0.8										
	220404-PM	12.7	4.76	5.16	0.4										
	220408-PM	12.7	4.76	5.16	0.8										

◆ 常备库存 ◇ 预定库存

TP□□

三角形有孔



TPMT 11 03 04 - □□

断屑槽代号
刀尖圆弧半径(r_ϵ)
厚度(S)
切削刃长度(l)

刀片外形	型号	尺寸				通用			CVD			金属陶瓷		
		ϕD	S	ϕd	R	ZP50	ZP55	CP10	CP20	CP25	CK30	T20P	T10	T20
	080202R-W08	4.76	2.38	2.3	0.2									
	080204R-W08	4.76	2.38	2.3	0.4									
	090202R-W15	5.56	2.38	2.6	0.2									
	090204R-W15	5.56	2.38	2.6	0.4									
	110302R-W15	6.35	3.18	3.3	0.2									
	110304R-W15	6.35	3.18	3.3	0.4									
	16T302R-W15	9.525	3.97	4.4	0.2									
	16T304R-W15	9.525	3.97	4.4	0.4									
	080202L-W08	4.76	2.38	2.3	0.2									
	080204L-W08	4.76	2.38	2.3	0.4									
	090202L-W15	5.56	2.38	2.6	0.2									
	090204L-W15	5.56	2.38	2.6	0.4									
	110302L-W15	6.35	3.18	3.3	0.2									
	110304L-W15	6.35	3.18	3.3	0.4									
	16T302L-W15	9.525	3.97	4.4	0.2									
	16T304L-W15	9.525	3.97	4.4	0.4									

◆常备库存 ◇预定库存

TP□□

三角形有孔



TPMT 11 03 04 - □□

断屑槽代号
刀尖圆弧半径(r_ϵ)
厚度(S)
切削刃长度(l)

刀片外形	型号	尺寸				通用			CVD			金属陶瓷		
		ϕD	S	ϕd	R	ZP50	ZP55	CP10	CP20	CP25	CK30	T20P	T10	T20
	110302R-H	6.35	3.18	3.3	0.2									
	110304R-H	6.35	3.18	3.3	0.4									
	110302L-H	6.35	3.18	3.3	0.2									
	110304L-H	6.35	3.18	3.3	0.4									
	080201R	4.76	2.38	2.3	0.1									
	080202R	4.76	2.38	2.3	0.2									
	090202R	5.56	2.38	3	0.2									
	090204R	5.56	2.38	3	0.4									
	110302R	6.35	3.18	3.3	0.2									
	110304R	6.35	3.18	3.3	0.4									
	160302R	9.525	3.97	4.4	0.2									
	160304R	9.525	3.97	4.4	0.4									
	080201L	4.76	2.38	2.3	0.1									
	080202L	4.76	2.38	2.3	0.2									
	090202L	5.56	2.38	3	0.2									
	090204L	5.56	2.38	3	0.4									
	110302L	6.35	3.18	3.3	0.2									
	110304L	6.35	3.18	3.3	0.4									
160302L	9.525	3.97	4.4	0.2										
160304L	9.525	3.97	4.4	0.4										
	090202R/L-FE	5.56	2.38	2.8	0.2									
	090204R/L-FE	5.56	2.38	2.8	0.4									
	110302R/L-FE	6.35	3.18	3.4	0.2									
	110304R/L-FE	6.35	3.18	3.4	0.4									
	110304-PSD	6.35	3.18	3.4	0.4									
	110308-PSD	6.35	3.18	3.4	0.8									
	110302-HQJ	6.35	3.18	2.8	0.2									
	110304-HQJ	6.35	3.18	2.8	0.4									
	110308-HQJ	6.35	3.18	2.8	0.8									

◆常备库存 ◇预定库存

A 车刀系列

B 铣刀系列

C 槽刀系列

D 螺纹刀片系列

A 车刀系列

B 铣刀系列

C 槽刀系列

D 螺纹刀片系列

TB□□

三角形有孔



TPMT 11 03 04 - □□

断屑槽代号
刀尖圆弧半径(r_ϵ)
厚度(S)
切削刃长度(l)

A 车刀系列

B 铣刀系列

C 槽刀系列

D 螺纹刀片系列

刀片外形	型号	尺寸				通用		CVD					金属陶瓷		
		ϕD	S	ϕd	R	ZP50	ZP55	CP10	CP20	CP25	CK30	T20P	T10	T20	
	060201R	3.97	1.59	2.3	0.1										
	060202R	3.97	1.59	2.3	0.2										
	060204R	3.97	1.59	2.3	0.4										
	060201L	3.97	1.59	2.3	0.1										
	060202L	3.97	1.59	2.3	0.2										
	060204L	3.97	1.59	2.3	0.4										
		3.97	1.59	2.3	0.2										
	060104-DP	3.97	1.59	2.3	0.4										

◆常备库存 ◇预定库存

TC□□

三角形有孔



TCGT 09 02 02 - □□

断屑槽代号
刀尖圆弧半径(r_ϵ)
厚度(S)
切削刃长度(l)

A 车刀系列

B 铣刀系列

C 槽刀系列

D 螺纹刀片系列

刀片外形	型号	尺寸				通用		CVD					金属陶瓷		
		ϕD	S	ϕd	R	ZP50	ZP55	CP10	CP20	CP25	CK30	T20P	T10	T20	
	06101R	3.97	1.59	2.3	0.1										
	06102R	3.97	1.59	2.3	0.2										
	06104R	3.97	1.59	2.3	0.4										
	090202R	5.56	2.38	2.5	0.2										
	090204R	5.56	2.38	2.5	0.4										
	110202R	6.35	2.38	2.8	0.2										
	110204R	6.35	2.38	2.8	0.4										
	16T302R	9.525	3.97	4.4	0.2										
	16T304R	9.525	3.97	4.4	0.4										
		110202L-W15	6.35	2.38	2.8	0.2									
110204L-W15		6.35	2.38	2.8	0.4										
	TCEX090204-UX	5.56	2.38	2.5	0.4										
	TCGT16T304-UX	9.525	3.97	4.4	0.4										
	TCGT16T308-UX	9.525	3.97	4.4	0.8										
	090202-AK	5.56	2.38	2.5	0.2										
	090204-AK	5.56	2.38	2.5	0.4										
	110202-AK	6.35	2.38	2.8	0.2										
	110204-AK	6.35	2.38	2.8	0.4										
	16T302-AK	9.525	3.97	4.4	0.2										
	16T304-AK	9.525	3.97	4.4	0.4										
	16T308-AK	9.525	3.97	4.4	0.8										

◆常备库存 ◇预定库存

TC□□

三角形有孔



TCMT 09 02 02 - □□

断屑槽代号
刀尖圆弧半径(r_ϵ)
厚度(S)
切削刃长度(ℓ)

刀片外形	型号	尺寸				通用		CVD					金属陶瓷		
		ϕD	S	ϕd	R	ZP50	ZP55	CP10	CP20	CP25	CK30	T20P	T10	T20	
	110202	6.35	2.38	2.8	0.2										
	110204	6.35	2.38	2.8	0.4										
	110208	6.35	2.38	2.8	0.8										
	110304	6.35	3.18	2.8	0.4										
	16T304	9.525	3.18	4.4	0.4										
	16T308	9.525	3.18	4.4	0.8										
	110304-MV	6.35	2.38	3.4	0.4										
	110308-MV	6.35	2.38	3.4	0.8										
	090202-HQJ	5.56	2.38	2.5	0.2										
	090204-HQJ	5.56	2.38	2.5	0.4										
	090208-HQJ	5.56	2.38	2.5	0.8										
	110202-HQJ	6.35	2.38	2.8	0.2										
	110204-HQJ	6.35	2.38	2.8	0.4										
	110208-HQJ	6.35	2.38	2.8	0.8										
	16T304-HQJ	9.525	3.97	4.4	0.4										
	16T308-HQJ	9.525	3.97	4.4	0.8										
	110202-PSD	6.35	2.38	2.8	0.2										
110204-PSD	6.35	2.38	2.8	0.4											
110208-PSD	6.35	2.38	2.8	0.8											

◆常备库存 ◇预定库存

TC□□

三角形有孔



TCMT 09 02 02 - □□

断屑槽代号
刀尖圆弧半径(r_ϵ)
厚度(S)
切削刃长度(ℓ)

刀片外形	型号	尺寸				通用		CVD					金属陶瓷		
		ϕD	S	ϕd	R	ZP50	ZP55	CP10	CP20	CP25	CK30	T20P	T10	T20	
	090204-24D	5.56	2.38	2.5	0.4										
	110204-24D	6.35	2.38	2.8	0.4										
	110204-MTT	6.35	2.38	2.8	0.4										
	090204-PM	5.56	2.38	2.5	0.4										
	110304-PM	6.35	3.18	2.8	0.4										
	110308-PM	6.35	3.18	2.8	0.8										
	110204-NN	6.35	2.38	2.8	0.4										
	110208-NN	6.35	2.38	2.8	0.8										
	16T304-NN	9.525	3.97	4.4	0.4										
	16T308-NN	9.525	3.97	4.4	0.8										
	16T304-HMP	9.525	3.97	4.4	0.4										
	16T308-HMP	9.525	3.97	4.4	0.8										

◆常备库存 ◇预定库存

CC□□

菱形有孔



CCGT 06 02 02 - □□

断屑槽代号
刀尖圆弧半径(r_ϵ)
厚度(S)
切削刃长度(ℓ)

A 车刀系列

B 铣刀系列

C 槽刀系列

D 螺纹刀片系列

刀片外形	型号	尺寸				通用			CVD			金属陶瓷			
		ϕD	S	ϕd	R	ZP50	ZP55	CP10	CP20	CP25	CK30	T20P	T10	T20	
	060202ER-U	6.35	2.38	2.8	0.2										
	060204ER-U	6.35	2.38	2.8	0.4										
	09T302ER-U	9.525	3.97	4.4	0.2										
	09T304ER-U	9.525	3.97	4.4	0.4										
	060202EL-U	6.35	2.38	2.8	0.2										
	060204EL-U	6.35	2.38	2.8	0.4										
	09T302EL-U	9.525	3.97	4.4	0.2										
	09T304EL-U	9.525	3.97	4.4	0.4										
	030101R	3.5	1.4	1.9	0.1										
	030102R	3.5	1.4	1.9	0.2										
	030104R	3.5	1.4	1.9	0.4										
	040102R	4.3	1.8	2.3	0.2										
	040104R	4.3	1.8	2.3	0.4										
	030101L	3.5	1.4	1.9	0.1										
	030102L	3.5	1.4	1.9	0.2										
	030104L	3.5	1.4	1.9	0.4										
	040102L	4.3	1.8	2.3	0.2										
	040104L	4.3	1.8	2.3	0.4										
	060202R-W15	6.35	2.38	2.8	0.2										
	060204R-W15	6.35	2.38	2.8	0.4										
	060208R-W15	6.35	2.38	2.8	0.8										
	09T302R-W20	9.525	3.97	4.4	0.2										
	09T304R-W20	9.525	3.97	4.4	0.4										
	09T308R-W20	9.525	3.97	4.4	0.8										
	060202L-W15	6.35	2.38	2.8	0.2										
	060204L-W15	6.35	2.38	2.8	0.4										
	060208L-W15	6.35	2.38	2.8	0.8										
	09T302L-W20	9.525	3.97	4.4	0.2										
	09T304L-W20	9.525	3.97	4.4	0.4										
	09T308L-W20	9.525	3.97	4.4	0.8										
		09T302-YL	9.525	3.97	4.4	0.2									
		09T304-YL	9.525	3.97	4.4	0.4									
	060202-AK	6.35	2.38	2.8	0.2										
	060204-AK	6.35	2.38	2.8	0.4										
	060208-AK	6.35	2.38	2.8	0.8										
	09T302-AK	9.525	3.97	4.4	0.2										
	09T304-AK	9.525	3.97	4.4	0.4										
	09T308-AK	9.525	3.97	4.4	0.8										
	120402-AK	12.7	4.76	5.5	0.2										
	120404-AK	12.7	4.76	5.5	0.4										
	120408-AK	12.7	4.76	5.5	0.8										

◆常备库存 ◇预定库存

CC□□

菱形有孔



CCMT 06 02 02 - □□

断屑槽代号
刀尖圆弧半径(r_ϵ)
厚度(S)
切削刃长度(ℓ)

A 车刀系列

B 铣刀系列

C 槽刀系列

D 螺纹刀片系列

刀片外形	型号	尺寸				通用			CVD			金属陶瓷		
		ϕD	S	ϕd	R	ZP50	ZP55	CP10	CP20	CP25	CK30	T20P	T10	T20
	060202	6.35	2.38	2.38	0.2									
	060204	6.35	2.38	2.38	0.4									
	060208	6.35	2.38	2.38	0.8									
	09T302	9.525	3.97	3.97	0.2									
	09T304	9.525	3.97	3.97	0.4									
	09T308	9.525	3.97	3.97	0.8									
	120404	12.7	4.76	4.76	0.4									
	120408	12.7	4.76	4.76	0.8									
	060202-HQJ	6.35	2.38	2.8	0.2									
	060204-HQJ	6.35	2.38	2.8	0.4									
	060208-HQJ	6.35	2.38	2.8	0.8									
	09T302-HQJ	9.525	3.97	4.4	0.2									
	09T304-HQJ	9.525	3.97	4.4	0.4									
	09T308-HQJ	9.525	3.97	4.4	0.8									
	060202-PSD	6.35	2.38	2.8	0.2									
	060204-PSD	6.35	2.38	2.8	0.4									
	060208-PSD	6.35	2.38	2.8	0.8									
	09T304-PSD	9.525	3.97	4.4	0.2									
	09T304-PSD	9.525	3.97	4.4	0.4									
	09T308-PSD	9.525	3.97	4.4	0.8									
	060202-24D	6.35	2.38	2.8	0.2									
	060204-24D	6.35	2.38	2.8	0.4									
	09T302-24D	9.525	3.97	4.4	0.2									
	09T304-24D	9.525	3.97	4.4	0.4									
	09T304-24D	9.525	3.97	4.4	0.4									
	09T308-24D	9.525	3.97	4.4	0.8									

◆常备库存 ◇预定库存

CC□□

菱形有孔



CCMT 06 02 02 - □□

断屑槽代号
刀尖圆弧半径(r_ϵ)
厚度(S)
切削刃长度(ℓ)

A 车刀系列

B 铣刀系列

C 槽刀系列

D 螺纹刀片系列

刀片外形	型号	尺寸				通用			CVD			金属陶瓷		
		ϕD	S	ϕd	R	ZP50	ZP55	CP10	CP20	CP25	CK30	T20P	T10	T20
	060204-MTT	6.35	2.38	2.8	0.4									
	09T304-MTT	6.35	2.38	2.8	0.4									
	060204-FGT	6.35	2.38	2.8	0.4									
	09T304-FGT	9.525	3.97	4.4	0.4									
	060204-PM	6.35	2.38	2.8	0.4									
	09T304-PM	9.525	3.97	4.4	0.4									
	09T308-PM	9.525	3.97	4.4	0.8									
	120404-PM	12.7	4.76	5.5	0.4									
	120408-PM	12.7	4.76	5.5	0.8									
	060204-NN	6.35	2.38	2.8	0.4									
	09T304-NN	9.525	3.97	4.4	0.4									
	09T308-NN	9.525	3.97	4.4	0.8									
	060204-HMP	6.35	2.38	2.8	0.4									
	09T302-HMP	9.525	3.97	4.4	0.2									
	09T308-HMP	9.525	3.97	4.4	0.8									
	120404-HMP	12.7	4.76	5.5	0.4									
	120408-HMP	12.7	4.76	5.5	0.8									
	120404-GK	12.7	4.76	5.5	0.4									
	120404-C25	12.7	4.76	5.16	0.4									
	120408-C25	12.7	4.76	5.16	0.8									

◆常备库存 ◇预定库存

EP□□

菱形有孔



EPGT 04 01 01 - □□

断屑槽代号
刀尖圆弧半径(r_ϵ)
厚度(S)
切削刃长度(ℓ)

A 车刀系列

B 铣刀系列

C 槽刀系列

D 螺纹刀片系列

刀片外形	型号	尺寸				通用			CVD			金属陶瓷		
		ϕD	S	ϕd	R	ZP50	ZP55	CP10	CP20	CP25	CK30	T20P	T10	T20
	040101R-W08	3.97	1.59	2.3	0.1									
	040102R-W08	3.97	1.59	2.3	0.2									
	040104R-W08	3.97	1.59	2.3	0.4									
	040101L-W08	3.97	1.59	2.3	0.1									
	040102L-W08	3.97	1.59	2.3	0.2									
	040104L-W08	3.97	1.59	2.3	0.4									

◆常备库存 ◇预定库存

WB□□

六角形有孔



WNMG 08 04 04 - □□

断屑槽代号
刀尖圆弧半径(r_e)
厚度(S)
切削刃长度(l)

A 车刀系列

B 铣刀系列

C 槽刀系列

D 螺纹刀片系列

刀片外形	型号	尺寸				通用		CVD			金属陶瓷			
		ϕD	S	ϕd	R	ZP50	ZP55	CP10	CP20	CP25	CK30	T20P	T10	T20
	WBGT													
	030101R-W08	3.97	1.59	2.3	0.1									
	030102R-W08	3.97	1.59	2.3	0.2									
	030104R-W08	3.97	1.59	2.3	0.4									
	060102R-W11	3.97	1.59	2.3	0.2									
	060104R-W11	3.97	1.59	2.3	0.4									
	080202R-W11	4.76	2.38	2.3	0.2									
	080204R-W11	4.76	2.38	2.3	0.4									
	030101L-W08	3.97	1.59	2.3	0.1									
	030102L-W08	3.97	1.59	2.3	0.2									
	030104L-W08	3.97	1.59	2.3	0.4									
	060102L-W11	3.97	1.59	2.3	0.2									
060104L-W11	3.97	1.59	2.3	0.4										
080202L-W11	4.76	2.38	2.3	0.2										
080204L-W11	4.76	2.38	2.3	0.4										
	WBGT													
	060102L-F	3.97	1.59	2.3	0.2									
060104L-F	3.97	1.59	2.3	0.4										
	WBMT													
	060102-DP	3.97	1.59	2.3	0.2									
060104-DP	3.97	1.59	2.3	0.4										

◆常备库存 ◇预定库存

DN□□

菱形有孔



DNMG 15 04 04 - □□

断屑槽代号
刀尖圆弧半径(r_e)
厚度(S)
切削刃长度(l)

A 车刀系列

B 铣刀系列

C 槽刀系列

D 螺纹刀片系列

刀片外形	型号	尺寸				通用		CVD			金属陶瓷			
		ϕD	S	ϕd	R	ZP50	ZP55	CP10	CP20	CP25	CK30	T20P	T10	T20
	DNMG													
	150404R-VF	12.7	4.76	5.16	0.4									
150404L-VF	12.7	4.76	5.16	0.4										
	DNMG													
	150404-MAS	12.7	4.76	5.16	0.4									
	150408-MAS	12.7	4.76	5.16	0.8									
150604-MAS	12.7	6.35	5.16	0.4										
150608-MAS	12.7	6.35	5.16	0.8										
	DNMG													
	150404-HQJ	12.7	4.76	5.16	0.4									
150408-HQJ	12.7	4.76	5.16	0.8										
	DNMG													
	150404-TSD	12.7	4.76	5.16	0.4									
150408-TSD	12.7	4.76	5.16	0.8										
	DNMG													
	150404-TMD	12.7	4.76	5.16	0.4									
	150408-TMD	12.7	4.76	5.16	0.8									
	150604-TMD	12.7	6.35	5.16	0.4									
150608-TMD	12.7	6.35	5.16	0.8										
	DNMG													
	150608-HMK	12.7	4.76	5.16	0.4									
150604-HMK	12.7	4.76	5.16	0.8										
	DNMG													
	150404-PM	12.7	4.76	5.16	0.4									
	150608-PM	12.7	4.76	5.16	0.8									
150612-PM	12.7	4.76	5.16	1.2										

◆常备库存 ◇预定库存

DC□□

菱形有孔



DCGT 12 04 04 - □□

断屑槽代号
刀尖圆弧半径(r_ϵ)
厚度(S)
切削刃长度(ℓ)

A 车刀系列

B 铣刀系列

C 槽刀系列

D 螺纹刀片系列

刀片外形	型号	尺寸				通用			CVD			金属陶瓷		
		ϕD	S	ϕd	R	ZP50	ZP55	CP10	CP20	CP25	CK30	T20P	T10	T20
	11T301R-U	9.525	3.97	4.4	0.1									
	11T302R-U	9.525	3.97	4.4	0.2									
	11T304R-U	9.525	3.97	4.4	0.4									
	11T301L-U	9.525	3.97	4.4	0.1									
	11T302L-U	9.525	3.97	4.4	0.2									
	11T304L-U	9.525	3.97	4.4	0.4									
	070202R-W10	6.35	2.38	2.8	0.2									
	070204R-W10	6.35	2.38	2.8	0.4									
	11T302R-W15	9.525	3.97	4.4	0.2									
	11T304R-W15	9.525	3.97	4.4	0.4									
	070202L-W10	6.35	2.38	2.8	0.2									
	070204L-W10	6.35	2.38	2.8	0.4									
	11T302L-W15	9.525	3.97	4.4	0.2									
	11T304L-W15	9.525	3.97	4.4	0.4									
	11T304-GF	9.525	3.97	4.4	0.4									
	11T302-YL	9.525	3.97	4.4	0.2									
	11T304-YL	9.525	3.97	4.4	0.4									

◆常备库存 ◇预定库存

DC□□

菱形有孔



DCGT 12 04 04 - □□

断屑槽代号
刀尖圆弧半径(r_ϵ)
厚度(S)
切削刃长度(ℓ)

A 车刀系列

B 铣刀系列

C 槽刀系列

D 螺纹刀片系列

刀片外形	型号	尺寸				通用			CVD			金属陶瓷		
		ϕD	S	ϕd	R	ZP50	ZP55	CP10	CP20	CP25	CK30	T20P	T10	T20
	070202-AK	6.35	2.38	2.9	0.2									
	070204-AK	6.35	2.38	2.9	0.4									
	070201-CK	6.35	2.38	2.8	0.1									
	11T302-AK	9.525	3.97	4.4	0.2									
	11T304-AK	9.525	3.97	4.4	0.4									
	11T308-AK	9.525	3.97	4.4	0.8									
	070204-UX	6.35	2	2.8	0.4									
	070202-AK	6.35	2.38	2.8	0.2									
	070204-AK	6.35	2.38	2.8	0.4									
	070208-AK	6.35	2.38	2.8	0.8									
	11T302-AK	9.525	3.97	4.4	0.2									
	11T304-AK	9.525	3.97	4.4	0.4									

◆常备库存 ◇预定库存

DC□□

菱形有孔

55° 正前角7°

DCMT 07 02 02 - □□

断屑槽代号
刀尖圆弧半径(r_ϵ)
厚度(S)
切削刃长度(l)

A 车刀系列

B 铣刀系列

C 槽刀系列

D 螺纹刀片系列

刀片外形	型号	尺寸				通用			CVD			金属陶瓷		
		ϕD	S	ϕd	R	ZP50	ZP55	CP10	CP20	CP25	CK30	T20P	T10	T20
	11T304-PM	9.525	3.97	4.4	0.4									
	11T308-PM	9.525	3.97	4.4	0.8									
	070204-FGT	6.35	2.38	2.8	0.4									
	11T304-FGT	9.525	3.97	4.4	0.4									
	070202	6.35	2.38	2.8	0.2									
	070204	6.35	2.38	2.8	0.4									
	070208	6.35	2.38	2.8	0.8									
	11T304	9.525	3.97	4.4	0.4									
	11T308	9.525	3.97	4.4	0.8									
	070202-MVS	6.35	2.38	2.8	0.2									
	070204-MVS	6.35	2.38	2.8	0.4									
	11T302-MVS	9.525	3.97	4.4	0.2									
	11T304-MVS	9.525	3.97	4.4	0.4									
	11T308-MVS	9.525	3.97	4.4	0.8									
	070202-HQJ	6.35	2.38	2.8	0.2									
	070204-HQJ	6.35	2.38	2.8	0.4									
	070208-HQJ	6.35	2.38	2.8	0.8									
	11T302-HQJ	9.525	3.97	4.4	0.2									
	11T304-HQJ	9.525	3.97	4.4	0.4									
	11T308-HQJ	9.525	3.97	4.4	0.8									

◆常备库存 ◇预定库存

DC□□

菱形有孔

55° 正前角7°

DCMT 07 02 02 - □□

断屑槽代号
刀尖圆弧半径(r_ϵ)
厚度(S)
切削刃长度(l)

A 车刀系列

B 铣刀系列

C 槽刀系列

D 螺纹刀片系列

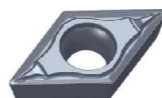
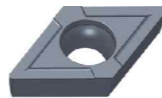
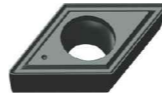
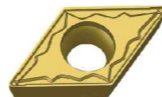
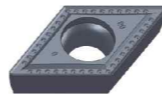
刀片外形	型号	尺寸				通用			CVD			金属陶瓷		
		ϕD	S	ϕd	R	ZP50	ZP55	CP10	CP20	CP25	CK30	T20P	T10	T20
	070202-PSD	6.35	2.38	2.8	0.2									
	070204-PSD	6.35	2.38	2.8	0.4									
	070208-PSD	6.35	2.38	2.8	0.8									
	110302-PSD	9.525	3.97	4.4	0.2									
	11T304-PSD	9.525	3.97	4.4	0.4									
	070204-24D	6.35	2.38	2.8	0.4									
	11T304-24D	9.525	3.97	4.4	0.4									
	11T304-NN	9.525	3.97	4.4	0.4									
	11T308-NN	9.525	3.97	4.4	0.8									
	070204-HMP	6.35	2.38	2.8	0.4									
	11T304-HMP	9.525	3.97	4.4	0.4									
	11T308-HMP	9.525	3.97	4.4	0.8									
	11T304-MT	9.525	3.97	4.4	0.4									
	11T308-MT	9.525	3.97	4.4	0.8									

◆常备库存 ◇预定库存

SC□□

正方形有孔



SCMT 12 04 04 - □□

断屑槽代号
刀尖圆弧半径(r_ϵ)
厚度(S)
切削刃长度(ℓ)

刀片外形	型号	尺寸				通用			CVD			金属陶瓷		
		ϕD	S	ϕd	R	ZP50	ZP55	CP10	CP20	CP25	CK30	T20P	T10	T20
	90T304-HQJ	9.525	3.97	4.4	0.4									
	90T308-HQJ	9.525	3.97	4.4	0.8									
	09T304	9.525	3.97	4.4	0.4									
	09T308	9.525	3.97	4.4	0.8									
	120404	12.7	4.76	5.5	0.4									
	120408	12.7	4.76	5.5	0.8									
	09T304-PSD	9.525	3.97	4.4	0.4									
	09T308-PSD	9.525	3.97	4.4	0.8									
	09T304-24D	9.525	3.97	4.4	0.4									
	09T308-24D	9.525	3.97	4.4	0.8									
	09T304-HMP	9.525	3.97	4.4	0.4									
	09T308-HMP	9.525	3.97	4.4	0.8									

◆常备库存 ◇预定库存

SN□□

正方形有孔



SNMG 12 04 04 - □□

断屑槽代号
刀尖圆弧半径(r_ϵ)
厚度(S)
切削刃长度(ℓ)

刀片外形	型号	尺寸				通用			CVD			金属陶瓷		
		ϕD	S	ϕd	R	ZP50	ZP55	CP10	CP20	CP25	CK30	T20P	T10	T20
	120404-MAS	12.7	4.76	5.16	0.4									
	120408-MAS	12.7	4.76	5.16	0.8									
	150408-MAS	15.875	4.76	6.35	0.8									
	150608-MAS	15.875	6.35	6.35	0.8									
	150612-MAS	15.875	6.35	6.35	1.2									
	120404-MSS	12.7	4.76	5.16	0.4									
	120408-MSS	12.7	4.76	5.16	0.8									
	120412-MSS	12.7	4.76	5.16	1.2									
	120404-HQJ	12.7	4.76	5.16	0.4									
	120408-HQJ	12.7	4.76	5.16	0.8									
	120404-TMD	12.7	4.76	5.16	0.4									
	120408-TMD	12.7	4.76	5.16	0.8									
	120404-HSK	12.7	4.76	5.16	0.4									
	120408-HSK	12.7	4.76	5.16	0.8									
	120404-HAK	12.7	4.76	5.16	0.4									
	120408-HAK	12.7	4.76	5.16	0.8									
	120404-HMK	12.7	4.76	5.16	0.4									
	120408-HMK	12.7	4.76	5.16	0.8									
	120404	12.7	4.76	-	0.4									
	150404	15.875	4.76	-	0.4									

◆常备库存 ◇预定库存

CN□□

菱形有孔



CNMG 12 04 04 - □□

断屑槽代号
刀尖圆弧半径(r_ϵ)
厚度(S)
切削刃长度(ℓ)

A 车刀系列

B 铣刀系列

C 槽刀系列

D 螺纹刀片系列

刀片外形	型号	尺寸				通用			CVD			金属陶瓷		
		ϕD	S	ϕd	R	ZP50	ZP55	CP10	CP20	CP25	CK30	T20P	T10	T20
	120404-MAS	12.7	4.76	5.16	0.4									
	120408-MAS	12.7	4.76	5.16	0.8									
	120412-MAS	12.7	4.76	5.16	1.2									
	090304-MSS	9.525	3.18	3.81	0.4									
	090308-MSS	9.525	3.18	3.81	0.8									
	120404-MSS	12.7	4.76	5.16	0.4									
	120404-MSS	12.7	4.76	5.16	0.8									
	120412-MSS	12.7	4.76	5.16	1.2									
	120404-HQJ	12.7	4.76	5.16	0.4									
	120408-HQJ	12.7	4.76	5.16	0.8									
	120412-HQJ	12.7	4.76	5.16	1.2									
	120404-TSD	12.7	4.76	5.16	0.4									
	120408-TSD	12.7	4.76	5.16	0.8									
	120404-TMD	12.7	4.76	5.16	0.4									
	120408-TMD	12.7	4.76	5.16	0.8									
	120412-TMD	12.7	4.76	5.16	1.2									

◆ 常备库存 ◇ 预定库存

CN□□

菱形有孔



CNMG 12 04 04 - □□

断屑槽代号
刀尖圆弧半径(r_ϵ)
厚度(S)
切削刃长度(ℓ)

A 车刀系列

B 铣刀系列

C 槽刀系列

D 螺纹刀片系列

刀片外形	型号	尺寸				通用			CVD			金属陶瓷		
		ϕD	S	ϕd	R	ZP50	ZP55	CP10	CP20	CP25	CK30	T20P	T10	T20
	120404-HAK	12.7	4.76	5.16	0.4									
	120408-HAK	12.7	4.76	5.16	0.8									
	120404-HSK	12.7	4.76	5.16	0.4									
	120408-HSK	12.7	4.76	5.16	0.8									
	120404-HMK	12.7	4.76	5.16	0.4									
	120408-HMK	12.7	4.76	5.16	0.8									
	120404-GSK	12.7	4.76	5.16	0.4									
	120408-GSK	12.7	4.76	5.16	0.8									
	120404-PM	12.7	4.76	5.16	0.4									
	120408-PM	12.7	4.76	5.16	0.8									
	120404-LN	12.7	4.76	5.16	0.4									
	120408-LN	12.7	4.76	5.16	0.8									

◆ 常备库存 ◇ 预定库存

WN□□

六角形有孔

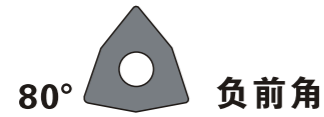

WNMG 08 04 04 - □□

断屑槽代号
刀尖圆弧半径(r_ϵ)
厚度(S)
切削刃长度(l)

A 车刀系列

B 铣刀系列

C 槽刀系列

D 螺纹刀片系列

刀片外形	型号	尺寸				通用			CVD			金属陶瓷		
		ϕD	S	ϕd	R	ZP50	ZP55	CP10	CP20	CP25	CK30	T20P	T10	T20
	06T312-MAS	9.525	3.97	3.18	1.2									
	080404-MAS	12.7	4.76	5.16	0.4									
	080408-MAS	12.7	4.76	5.16	0.8									
	080412-MAS	12.7	4.76	5.16	1.2									
	100608-MAS	15.875	6.35	6.35	0.8									
	100612-MAS	15.875	6.35	6.35	1.2									
	080404-MSS	9.525	4.76	5.16	0.4									
	080408-MSS	9.525	4.76	5.16	0.8									
	080412-MSS	9.525	4.76	5.16	1.2									
	080404-HQJ	12.7	4.76	5.16	0.4									
	080408-HQJ	12.7	4.76	5.16	0.8									
	080412-HQJ	12.7	4.76	5.16	1.2									
	080404-TSD	12.7	4.76	5.16	0.4									
	080408-TSD	12.7	4.76	5.16	0.4									
	080404-TMD	12.7	4.76	5.16	0.4									
	080408-TMD	12.7	4.76	5.16	0.8									
	080412-TMD	12.7	4.76	5.16	1.2									
	080404R/L-C	12.7	4.76	5.16	0.4									
	080408R/L-C	12.7	4.76	5.16	0.8									

◆常备库存 ◇预定库存

WN□□

六角形有孔



WNMG 08 04 04 - □□

断屑槽代号
刀尖圆弧半径(r_ϵ)
厚度(S)
切削刃长度(l)

A 车刀系列

B 铣刀系列

C 槽刀系列

D 螺纹刀片系列

刀片外形	型号	尺寸				通用			CVD			金属陶瓷		
		ϕD	S	ϕd	R	ZP50	ZP55	CP10	CP20	CP25	CK30	T20P	T10	T20
	080404-HA	12.7	4.76	5.16	0.4									
	080408-HA	12.7	4.76	5.16	0.8									
	080404-HS	12.7	4.76	5.16	0.4									
	080408-HS	12.7	4.76	5.16	0.8									
	080404-GS	12.7	4.76	5.16	0.4									
	080408-GS	12.7	4.76	5.16	0.8									
	080404-HM	12.7	4.76	5.16	0.4									
	080404-MTT	12.7	4.76	5.16	0.4									
	080408-MTT	12.7	4.76	5.16	0.8									
	080404-PM	12.7	4.76	5.16	0.4									
	080408-PM	12.7	4.76	5.16	0.8									

◆常备库存 ◇预定库存

VB□□

菱形有孔

35° 正前角5°

VBGT 11 03 02 - □□

断屑槽代号
刀尖圆弧半径(r_ϵ)
厚度(S)
切削刃长度(l)

A 车刀系列

B 铣刀系列

C 槽刀系列

D 螺纹刀片系列

刀片外形	型号	尺寸				通用		CVD					金属陶瓷		
		ϕD	S	ϕd	R	ZP50	ZP55	CP10	CP20	CP25	CK30	T20P	T10	T20	
	VBGT 110302R-Y	6.35	3.18	2.8	0.2										
	110304R-Y	6.35	3.18	2.8	0.4										
	110302L-Y	6.35	3.18	2.8	0.2										
	110304L-Y	6.35	3.18	2.8	0.4										
	160402R-Y	9.525	4.75	4.4	0.2										
	160404R-Y	9.525	4.75	4.4	0.4										
	160402L-Y	9.525	4.75	4.4	0.2										
	160404L-Y	9.525	4.75	4.4	0.4										
	VBGT 110302R-F	6.35	3.18	2.8	0.2										
	110304R-F	6.35	3.18	2.8	0.4										
	110302L-F	6.35	3.18	2.8	0.2										
	110304L-F	6.35	3.18	2.8	0.4										
	VBGT 110301FR-J10	6.35	3.18	2.8	0.1										
	110302FR-J10	6.35	3.18	2.8	0.2										
	110304FR-J10	6.35	3.18	2.8	0.4										
	110301FL-J10	6.35	3.18	2.8	0.1										
	110302FL-J10	6.35	3.18	2.8	0.2										
	110304FL-J10	6.35	3.18	2.8	0.4										
	VBGT 110301-GF	6.35	3.18	2.8	0.1										
	110302-GF	6.35	3.18	2.8	0.2										
	110304-GF	6.35	3.18	2.8	0.4										
	VBGT 110302-YL	6.35	3.18	2.8	0.2										
	110304-YL	6.35	3.18	2.8	0.4										
	VBGT 110302-AK	6.35	3.18	2.8	0.2										
	110304-AK	6.35	3.18	2.8	0.4										
	160402-AK	9.525	4.75	4.4	0.2										
	160404-AK	9.525	4.76	4.4	0.4										

◆常备库存 ◇预定库存

VB□□

菱形有孔

35° 正前角5°

VBMT 11 03 02 - □□

断屑槽代号
刀尖圆弧半径(r_ϵ)
厚度(S)
切削刃长度(l)

A 车刀系列

B 铣刀系列

C 槽刀系列

D 螺纹刀片系列

刀片外形	型号	尺寸				通用		CVD					金属陶瓷		
		ϕD	S	ϕd	R	ZP50	ZP55	CP10	CP20	CP25	CK30	T20P	T10	T20	
	VBMT 160404	9.525	4.76	4.4	0.4										
	160408	9.525	4.76	4.4	0.8										
	VBMT 110304-MVS	6.35	3.18	2.8	0.4										
	110308-MVS	6.35	3.18	2.8	0.8										
	160404-MVS	9.525	4.76	4.4	0.4										
	160408-MVS	9.525	4.76	4.4	0.8										
	VBMT 110304-HQJ	6.35	3.18	2.8	0.4										
	110308-HQJ	6.35	3.18	2.8	0.8										
	160404-HQJ	9.525	4.76	4.4	0.4										
	160408-HQJ	9.525	4.76	4.4	0.8										
	110302-PSD	6.35	3.18	2.8	0.2										
	110304-PSD	6.35	3.18	2.8	0.4										
	160404-PSD	9.525	4.76	4.4	0.4										
	160408-PSD	9.525	4.76	4.4	0.8										
	160404-HMP	9.525	4.76	4.4	0.4										
	160408-HMP	9.525	4.76	4.4	0.8										
	160404-PM	9.525	4.76	4.4	0.4										
	160408-PM	9.525	4.76	4.4	0.8										

◆常备库存 ◇预定库存

VN□□

菱形有孔

35° 负前角

VNMG 16 04 04 - □□



断屑槽代号
刀尖圆弧半径(r_ϵ)
厚度(S)
切削刃长度(l)

A 车刀系列

B 铣刀系列

C 槽刀系列

D 螺纹刀片系列

刀片外形	型号	尺寸				通用		CVD					金属陶瓷		
		ϕD	S	ϕd	R	ZP50	ZP55	CP10	CP20	CP25	CK30	T20P	T10	T20	
 	160404-MAS	9.525	4.76	3.81	0.4										
	160408-MAS	9.525	4.76	3.81	0.8										
 	160404-MSS	9.525	4.76	3.81	0.4										
	160408-MSS	9.525	4.76	3.81	0.8										
 	160404-HQJ	9.525	4.76	3.81	0.4										
	160408-HQJ	9.525	4.76	3.81	0.8										
 	160404-TSD	9.525	4.76	3.81	0.4										
	160408-TSD	9.525	4.76	3.81	0.8										
 	160404-TMD	9.525	4.76	3.81	0.4										
	160408-TMD	9.525	4.76	3.81	0.8										
 	160404-PM	9.525	4.76	3.81	0.4										
	160408-PM	9.525	4.76	3.81	0.8										

◆常备库存 ◇预定库存

VC□□

菱形有孔

35° 正前角7°

VCGT 11 03 02 - □□

断屑槽代号
刀尖圆弧半径(r_ϵ)
厚度(S)
切削刃长度(l)

A 车刀系列

B 铣刀系列

C 槽刀系列

D 螺纹刀片系列

刀片外形	型号	尺寸				通用		CVD					金属陶瓷		
		ϕD	S	ϕd	R	ZP50	ZP55	CP10	CP20	CP25	CK30	T20P	T10	T20	
 	110302-AK	6.35	2.38	2.8	0.2										
	110304-AK	6.35	2.38	2.8	0.4										
	110308-AK	6.35	2.38	2.8	0.8										
	160402-AK	9.525	3.97	4.4	0.2										
	160404-AK	9.525	3.97	4.4	0.4										
 	110301-GF	6.35	3.18	2.8	0.1										
	110302-GF	6.35	3.18	2.8	0.2										
	110304-GF	6.35	3.18	2.8	0.4										
 	110302-YL	6.35	3.18	2.8	0.2										
	110304-YL	6.35	3.18	2.8	0.4										
 	110302-PSD	6.35	3.18	2.8	0.2										
	110304-PSD	6.35	3.18	2.8	0.4										
	160404-PSD	9.525	4.76	4.4	0.4										
 	110304-MSS	6.35	3.18	2.8	0.4										
	160404-MSS	9.525	4.76	4.4	0.4										

◆常备库存 ◇预定库存

WNMU□□

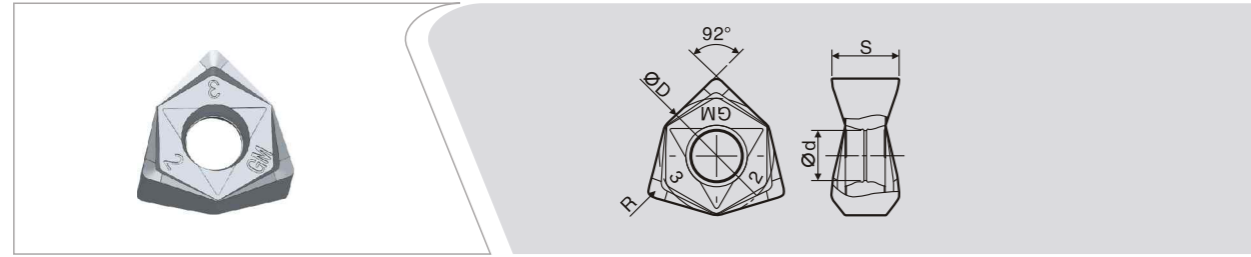

型号	尺寸				通用		CVD			金属陶瓷			
	φD	S	φd	R	ZP50	ZP55	CP10	CP20	CP25	CK30	T20P	T10	T20
WNMU 080608EN-GM	14.02	8.4	6.1	0.8									

◆常备库存 ◇预定库存

PNMU□□

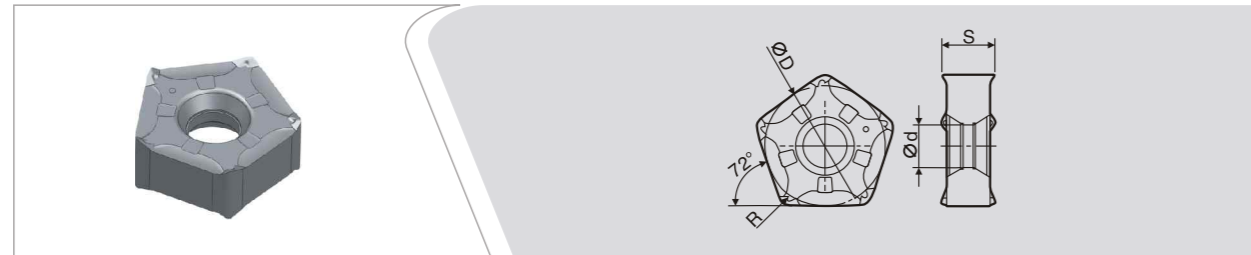

型号	尺寸				通用		CVD			金属陶瓷			
	φD	S	φd	R	ZP50	ZP55	CP10	CP20	CP25	CK30	T20P	T10	T20
PNMU 090508XNEN-GM	13.4	6.2	4.7	0.8									

◆常备库存 ◇预定库存

LNMU□□

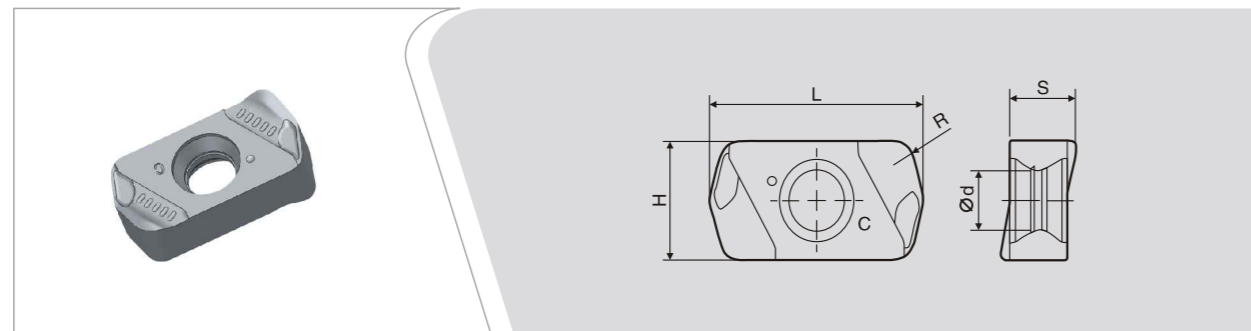

型号	尺寸				通用		CVD			金属陶瓷			
	L	H	φd	S	ZP50	ZP55	CP10	CP20	CP25	CK30	T20P	T10	T20
LNMU 030303	12	6	3.0	3.7									

◆常备库存 ◇预定库存

APMT□□

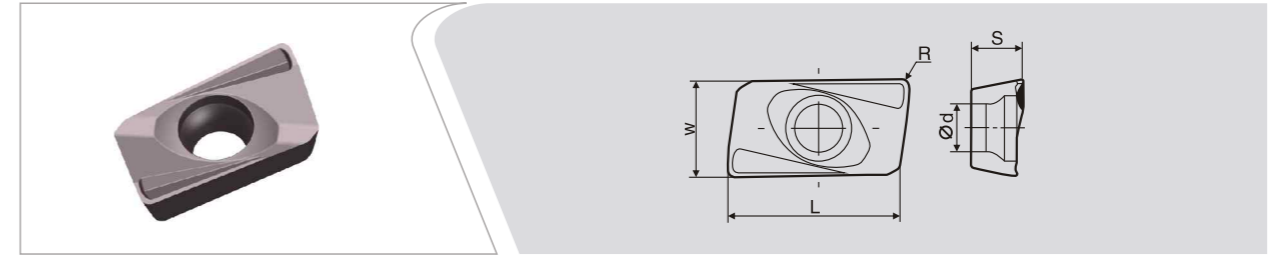

型号	尺寸				通用		CVD			金属陶瓷			
	L	W	S	φd	ZP50	ZP55	CP10	CP20	CP25	CK30	T20P	T10	T20
APMT 1135PDER-H2S	11	6.35	3.5	2.8									
1604PDER-H2S	16.5	9.525	4.76	4.4									

◆常备库存 ◇预定库存

APMT□□

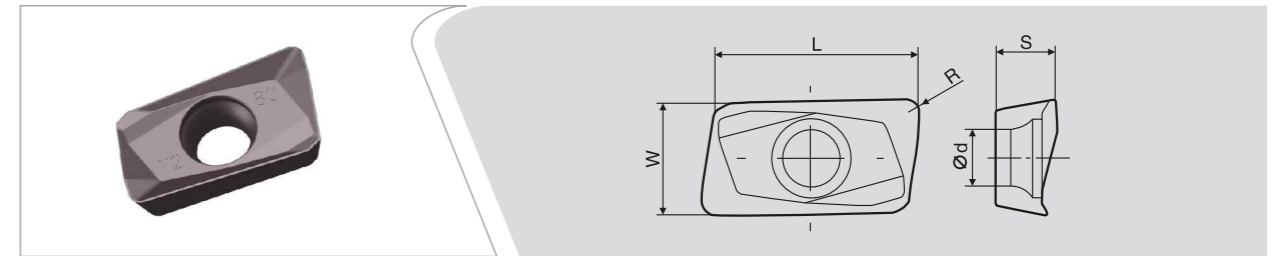

型号	尺寸				通用		CVD			金属陶瓷			
	L	W	S	φd	ZP50	ZP55	CP10	CP20	CP25	CK30	T20P	T10	T20
APMT 1135PDER-M2S	11	6.35	3.5	2.8									
1604PDER-M2S	16.5	9.525	4.76	4.4									

◆常备库存 ◇预定库存

APMT□□

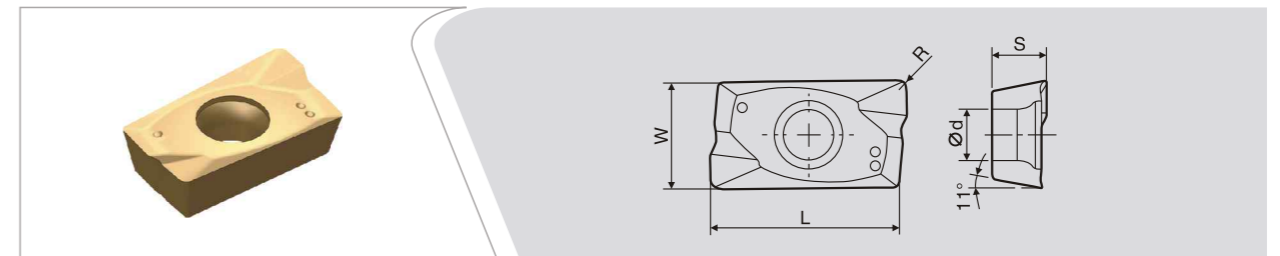

型号	尺寸				通用		CVD			金属陶瓷			
	L	W	S	φd	ZP50	ZP55	CP10	CP20	CP25	CK30	T20P	T10	T20
APMT 1135PDER-TT	11	6.2	3.65	2.8									
1604PDER-TT	16.4	9.35	5.4	4.4									

◆常备库存 ◇预定库存

A 车刀系列

B 铣刀系列

C 槽刀系列

D 螺纹刀片系列

A 车刀系列

B 铣刀系列

C 槽刀系列

D 螺纹刀片系列

RPMT□□

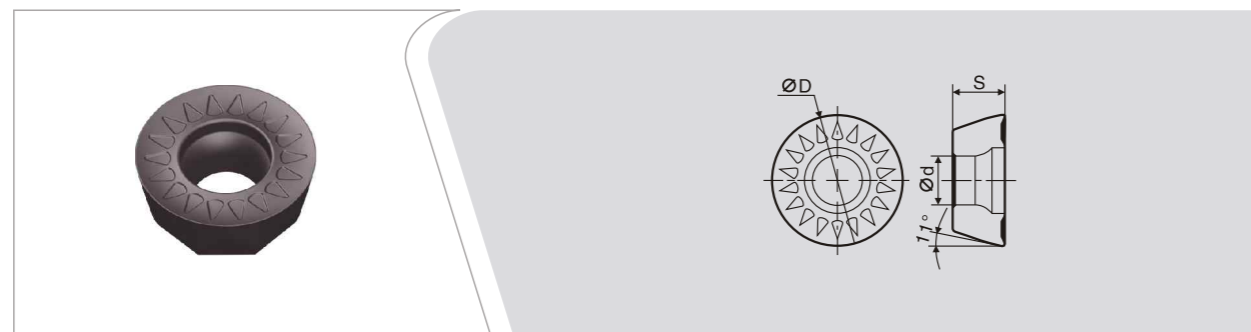

型号	尺寸			通用		CVD			金属陶瓷			
	ϕD	s	ϕd	ZP50	ZP55	CP10	CP20	CP25	CK30	T20P	T10	T20
RPMT	08T2MOE-JSS	8	2.78	2.8								
	10T3MOE-JSS	10	3.97	4.4								
	1204MOE-JSS	12	4.76	4.4								
	1606MOE-JSS	16	6.35	5.5								

◆常备库存 ◇预定库存

PRMW□□

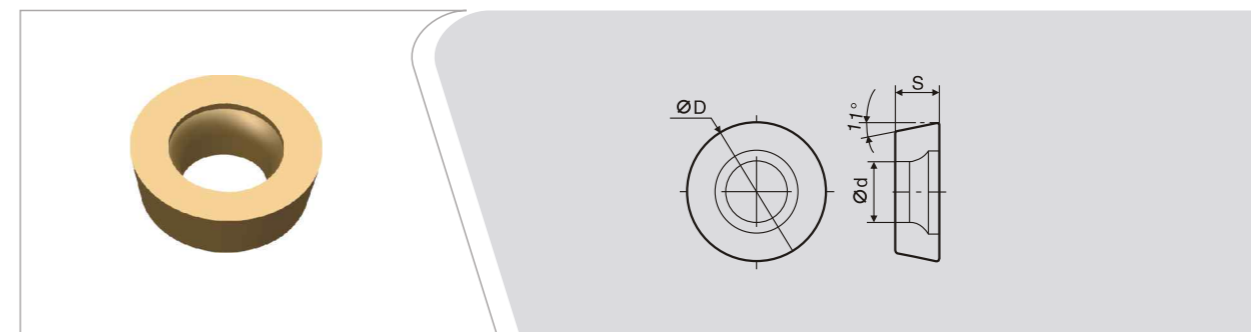

型号	尺寸			通用		CVD			金属陶瓷			
	ϕD	s	ϕd	ZP50	ZP55	CP10	CP20	CP25	CK30	T20P	T10	T20
PRMW	1003MO-TT	10	3.18	4.4								

◆常备库存 ◇预定库存

RPMW□□

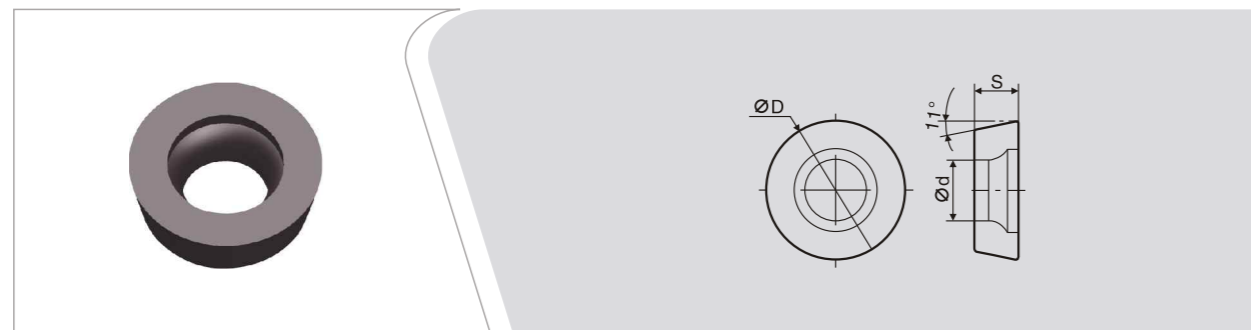

型号	尺寸			通用		CVD			金属陶瓷			
	ϕD	s	ϕd	ZP50	ZP55	CP10	CP20	CP25	CK30	T20P	T10	T20
RPMW	1003MO-S	10	3.18	4.4								

◆常备库存 ◇预定库存

RPMT□□

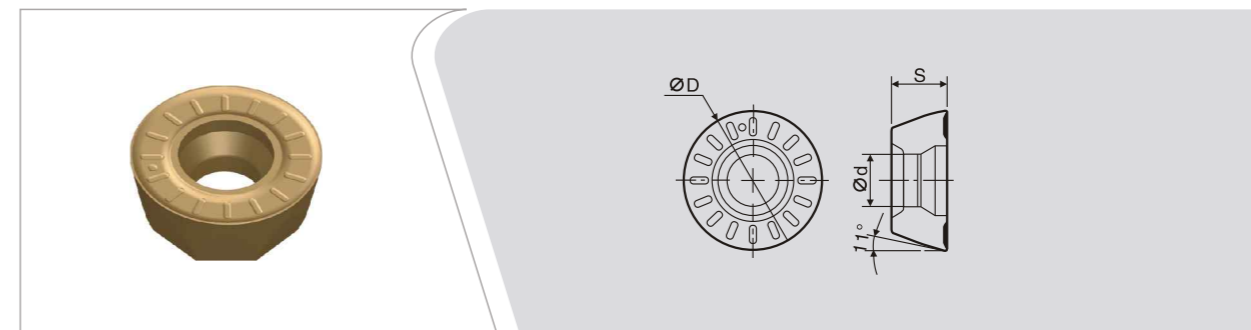

型号	尺寸			通用		CVD			金属陶瓷			
	ϕD	s	ϕd	ZP50	ZP55	CP10	CP20	CP25	CK30	T20P	T10	T20
RPMT	1204-M-C-TT	12	4.76	4.4								

◆常备库存 ◇预定库存

RPMT□□

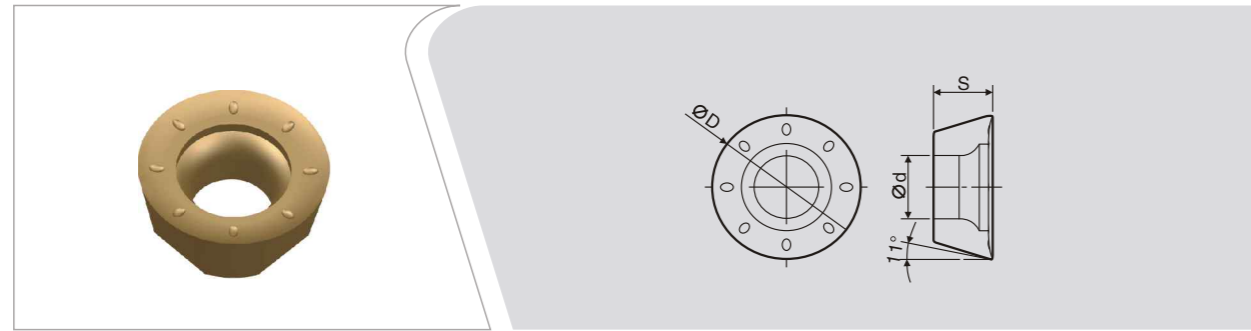

型号	尺寸			通用		CVD			金属陶瓷			
	φD	S	φd	ZP50	ZP55	CP10	CP20	CP25	CK30	T20P	T10	T20
RPMT 10T3MO-TT	10	3.97	4.3	◆		◇	◇	◇	◇	◇	◇	◇

◆常备库存 ◇预定库存

RCKT□□

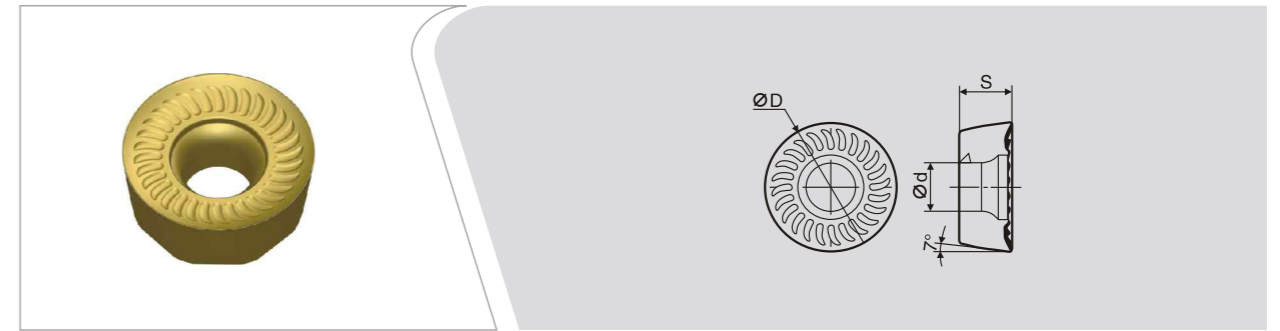

型号	尺寸			通用		CVD			金属陶瓷			
	φD	S	φd	ZP50	ZP55	CP10	CP20	CP25	CK30	T20P	T10	T20
RCKT 10T3MO-ST	10	3.97	4.4	◆		◇	◇	◇	◇	◇	◇	◇
1204MO-ST	12	4.76	4.4									
1606MO-ST	16	6.35	5.5									
2006MO-ST	20	6.35	6.5									

◆常备库存 ◇预定库存

RPKT□□

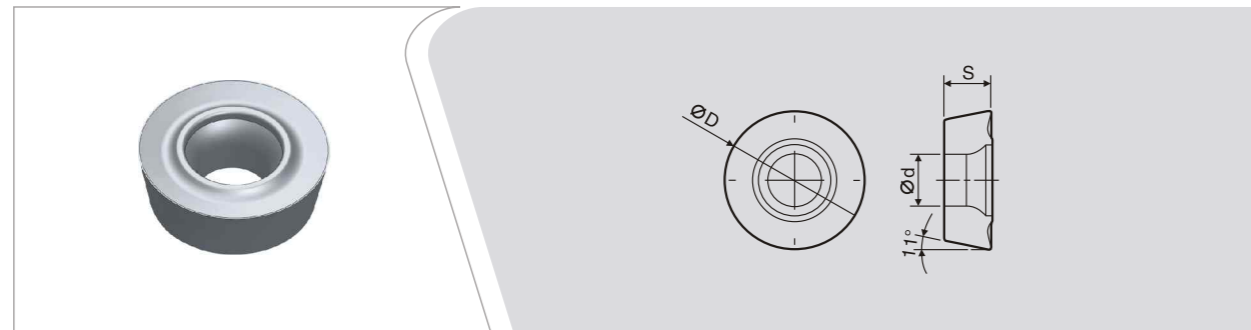

型号	尺寸			通用		CVD			金属陶瓷			
	φD	S	φd	ZP50	ZP55	CP10	CP20	CP25	CK30	T20P	T10	T20
RPKT 1203MO-BB	12	3.48	4.4	◆		◇	◇	◇	◇	◇	◇	◇
1604MO-BB	16	4.76	5.5									

◆常备库存 ◇预定库存

R390-□□

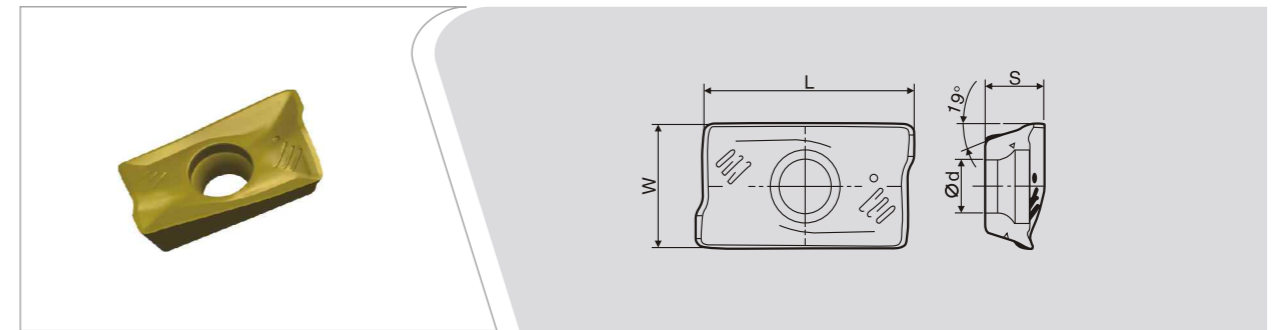

型号	尺寸				通用		CVD			金属陶瓷			
	L	S	φd	R	ZP50	ZP55	CP10	CP20	CP25	CK30	T20P	T10	T20
R390- 11T304 M-PM	11	3.5	2.8	0.4	◆		◇	◇	◇	◇	◇	◇	◇
11T308 M-PM	11	3.5	2.8	0.8									
170408 M-PM	17	4.7	4.4	0.8									
180608 M-PM	15.8	6.3	4.5	0.8									

◆常备库存 ◇预定库存

SEKR□□

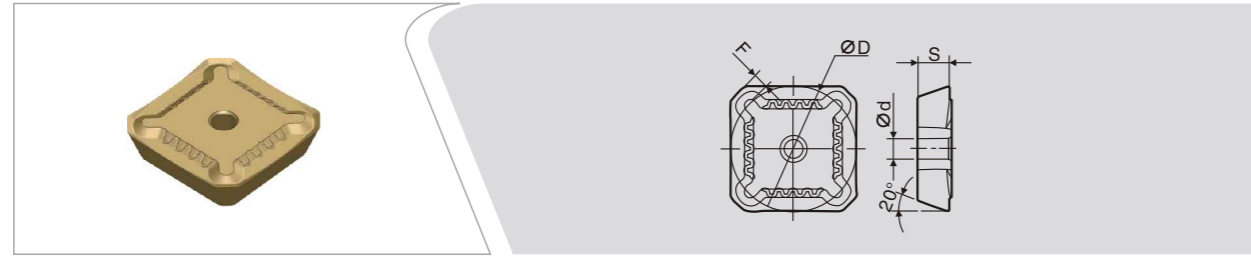

型号	尺寸				通用							CVD			金属陶瓷								
	ϕD	S	ϕd	F	ZP50	ZP55	CP10	CP20	CP25	CK30	T20P	T10	T20	ZP50	ZP55	CP10	CP20	CP25	CK30	T20P	T10	T20	
SEKR 1203AZ-YMZ	12.5	3.18	2	1.5	■									■									

◆常备库存 ◇预定库存

JDMW□□

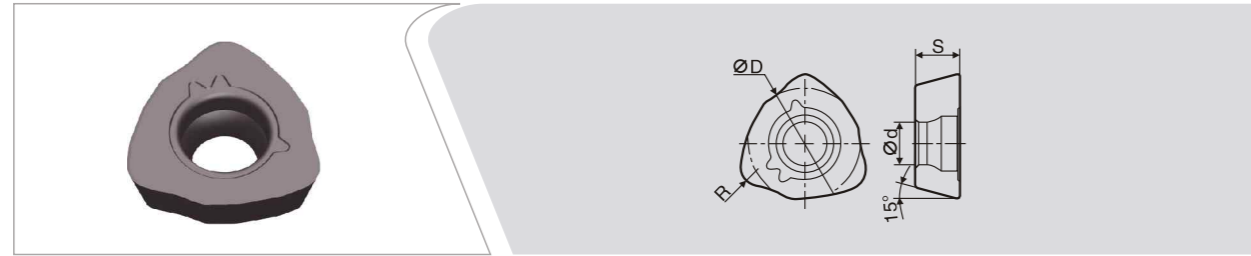

型号	尺寸				通用							CVD			金属陶瓷								
	S	ϕd	R	ϕD	ZP50	ZP55	CP10	CP20	CP25	CK30	T20P	T10	T20	ZP50	ZP55	CP10	CP20	CP25	CK30	T20P	T10	T20	
JDMW 120420ZDSR-FTS	4.76	4.6	2	12	■									■									

◆常备库存 ◇预定库存

SEMT□□



型号	尺寸				通用							CVD			金属陶瓷								
	ϕD	S	ϕd	F	ZP50	ZP55	CP10	CP20	CP25	CK30	T20P	T10	T20	ZP50	ZP55	CP10	CP20	CP25	CK30	T20P	T10	T20	
SEMT 13T3AGSN-JMS	13.4	3.97	4.4	2.2	■									■									

◆常备库存 ◇预定库存

SNMX□□

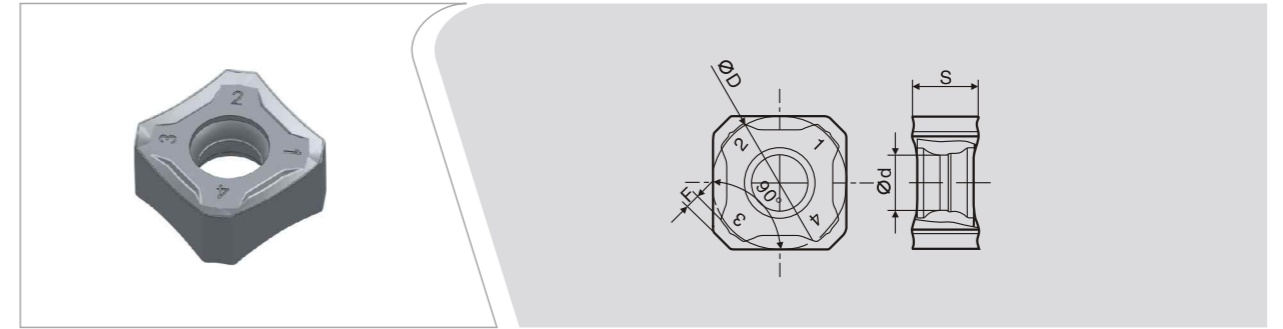

型号	尺寸				通用							CVD			金属陶瓷								
	ϕD	S	ϕd	F	ZP50	ZP55	CP10	CP20	CP25	CK30	T20P	T10	T20	ZP50	ZP55	CP10	CP20	CP25	CK30	T20P	T10	T20	
SNMX 1206ANN-MM	12.7	6.25	4.6	1.43	■									■									

◆常备库存 ◇预定库存

P3200□□

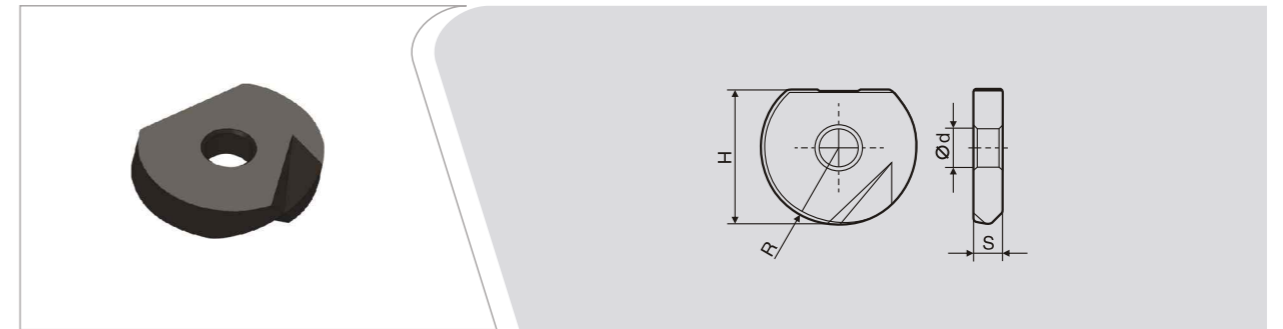

型号	尺寸				通用							CVD			金属陶瓷								
	H	R	S	ϕd	ZP50	ZP55	CP10	CP20	CP25	CK30	T20P	T10	T20	ZP50	ZP55	CP10	CP20	CP25	CK30	T20P	T10	T20	
P3200 08025	9.5	4	2	3	■									■									
10030	11.5	5	2.5	4																			
12030	11.8	6	2.5	5																			
16035	14	8	3	5																			
20040	16	10	3	5																			
25040	21.5	12.5	4	6																			

◆常备库存 ◇预定库存

A 车刀系列

B 铣刀系列

C 槽刀系列

D 螺纹刀片系列

A 车刀系列

B 铣刀系列

C 槽刀系列

D 螺纹刀片系列

BNM□□

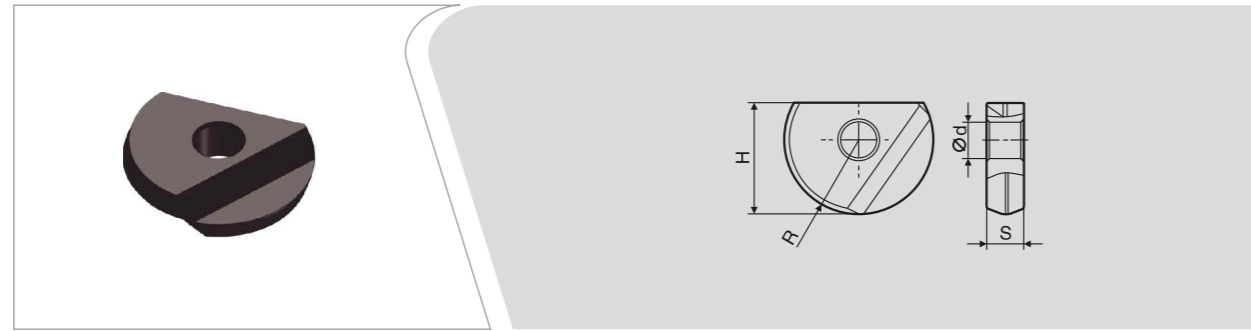

型号	尺寸				通用		CVD			金属陶瓷			
	H	R	S	φd	ZP50	ZP55	CP10	CP20	CP25	CK30	T20P	T10	T20
BNM													
160-DJ	12	8	4	4									
200-DJ	15	10	5	5									
250-DJ	18.5	12.5	6	6									
300-DJ	22.5	15	7	8									

◆常备库存 ◇预定库存

WCMX□□

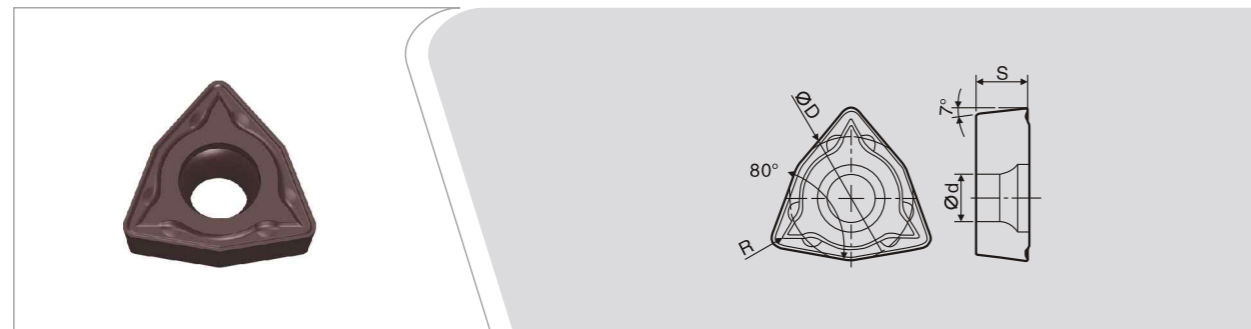

型号	尺寸				通用		CVD			金属陶瓷			
	φD	S	φd	R	ZP50	ZP55	CP10	CP20	CP25	CK30	T20P	T10	T20
WCMX													
030208-ZY	5.56	2.38	2.8	0.8									
040208-ZY	6.35	2.38	3.0	0.8									
050308-ZY	7.94	3.18	3.4	0.8									
06T308-ZY	9.525	3.97	3.8	0.8									
080412-ZY	12.7	4.76	4.4	1.2									

◆常备库存 ◇预定库存

SPMT□□

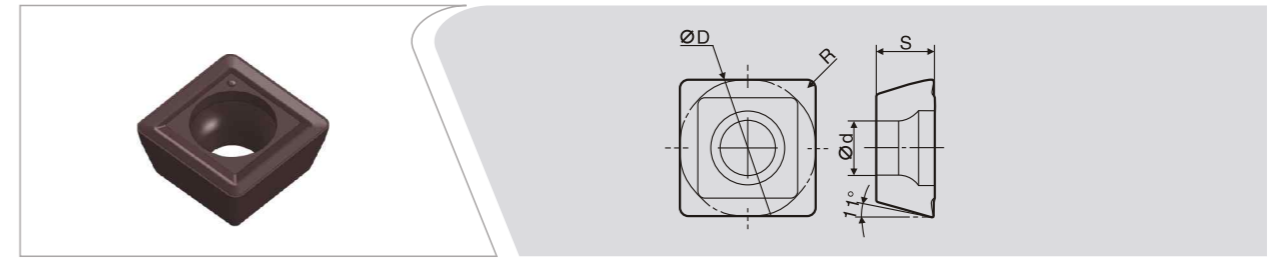

型号	尺寸				通用		CVD			金属陶瓷			
	φD	S	φd	R	ZP50	ZP55	CP10	CP20	CP25	CK30	T20P	T10	T20
SPMT													
050204-GD	5	2.38	2.3	0.4									
060204-GD	6	2.38	2.7	0.4									
07T308-GD	7.94	3.97	2.9	0.8									
090408-GD	9.8	4.3	4.1	0.8									
110408-GD	14.3	5.2	5.7	1.2									
140512-GD	11.5	4.8	4.5	0.8									

◆常备库存 ◇预定库存

880-□□

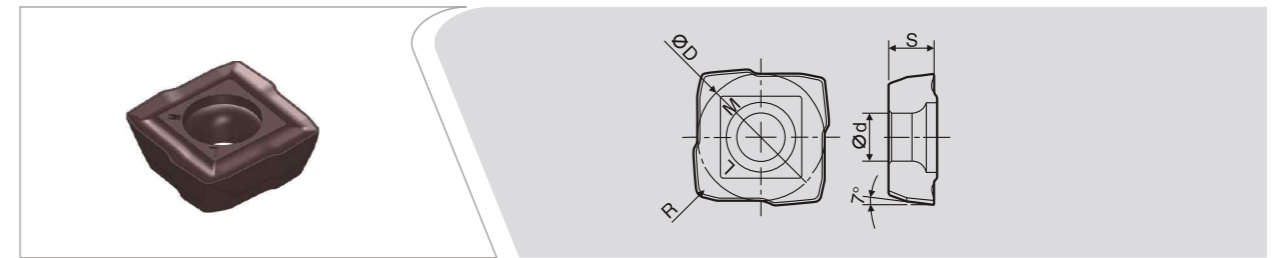

型号	尺寸				通用		CVD			金属陶瓷			
	φD	S	φd	R	ZP50	ZP55	CP10	CP20	CP25	CK30	T20P	T10	T20
880-													
040305H-C-LM	6.8	2.8	2.5	0.5									
050305H-C-LM	8.4	3	3.2	0.5									

◆常备库存 ◇预定库存

880-□□

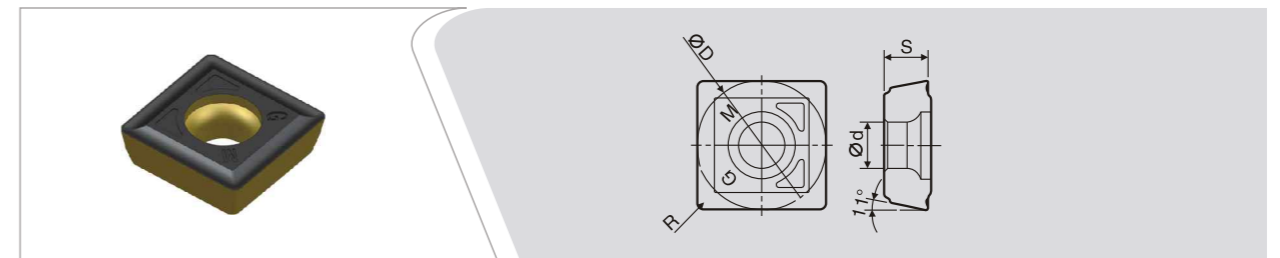

型号	尺寸				通用		CVD			金属陶瓷			
	φD	S	φd	R	ZP50	ZP55	CP10	CP20	CP25	CK30	T20P	T10	T20
880-													
0403W05H-P-GM	7.4	2.8	2.8	0.5									
0503W05H-P-GM	8.9	3	3.2	0.5									

◆常备库存 ◇预定库存

LNMT

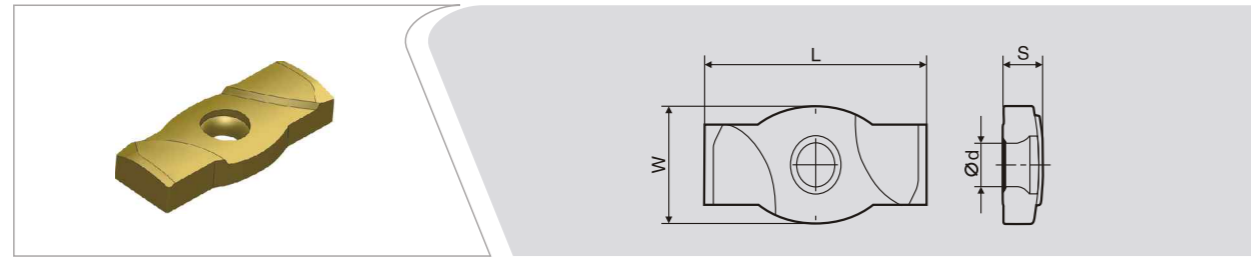

型号	尺寸				通用			CVD			金属陶瓷		
	φD	w	s	φd	ZP50	ZP55	CP10	CP20	CP25	CK30	T20P	T10	T20
LNMT 1803-RH	18	7.7	3.5	2.8									
2003-RH	20	9.2	3.5	3.5									
2504-RH	25	11.3	4.5	4.2									
3004-RH	30	13.3	4.5	4.2									
3506-RH	35	15.3	5.5	4.2									

◆常备库存 ◇预定库存

A 车刀系列

B 铣刀系列

C 槽刀系列

D 螺纹刀片系列

HXMX

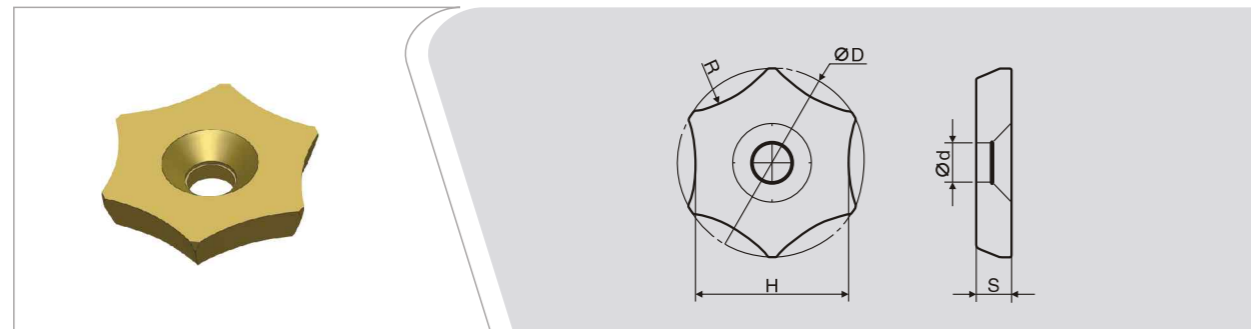

型号	尺寸				通用			CVD			金属陶瓷		
	φD	S	φd	R	ZP50	ZP55	CP10	CP20	CP25	CK30	T20P	T10	T20
HXMX 2504-R14	25.1	4.76	5.2	14.2									
2504-R17	25.1	4.76	5.2	17.3									
2504-R22	25.1	4.76	5.2	22.5									
2504-R29	25.1	4.76	5.2	29.4									
2504-R40	25.1	4.76	5.2	40.5									
2504-R50	25.1	4.76	5.2	50.9									

◆常备库存 ◇预定库存

SPUB

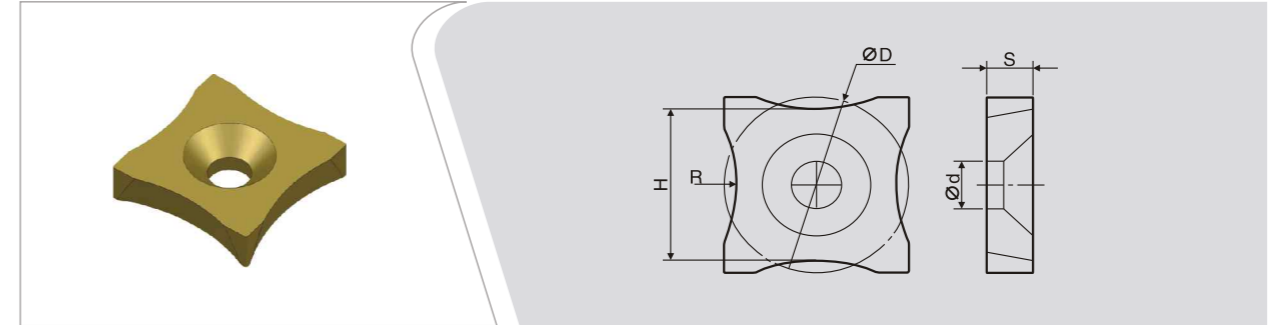

型号	尺寸				通用			CVD			金属陶瓷		
	φD	S	φd	R	ZP50	ZP55	CP10	CP20	CP25	CK30	T20P	T10	T20
SPUB 63A-R9	19	4.76	5.2	9.3									
63B-R12	19	4.76	5.2	12.4									
63C-R15	19	4.76	5.2	15.2									
63D-R20	19	4.76	5.2	20.2									
63E-R25	19	4.76	5.2	25.2									
63F-R30	19	4.76	5.2	30.2									

◆常备库存 ◇预定库存

A 车刀系列

B 铣刀系列

C 槽刀系列

D 螺纹刀片系列

SNMN

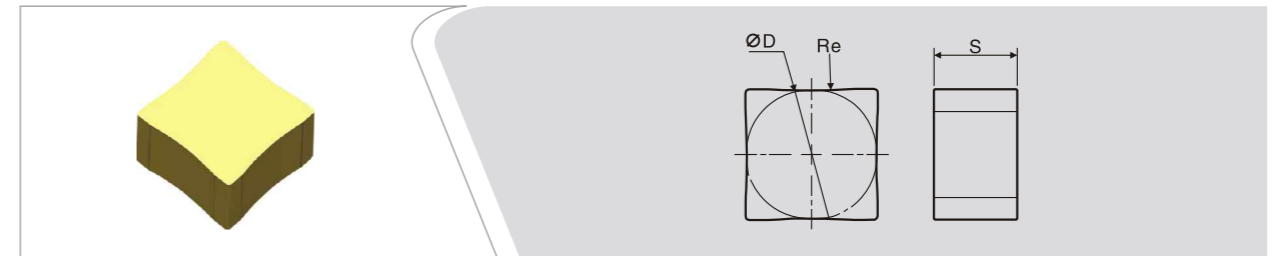

型号	尺寸			通用			CVD			金属陶瓷		
	φD	S	R	ZP50	ZP55	CP10	CP20	CP25	CK30	T20P	T10	T20
SNMN 12-R20	12.7	7.94	20									
12-R25	12.7	7.94	25									
12-R30	12.7	7.94	30									
12-R40	12.7	7.94	40									
12-R50	12.7	7.94	50									

◆常备库存 ◇预定库存

SDMW

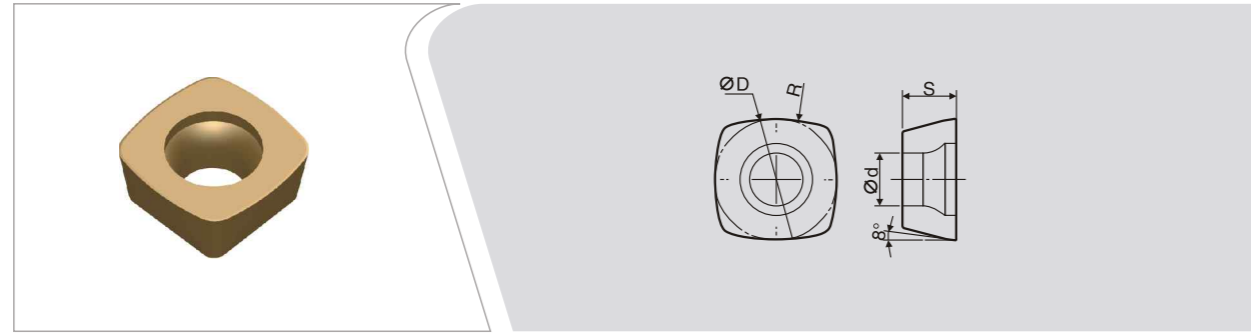

型号	尺寸				通用		CVD			金属陶瓷			
	ϕD	S	ϕd	R	ZP50	ZP55	CP10	CP20	CP25	CK30	T20P	T10	T20
SDMW 12-R20	12.7	5.56	5.5	19									
09-R12	9.525	3.97	3.8	19									
07-R08	7.94	3.18	3.3	19									

◆常备库存 ◇预定库存

LGD

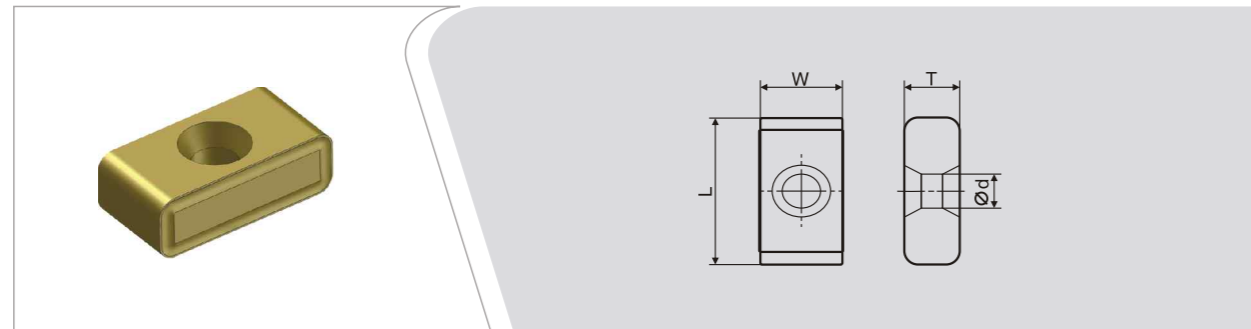

型号	尺寸				通用		CVD			金属陶瓷			
	L	W	T	ϕd	ZP50	ZP55	CP10	CP20	CP25	CK30	T20P	T10	T20
LGD 120904	12.7	9.525	4.76	4.4									
150904	15.875	9.525	4.76	4.4									
1906-12	19.05	9.525	6.35	4.4									

◆常备库存 ◇预定库存

LGD

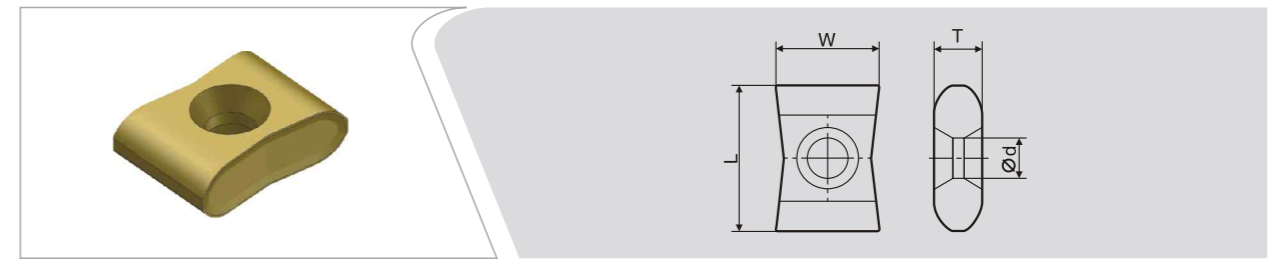

型号	尺寸				通用		CVD			金属陶瓷			
	L	W	T	ϕd	ZP50	ZP55	CP10	CP20	CP25	CK30	T20P	T10	T20
LGD 1206-R5	12.7	11.7	6.35	4.4									
151105-CMDC	15.9	11.3	5.2	4.4									

◆常备库存 ◇预定库存

LGD

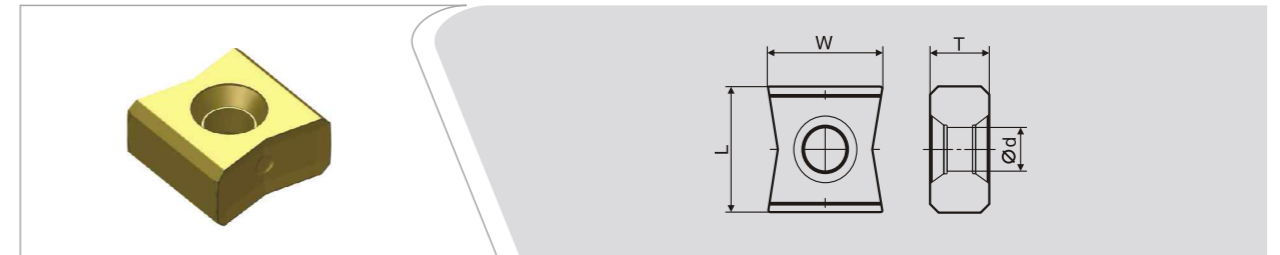

型号	尺寸				通用		CVD			金属陶瓷			
	L	W	T	ϕd	ZP50	ZP55	CP10	CP20	CP25	CK30	T20P	T10	T20
LGD 1206CMDC-JJL	12.7	12.3	6.35	4.4									
1506PN-TN	15	14	6	4.4									
1506-CX	15	13.8	6	4.4									

◆常备库存 ◇预定库存

CNGT

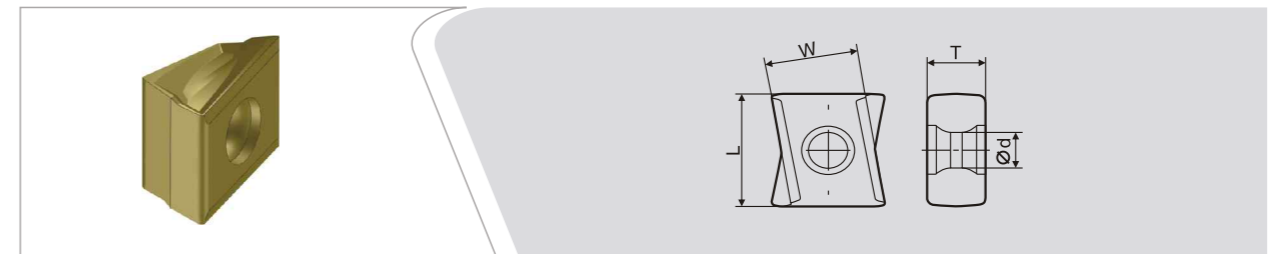

型号	尺寸				通用		CVD			金属陶瓷			
	L	W	T	ϕd	ZP50	ZP55	CP10	CP20	CP25	CK30	T20P	T10	T20
CNGT 1306CMDC-R	13.8	10.6	6.6	4.4									
1306CMDC-L	13.8	10.6	6.6	4.4									

◆常备库存 ◇预定库存

A 车刀系列

B 铣刀系列

C 槽刀系列

D 螺纹刀片系列

A 车刀系列

B 铣刀系列

C 槽刀系列

D 螺纹刀片系列

HD□□

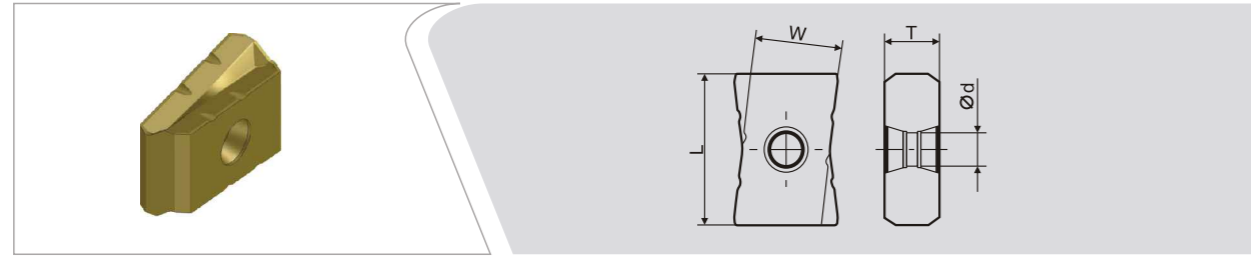

型号	尺寸				通用		CVD			金属陶瓷			
	L	W	T	φd	ZP50	ZP55	CP10	CP20	CP25	CK30	T20P	T10	T20
HD 2509CMDC	25	15	9.525	5.5									

◆常备库存 ◇预定库存

LSE□□

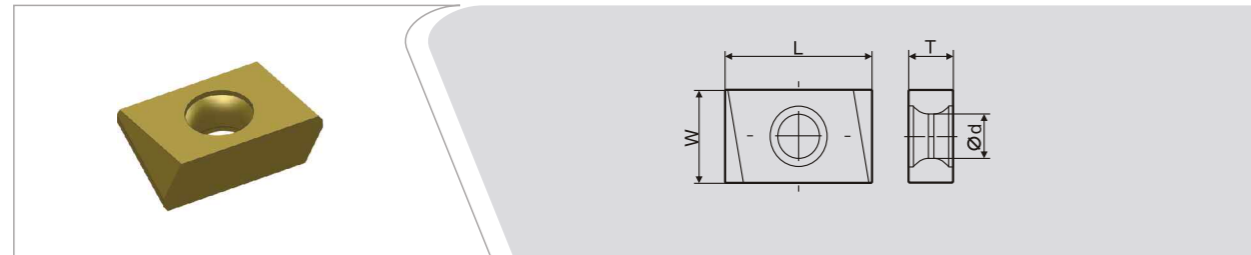

型号	尺寸				通用		CVD			金属陶瓷			
	L	W	T	φd	ZP50	ZP55	CP10	CP20	CP25	CK30	T20P	T10	T20
LSE 323R02/L02	15.9	9.5	4.8	4.4									
323R01/L01	19	14.3	6.35	5.5									
446R01/L01	28.6	14.3	9.5	5.5									

◆常备库存 ◇预定库存

L*E□□

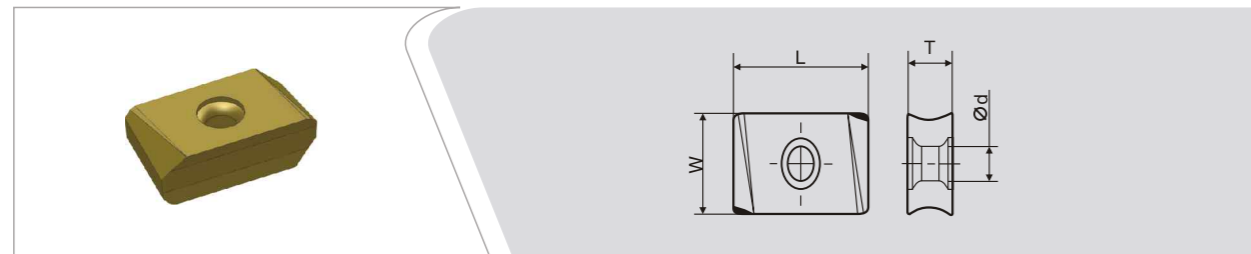

型号	尺寸				通用		CVD			金属陶瓷			
	L	W	T	φd	ZP50	ZP55	CP10	CP20	CP25	CK30	T20P	T10	T20
LSE 346R01-M	24	14.3	9.5	5.5									
LPE 435R100	19	14.3	8.5	5.5									
446R100	28.6	16.9	9.5	5.5									

◆常备库存 ◇预定库存

SNC□□

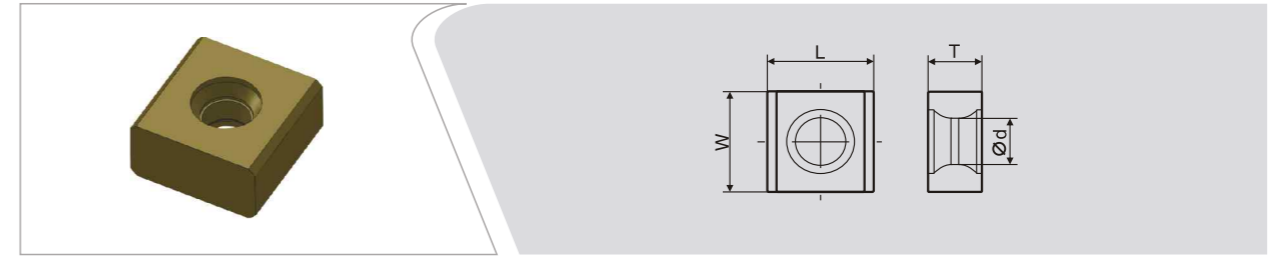

型号	尺寸				通用		CVD			金属陶瓷			
	L	W	T	φd	ZP50	ZP55	CP10	CP20	CP25	CK30	T20P	T10	T20
SNC 33	9.525	9.525	4.76	4.4									
44	12.7	12.7	6.35	5.5									
55	15.875	15.875	7.94	5.5									

◆常备库存 ◇预定库存

SPE□□

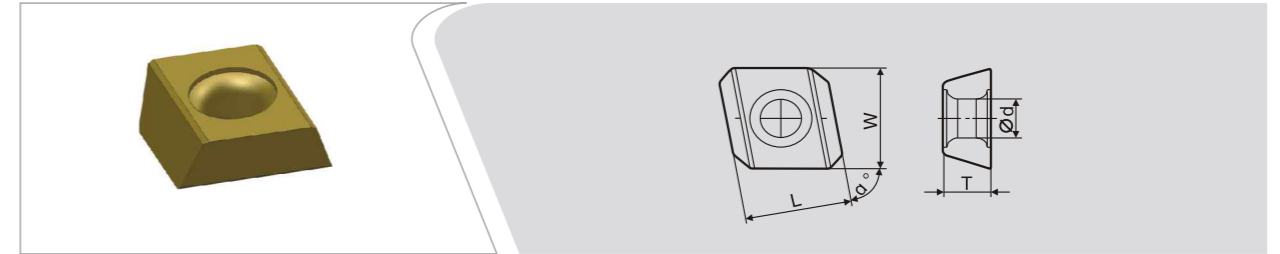

型号	尺寸				通用		CVD			金属陶瓷			
	L	W	T	φd	ZP50	ZP55	CP10	CP20	CP25	CK30	T20P	T10	T20
SPE 33R01	11.1	11.1	4.76	4.4									
44R01	12.7	11.7	6.35	4.4									
55R01	14.3	14.3	6.35	5.5									

◆常备库存 ◇预定库存

YCE□□

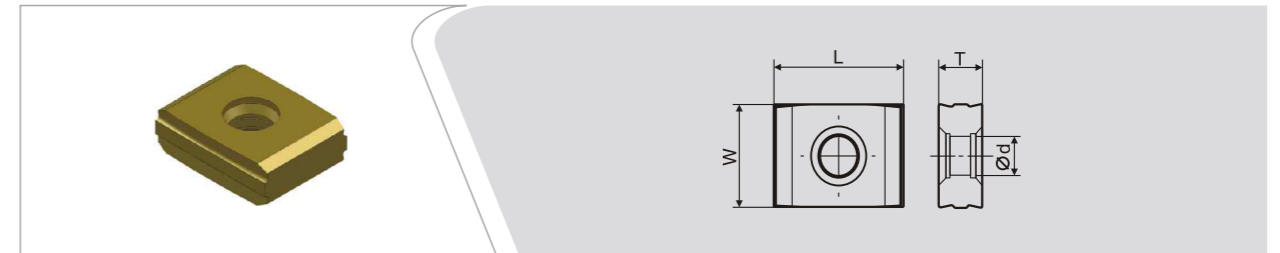

型号	尺寸				通用		CVD			金属陶瓷			
	L	W	T	φd	ZP50	ZP55	CP10	CP20	CP25	CK30	T20P	T10	T20
YCE 323-01	15.9	9.5	4.8	4.4									
434-01	19.1	14.3	6.4	5.5									

◆常备库存 ◇预定库存

CNE □ □

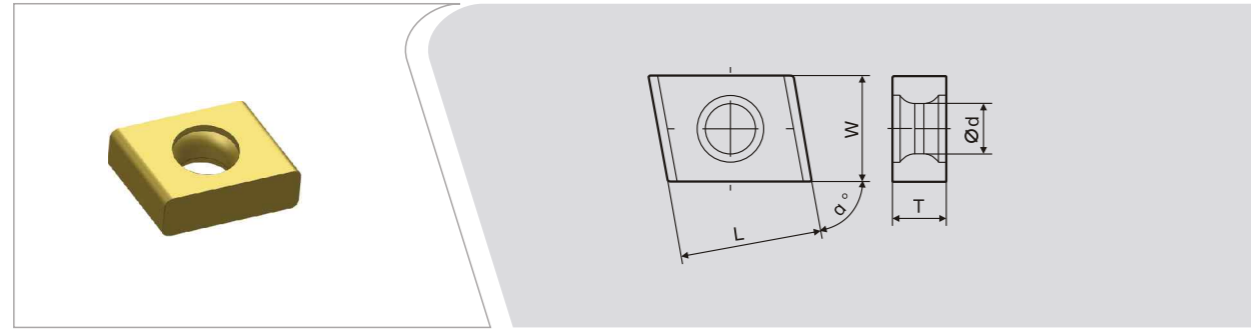

型号	尺寸				通用			CVD			金属陶瓷		
	L	W	T	φd	ZP50	ZP55	CP10	CP20	CP25	CK30	T20P	T10	T20
CNE 323	12.7	9.525	4.76	4.4	◆								
44	12.7	12.7	6.35	5.5									
454	16.3	14.3	6.35	5.5									

◆常备库存 ◇预定库存

LNE □ □

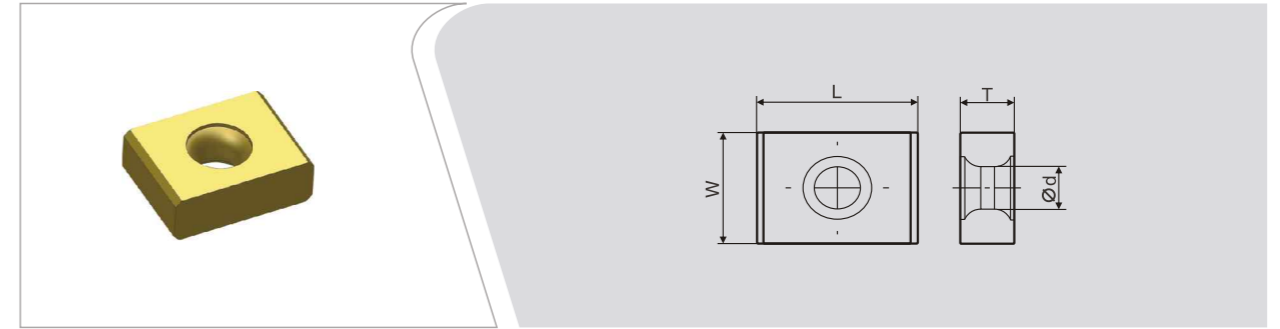

型号	尺寸				通用			CVD			金属陶瓷		
	L	W	T	φd	ZP50	ZP55	CP10	CP20	CP25	CK30	T20P	T10	T20
LNE 322-K05PH12	15.9	9.5	3.9	4.4	◆								
323-K05PH12	15.9	9.5	4.8	4.4									
323-02	15.9	9.5	4.8	4.4									
424R01	15.9	12.7	6.35	5.5									
434-02	19.1	14.3	6.35	5.5									
446R01	28.6	14.3	9.5	5.5									
446L01	28.6	14.3	9.5	5.5									

◆常备库存 ◇预定库存

LNE □ □

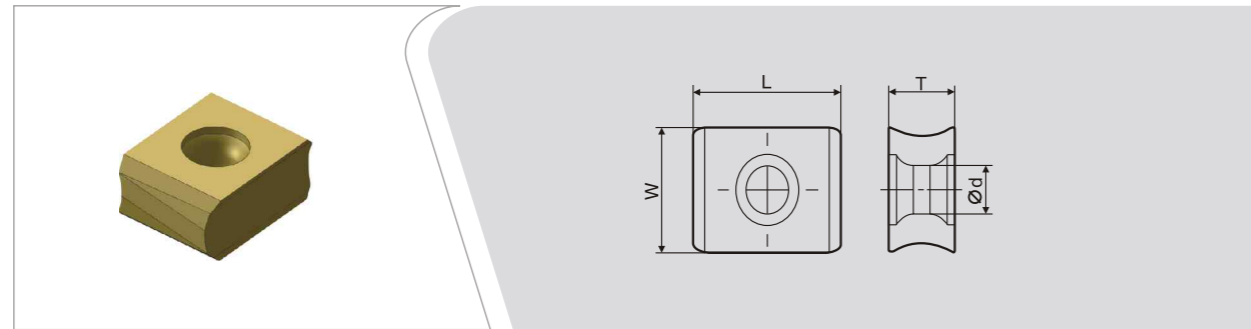

型号	尺寸				通用			CVD			金属陶瓷		
	L	W	T	φd	ZP50	ZP55	CP10	CP20	CP25	CK30	T20P	T10	T20
LNE 336R01M1	19	14.3	9.525	5.5	◆								
446R01M	28.6	16	9.525	5.5									

◆常备库存 ◇预定库存

BDE □ □

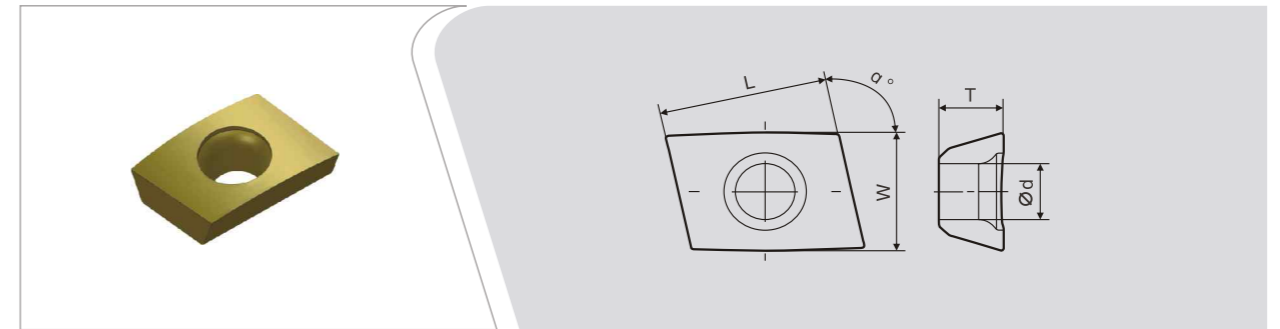

型号	尺寸				通用			CVD			金属陶瓷		
	L	W	T	φd	ZP50	ZP55	CP10	CP20	CP25	CK30	T20P	T10	T20
BDE 223R02/20	13.4	7.9	5.1	4.4	◆								
323R06/25	12.7	9.5	4.8	4.4									
323R07/32	12.7	9.5	4.8	4.4									
323R08/40	12.7	9.5	4.8	4.4									
323R09/50	14.2	9.5	4.8	4.4									
323R09/60	14.2	9.5	4.8	4.4									
434R01	20.6	12.7	6.4	5.5									

◆常备库存 ◇预定库存

CDE □ □

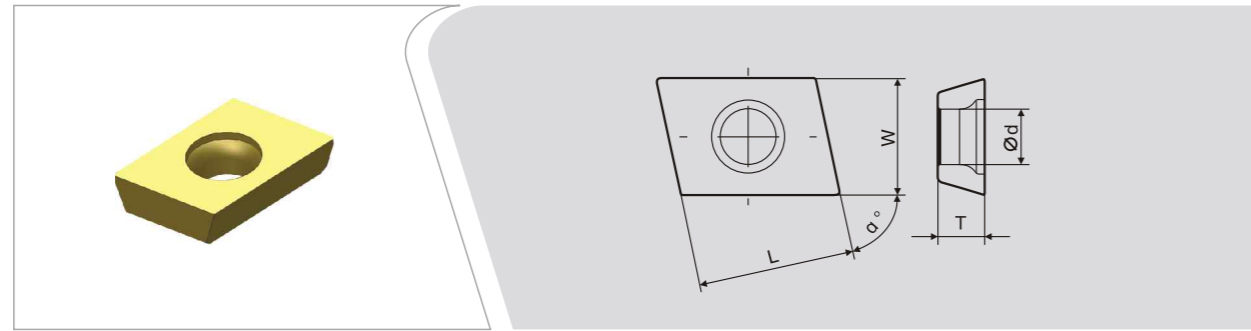

型号	尺寸				通用			CVD			金属陶瓷		
	L	W	T	φd	ZP50	ZP55	CP10	CP20	CP25	CK30	T20P	T10	T20
CDE 212L01	11.1	7.9	3.8	4.4	■	■	■	■	■	■	■	■	■
212L02	9.5	7.9	3.8	4.4	■	■	■	■	■	■	■	■	■
313R01/L01	9.5	11.1	4.8	4.4	■	■	■	■	■	■	■	■	■
322L14	13.9	9.5	3.8	4.4	■	■	■	■	■	■	■	■	■
322R01/L01	12.7	9.5	3.8	4.4	■	■	■	■	■	■	■	■	■
322R04	12.7	9.5	3.8	4.4	■	■	■	■	■	■	■	■	■
322R05/L05	12.7	9.5	3.8	4.4	■	■	■	■	■	■	■	■	■
323R05/L05	12.7	9.5	4.8	4.4	■	■	■	■	■	■	■	■	■
333R01	14.8	11.1	4.8	4.4	■	■	■	■	■	■	■	■	■
334R01/L01	19.1	9.5	6.4	4.4	■	■	■	■	■	■	■	■	■
334R04	19.1	9.5	6.4	4.4	■	■	■	■	■	■	■	■	■

◆常备库存 ◇预定库存

APKT □ □

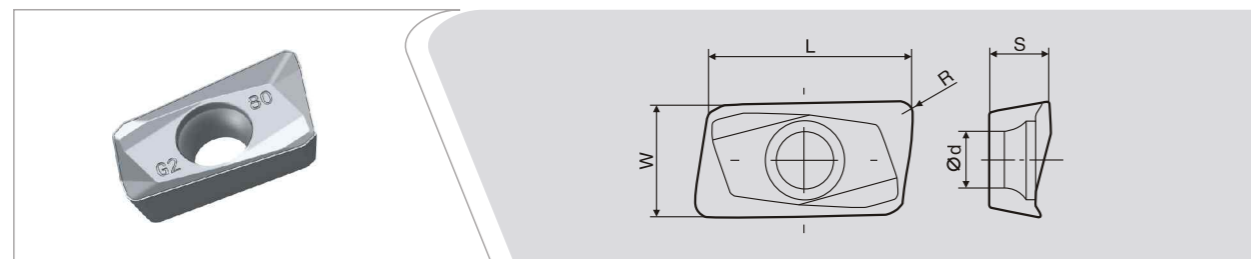

型号	尺寸				通用			CVD			金属陶瓷		
	L	W	S	φd	ZP50	ZP55	CP10	CP20	CP25	CK30	T20P	T10	T20
APKT 1135PDER-G2	11	6.35	3.5	2.8	■	■	■	■	■	■	■	■	■
1604PDER-G2	16.5	9.525	4.76	4.4	■	■	■	■	■	■	■	■	■

◆常备库存 ◇预定库存

AP** □ □

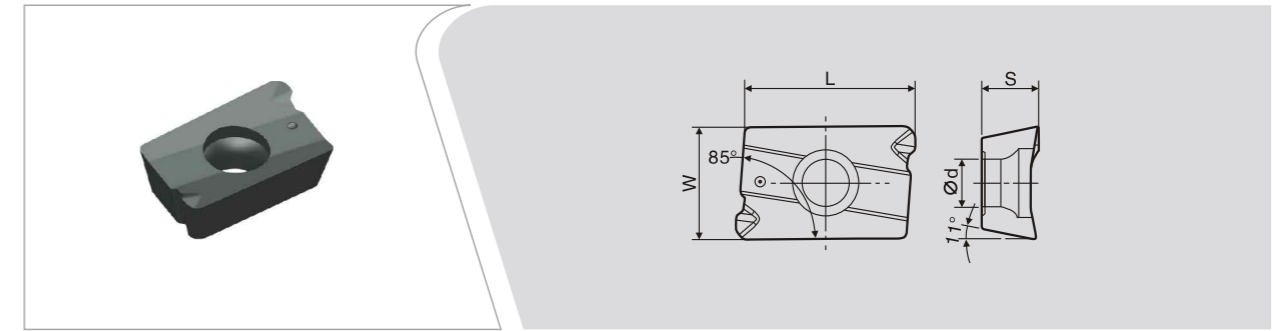

型号	尺寸				通用			CVD			金属陶瓷		
	L	W	S	φd	ZP50	ZP55	CP10	CP20	CP25	CK30	T20P	T10	T20
APLX 1003PDTR-LM	10.5	6.6	3.2	2.8	■	■	■	■	■	■	■	■	■
APKT 1604PDTR-LM	16.5	9.6	4.8	4.4	■	■	■	■	■	■	■	■	■

◆常备库存 ◇预定库存

XOEX □ □

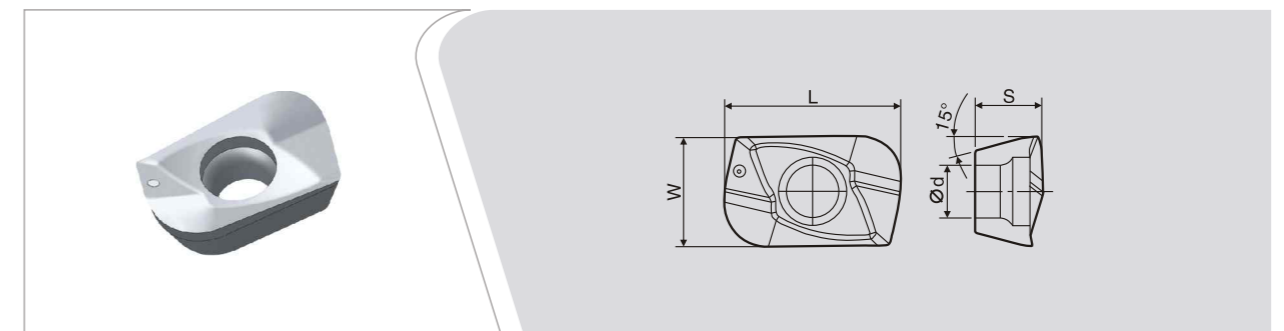

型号	尺寸				通用			CVD			金属陶瓷		
	L	W	S	φd	ZP50	ZP55	CP10	CP20	CP25	CK30	T20P	T10	T20
XOEX 120431R-SG	13.2	8.2	5.05	3.9	■	■	■	■	■	■	■	■	■
					■	■	■	■	■	■	■	■	■
					■	■	■	■	■	■	■	■	■
					■	■	■	■	■	■	■	■	■
					■	■	■	■	■	■	■	■	■

◆常备库存 ◇预定库存

A 车刀系列

B 铣刀系列

C 槽刀系列

D 螺纹刀片系列

A 车刀系列

B 铣刀系列

C 槽刀系列

D 螺纹刀片系列

QOMT□□

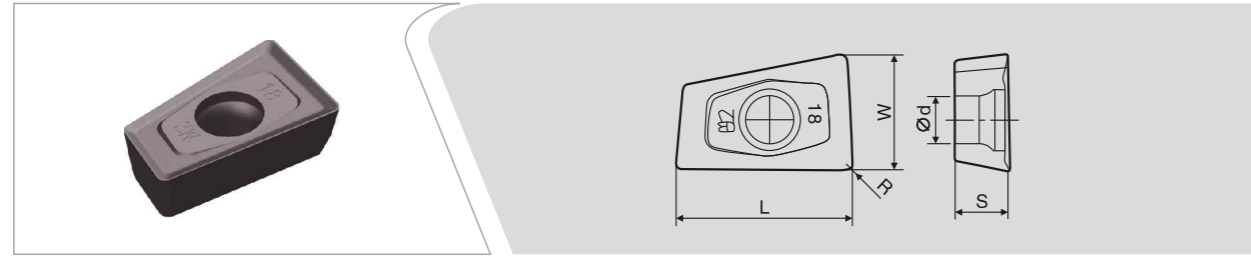

型号	尺寸				通用		CVD			金属陶瓷			
	L	W	S	φd	ZP50	ZP55	CP10	CP20	CP25	CK30	T20P	T10	T20
QOMT 1035R-M2S	10.5	6.9	3.5	3									
1342R-M2S	13	8.7	4.2	3.6									
1856R-M2S	18.2	12	5.4	4.8									
2062R-M2S	20.2	13.5	6	5.8									

◆常备库存 ◇预定库存

APKT□□

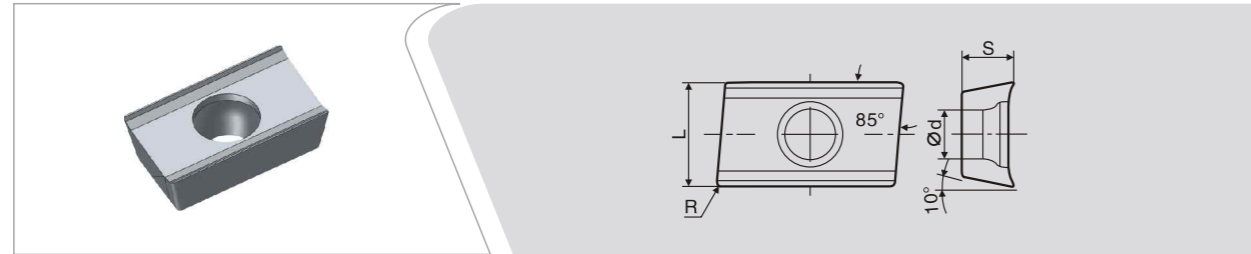

型号	尺寸				通用		CVD			金属陶瓷			
	L	S	φd	R	ZP50	ZP55	CP10	CP20	CP25	CK30	T20P	T10	T20
APKT 160402PDFR-MA	9.525	4.76	4.5	0.2									
160404PDFR-MA	9.525	4.76	4.5	0.4									
160408PDFR-MA	9.525	4.76	4.5	0.8									

◆常备库存 ◇预定库存

SEHT□□

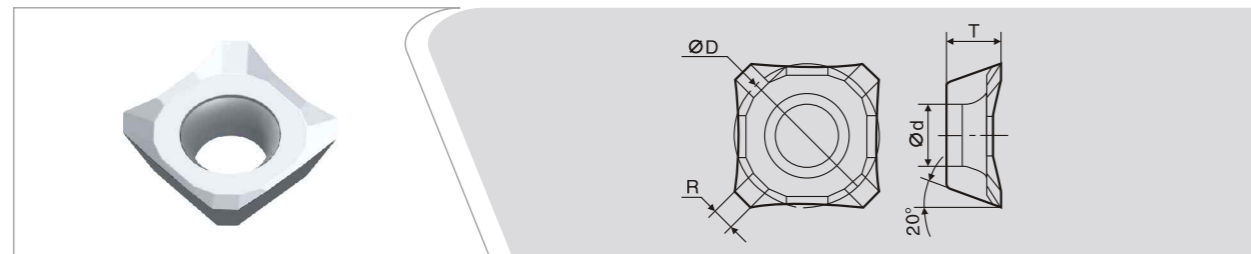

型号	尺寸				通用		CVD			金属陶瓷			
	φD	T	φd	R	ZP50	ZP55	CP10	CP20	CP25	CK30	T20P	T10	T20
SEHT 1204AFFN	12.7	4.76	5.5	0.4									

◆常备库存 ◇预定库存

SEMT□□

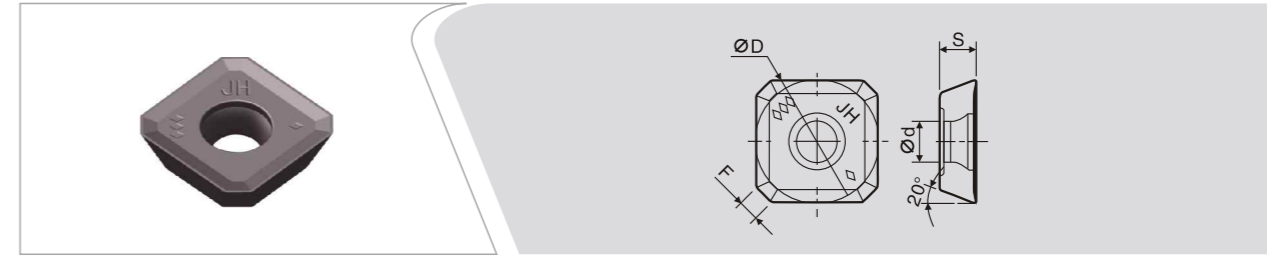

型号	尺寸				通用		CVD			金属陶瓷			
	φD	S	φd	F	ZP50	ZP55	CP10	CP20	CP25	CK30	T20P	T10	T20
SEMT 13T3AGSN-JHS	13.4	3.97	4.4	2.2									

◆常备库存 ◇预定库存

SEET□□

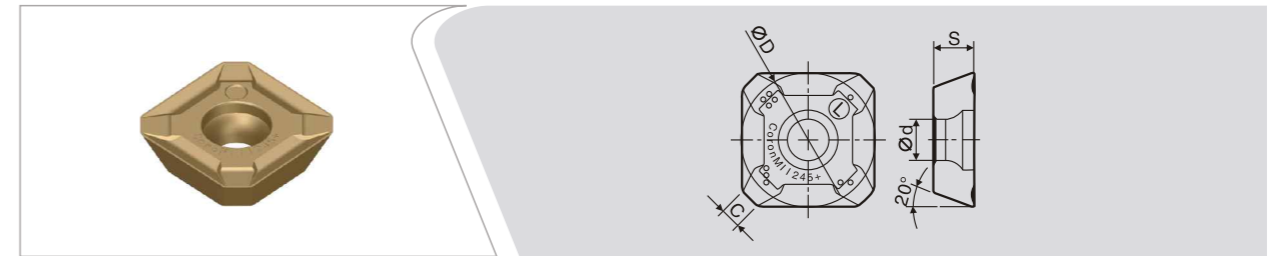

型号	尺寸				通用		CVD			金属陶瓷			
	φD	S	φd	C	ZP50	ZP55	CP10	CP20	CP25	CK30	T20P	T10	T20
SEET 12T3AGEN	13.4	3.97	4.1	2									

◆常备库存 ◇预定库存

SOMT□□

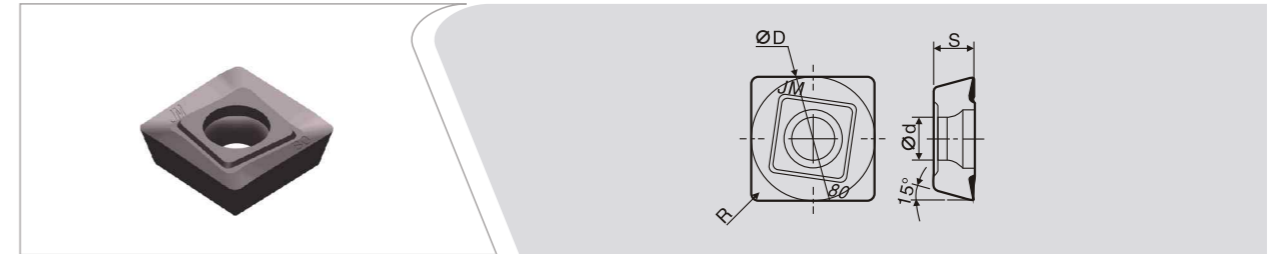

型号	尺寸				通用		CVD			金属陶瓷			
	φD	S	φd	R	ZP50	ZP55	CP10	CP20	CP25	CK30	T20P	T10	T20
SOMT 12T308PEER-JMS	12.7	3.97	4.3	0.8									

◆常备库存 ◇预定库存

SOMT

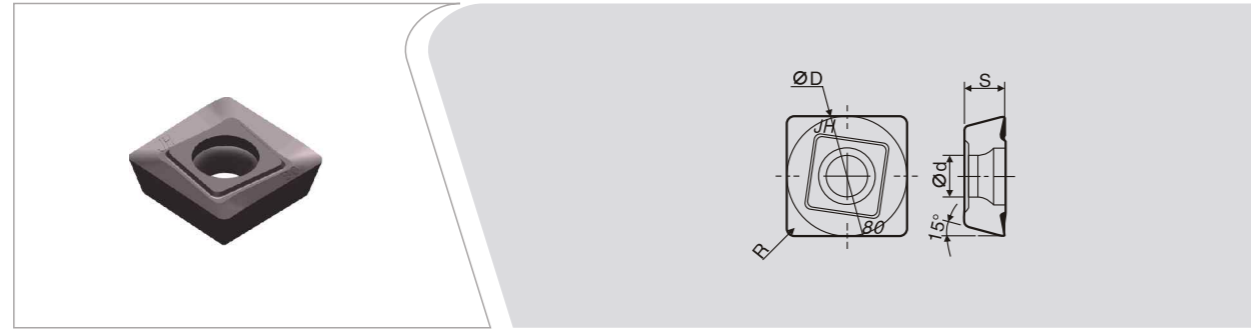

型号	尺寸				通用		CVD			金属陶瓷			
	ϕD	S	ϕd	R	ZP50	ZP55	CP10	CP20	CP25	CK30	T20P	T10	T20
SOMT 12T308PEER-JHS	12.7	3.97	4.3	0.8									

◆常备库存 ◇预定库存

RCM*

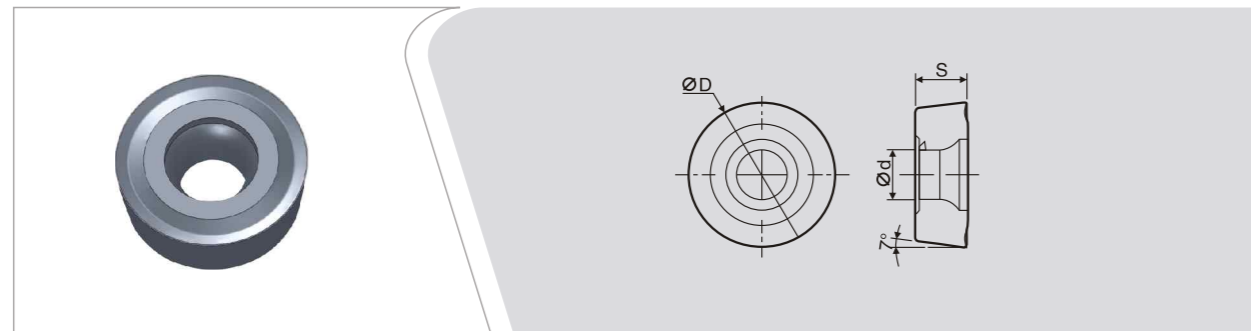

型号	尺寸			通用		CVD			金属陶瓷			
	ϕD	S	ϕd	ZP50	ZP55	CP10	CP20	CP25	CK30	T20P	T10	T20
RCMT 0602MO-61D	6	3.18	3.4									
0803MO-61D	8	3.18	3.4									
RCMM 1003MO-61D	10	3.18	4.4									
1204MO-61D	12	4.76	4.4									

◆常备库存 ◇预定库存

R245-

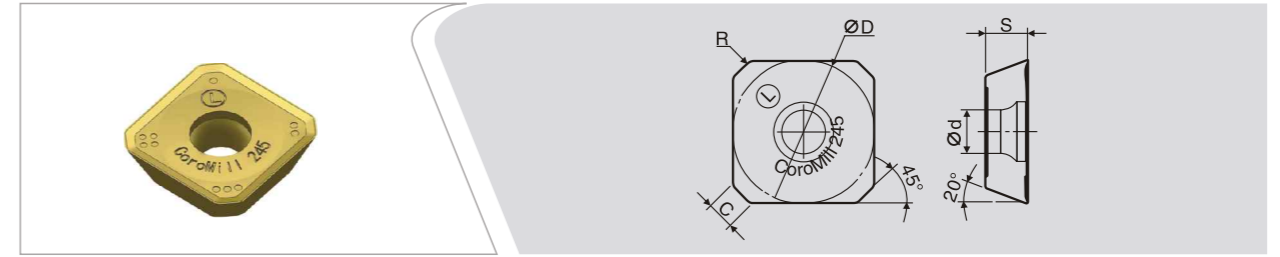

型号	尺寸				通用		CVD			金属陶瓷			
	ϕD	S	ϕd	C	ZP50	ZP55	CP10	CP20	CP25	CK30	T20P	T10	T20
R245- 12T3 M-PM	13.4	3.97	4.1	1.5									
18T6 M-PM	18	6.1	5.7	2									

◆常备库存 ◇预定库存

TPKN

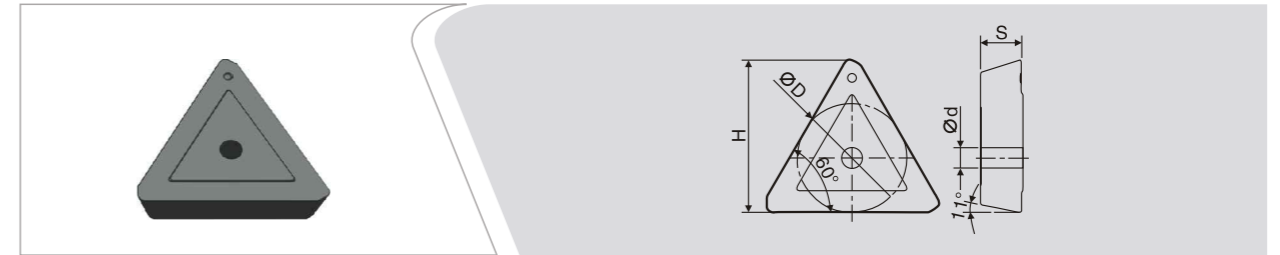

型号	尺寸				通用		CVD			金属陶瓷			
	ϕD	S	ϕd	R	ZP50	ZP55	CP10	CP20	CP25	CK30	T20P	T10	T20
TPKN 1604PDTR-LN	9.525	4.76	2.2	17.8									
2204PDTR-LN	12.7	4.76	2.2	13.3									

◆常备库存 ◇预定库存

SPKN

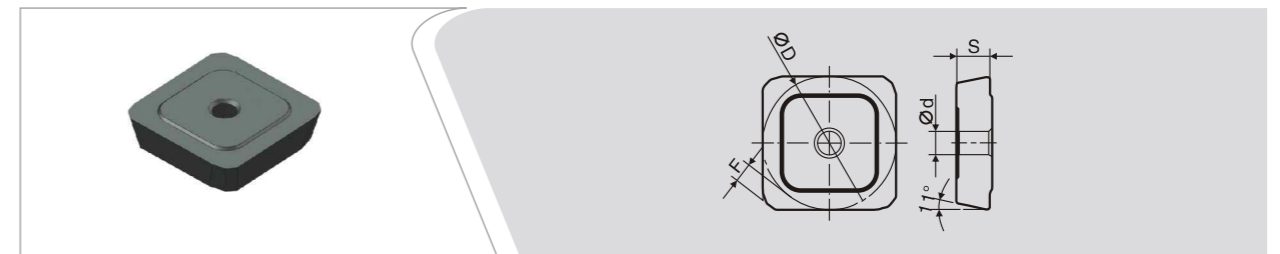

型号	尺寸				通用		CVD			金属陶瓷			
	ϕD	S	ϕd	F	ZP50	ZP55	CP10	CP20	CP25	CK30	T20P	T10	T20
SPKN 1203EDRP-LN	12.7	3.18	2.2	1.8									

◆常备库存 ◇预定库存

490R-□□

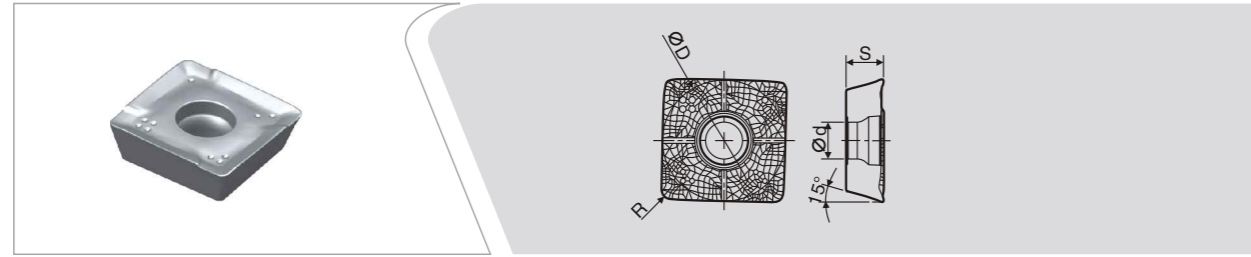

型号	尺寸				通用							CVD			金属陶瓷								
	φD	S	φd	R	ZP50	ZP55	CP10	CP20	CP25	CK30	T20P	T10	T20	ZP50	ZP55	CP10	CP20	CP25	CK30	T20P	T10	T20	
490R- 140408M-PM	13.9	4.2	4.2	0.8																			

◆常备库存 ◇预定库存

345R-□□

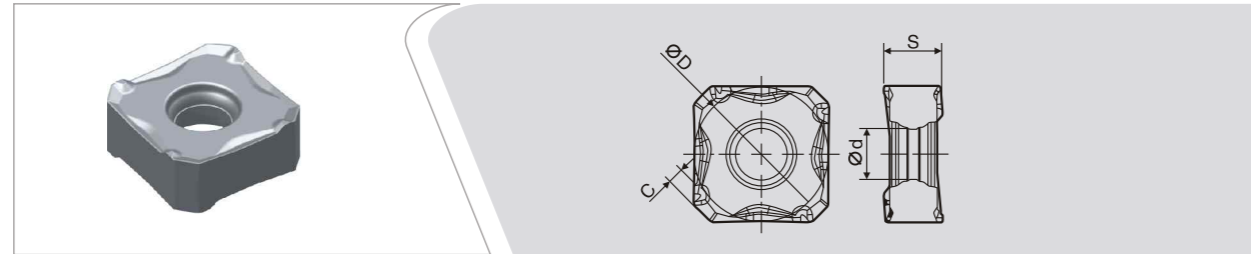

型号	尺寸				通用							CVD			金属陶瓷								
	φD	S	φd	c	ZP50	ZP55	CP10	CP20	CP25	CK30	T20P	T10	T20	ZP50	ZP55	CP10	CP20	CP25	CK30	T20P	T10	T20	
345R- 1305M-PM	13	5.56	4.8	1.6																			

◆常备库存 ◇预定库存

DFR□□

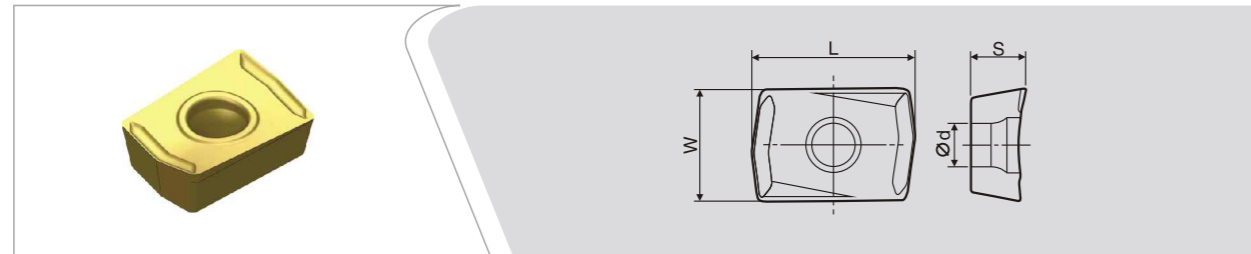

型号	尺寸				通用							CVD			金属陶瓷								
	L	S	W	φd	ZP50	ZP55	CP10	CP20	CP25	CK30	T20P	T10	T20	ZP50	ZP55	CP10	CP20	CP25	CK30	T20P	T10	T20	
DFR 020204GD	7	2.75	4.9	2.3																			
030204GD	8.6	2.75	6	2.5																			

◆常备库存 ◇预定库存

MPHT□□

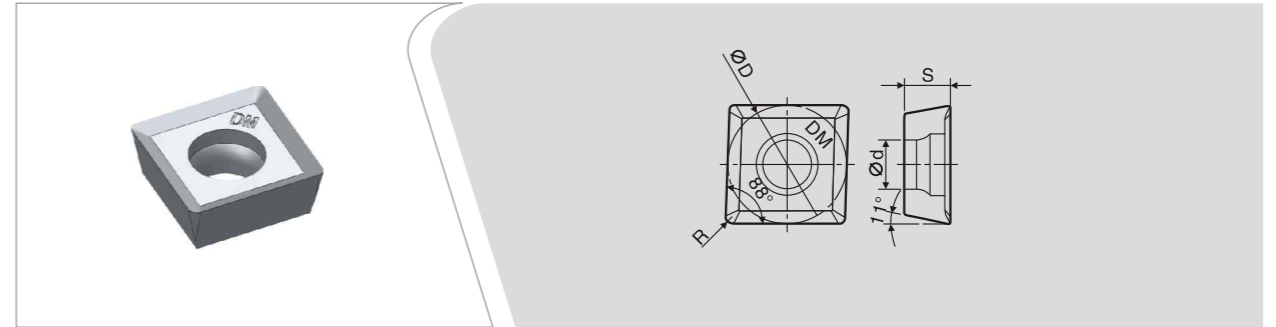

型号	尺寸				通用							CVD			金属陶瓷								
	φD	S	φd	R	ZP50	ZP55	CP10	CP20	CP25	CK30	T20P	T10	T20	ZP50	ZP55	CP10	CP20	CP25	CK30	T20P	T10	T20	
MPHT 060304-DM	6.35	3.18	2.8	0.4																			
080305-DM	8.3	3.18	3.4	0.5																			
120408-DM	12.7	4.76	5.56	0.8																			
120416-DM	12.7	4.76	5.56	1.6																			

◆常备库存 ◇预定库存

ZPFG□□

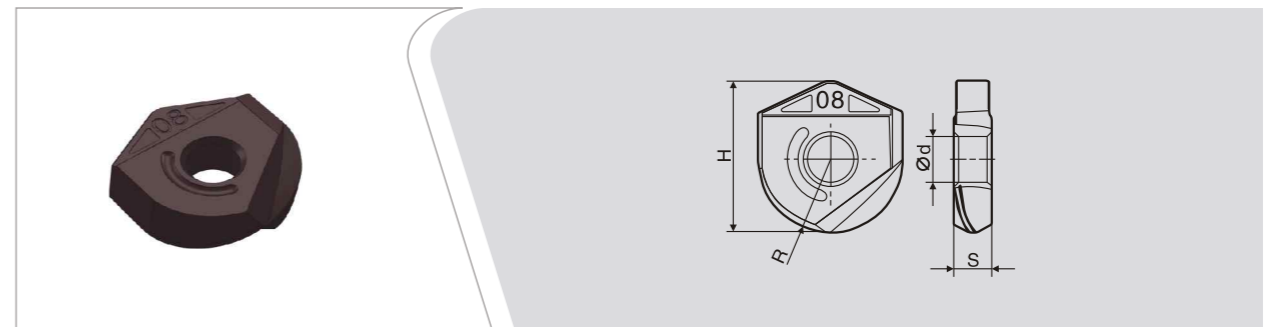

型号	尺寸				通用							CVD			金属陶瓷								
	H	R	S	φd	ZP50	ZP55	CP10	CP20	CP25	CK30	T20P	T10	T20	ZP50	ZP55	CP10	CP20	CP25	CK30	T20P	T10	T20	
ZPFG 100A	12.1	5	2.7	4																			
120A	14.6	6	3.2	5																			
160A	16.6	8	4.2	5																			
200A	20.3	10	5.2	6																			
250A	24.1	12	6.2	6																			
300A	29.4	15	7.2	8																			

◆常备库存 ◇预定库存

TNMX□□

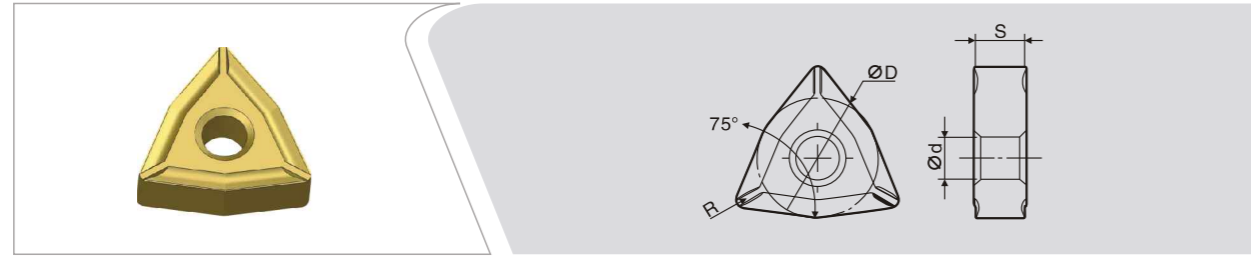

型号	尺寸				通用		CVD			金属陶瓷			
	ϕD	S	ϕd	R	ZP50	ZP55	CP10	CP20	CP25	CK30	T20P	T10	T20
TNMX 1509-N	22.22	9.7	8.1	1.6									

◆常备库存 ◇预定库存

TNMX□□

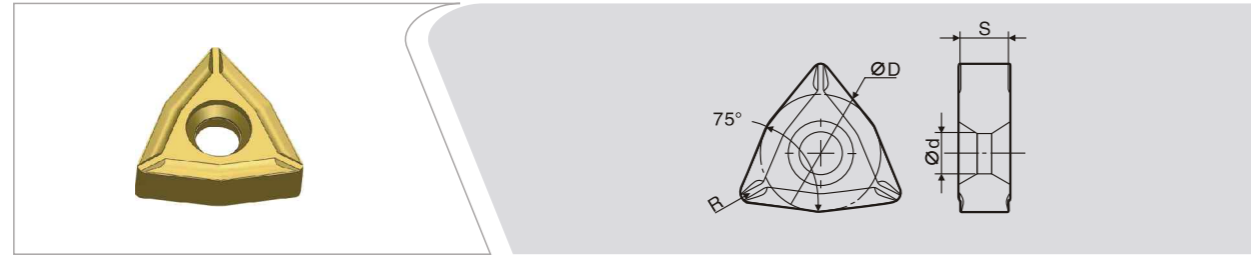

型号	尺寸				通用		CVD			金属陶瓷			
	ϕD	S	ϕd	R	ZP50	ZP55	CP10	CP20	CP25	CK30	T20P	T10	T20
TNMX 1509-2	22.22	9.525	8	1.6									

◆常备库存 ◇预定库存

XCET□□

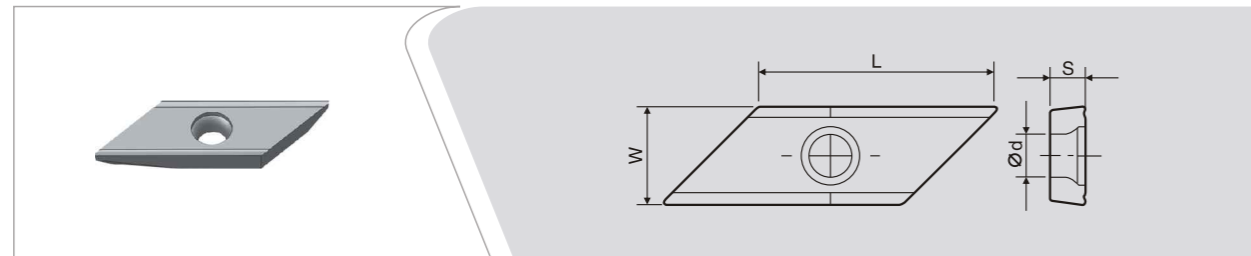

型号	尺寸				通用		CVD			金属陶瓷			
	L	W	S	ϕd	ZP50	ZP55	CP10	CP20	CP25	CK30	T20P	T10	T20
XCET 180402ER	17.2	9.525	4	5									
310404ER	30.2	12.7	4.5	5.5									

◆常备库存 ◇预定库存

LNGW□□

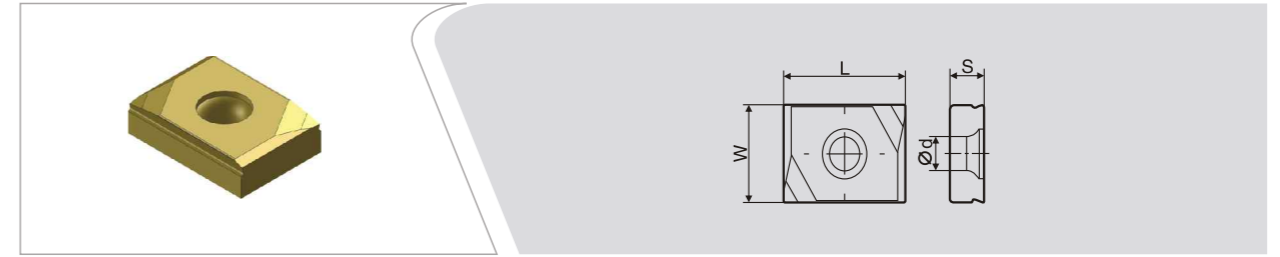

型号	尺寸				通用		CVD			金属陶瓷			
	L	W	S	ϕd	ZP50	ZP55	CP10	CP20	CP25	CK30	T20P	T10	T20
LNGW 120804	12	8	3.97	3.6									
	17	12	4.76	4.2									

◆常备库存 ◇预定库存

SD*T□□

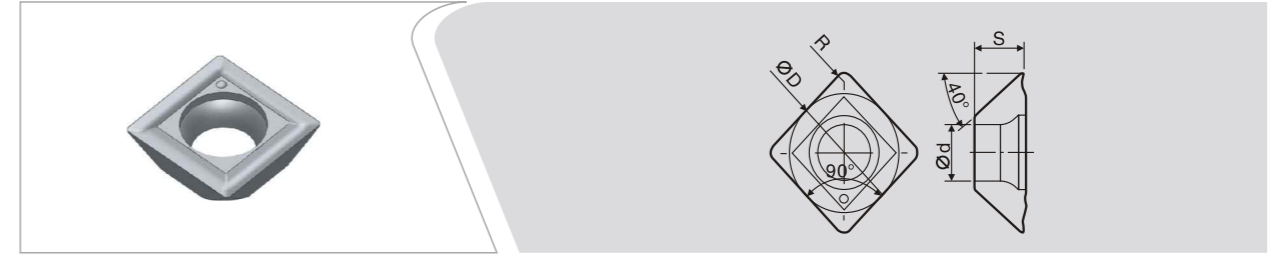

型号	尺寸				通用		CVD			金属陶瓷			
	ϕD	S	ϕd	R	ZP50	ZP55	CP10	CP20	CP25	CK30	T20P	T10	T20
SDMT 060204-UX	6	2.38	2.6	0.4									
SDGT 090204-UX	9.525	4.3	4.5	0.4									
090208-UX	9.525	4.3	4.5	0.8									

◆常备库存 ◇预定库存

LPMT□□

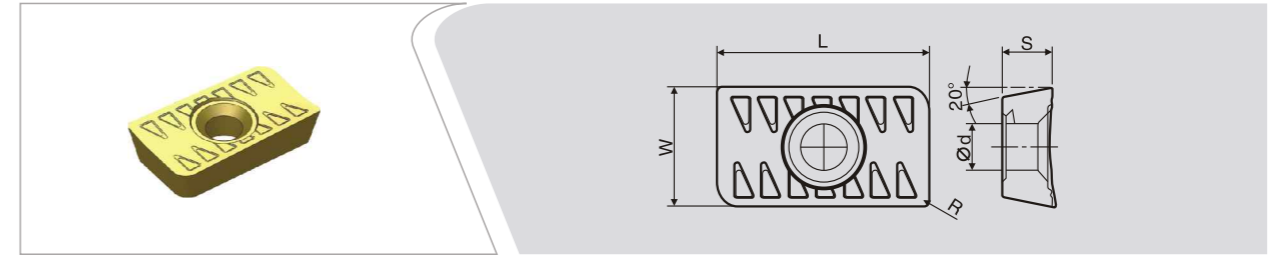

型号	尺寸				通用		CVD			金属陶瓷			
	L	S	ϕd	R	ZP50	ZP55	CP10	CP20	CP25	CK30	T20P	T10	T20
LPMT 250610-PM	25.3	6.35	5.5	0.8									

◆常备库存 ◇预定库存

ZH□□

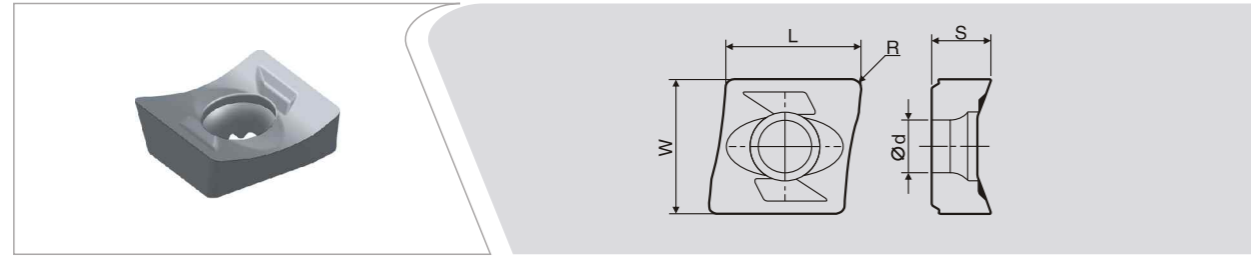

型号	尺寸				通用		CVD			金属陶瓷			
	L	W	S	ϕd	ZP50	ZP55	CP10	CP20	CP25	CK30	T20P	T10	T20
ZH 090704	12	11.8	5.1	4.6									

◆常备库存 ◇预定库存

SEMT□□

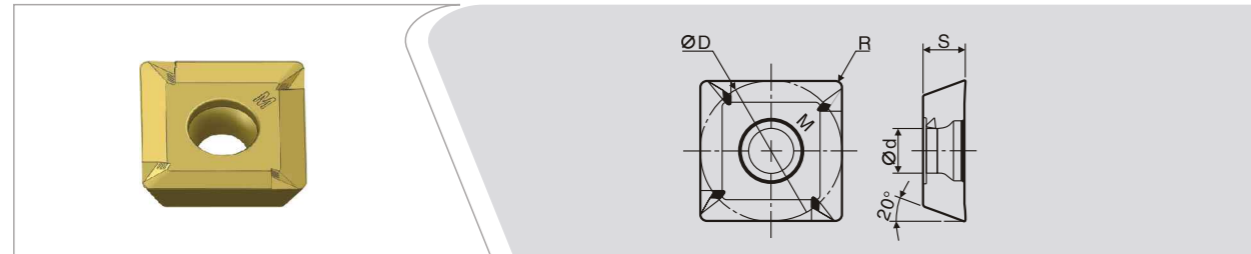

型号	尺寸				通用		CVD			金属陶瓷			
	ϕD	S	ϕd	R	ZP50	ZP55	CP10	CP20	CP25	CK30	T20P	T10	T20
SEMT 13T308-M	13.3	3.97	4.2	0.8									

◆常备库存 ◇预定库存

N331.1A-□□

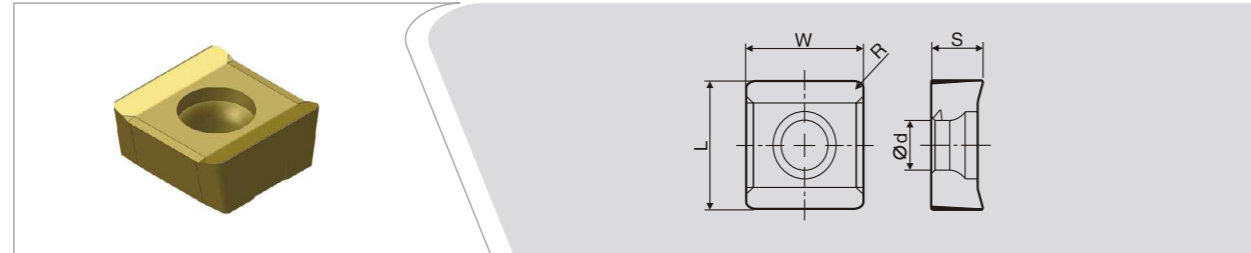

型号	尺寸				通用		CVD			金属陶瓷			
	L	W	S	R	ZP50	ZP55	CP10	CP20	CP25	CK30	T20P	T10	T20
N331.1A- 115008D-KRT	11.5	11.5	4.95	0.8									
0804508H-WL	9.5	8.5	4.95	0.8									

◆常备库存 ◇预定库存

SNMG□□

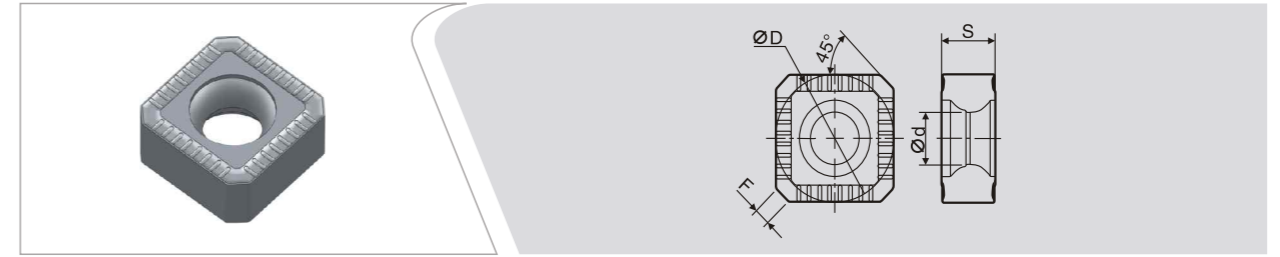

型号	尺寸				通用		CVD			金属陶瓷			
	ϕD	S	ϕd	F	ZP50	ZP55	CP10	CP20	CP25	CK30	T20P	T10	T20
SNMG 1205ANN-AF	12.7	5.56	5.2	2.0									

◆常备库存 ◇预定库存

JDMT□□

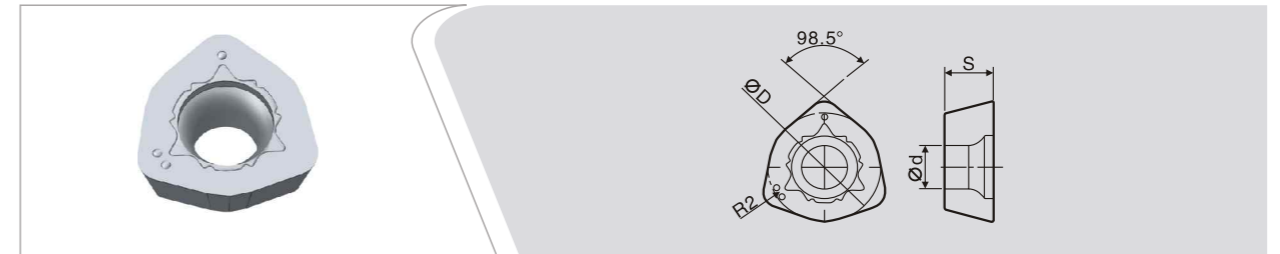

型号	尺寸				通用		CVD			金属陶瓷			
	ϕD	S	ϕd	R	ZP50	ZP55	CP10	CP20	CP25	CK30	T20P	T10	T20
JDMT 1205-FM	12.7	5.5	5.1	2									

◆常备库存 ◇预定库存

HNMG□□

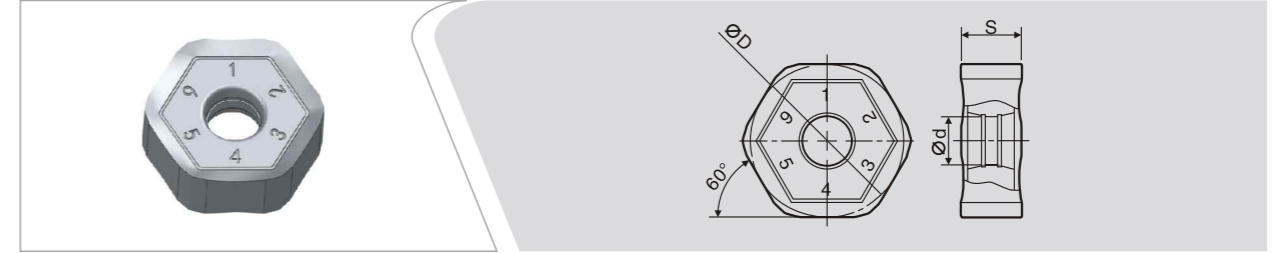

型号	尺寸				通用		CVD			金属陶瓷			
	ϕD	S	ϕd	R	ZP50	ZP55	CP10	CP20	CP25	CK30	T20P	T10	T20
HNMG 1506-GD	15.875	6.25	5	1.2									

◆常备库存 ◇预定库存

PNGG□□

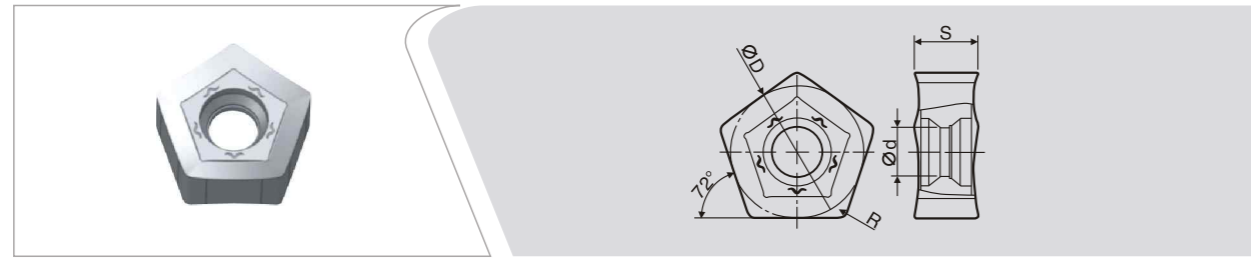

型号	尺寸				通用		CVD			金属陶瓷			
	φD	S	φd	R	ZP50	ZP55	CP10	CP20	CP25	CK30	T20P	T10	T20
PNGG 0806	12.2	6	4.5	0.8									

◆常备库存 ◇预定库存

SNMX□□

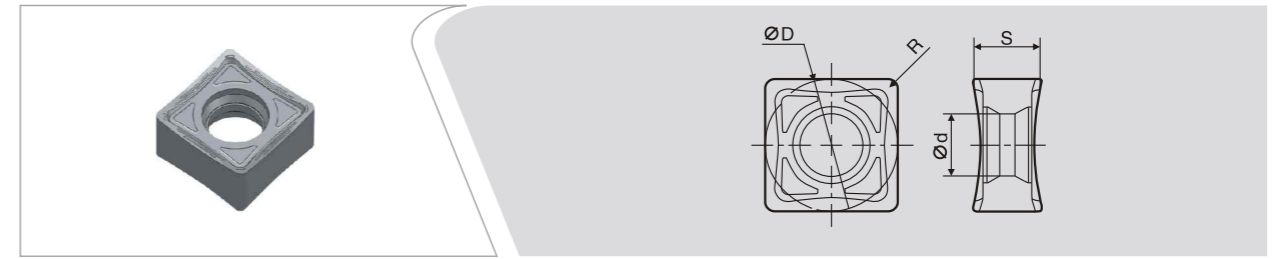

型号	尺寸				通用		CVD			金属陶瓷			
	φD	S	φd	R	ZP50	ZP55	CP10	CP20	CP25	CK30	T20P	T10	T20
SNMX 120608-GF	12.7	6.8	6	0.8									

◆常备库存 ◇预定库存

A 车刀系列

B 铣刀系列

C 槽刀系列

D 螺纹刀片系列

WNHU□□

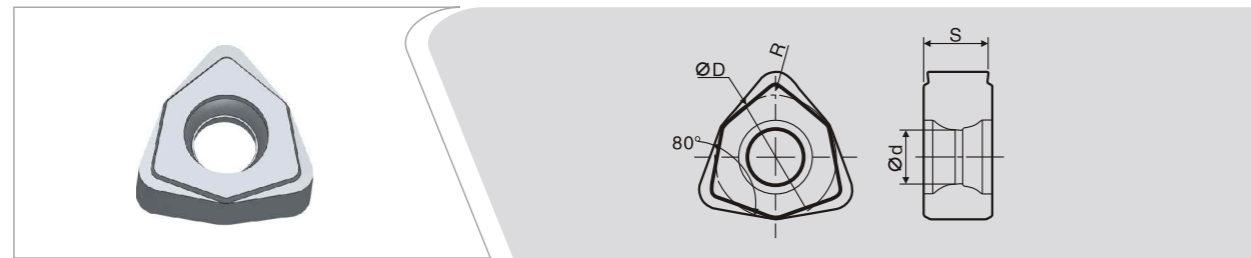

型号	尺寸				通用		CVD			金属陶瓷			
	φD	S	φd	R	ZP50	ZP55	CP10	CP20	CP25	CK30	T20P	T10	T20
WNHU 040310	6.35	3.5	2.8	1.0									

◆常备库存 ◇预定库存

ZNGG□□

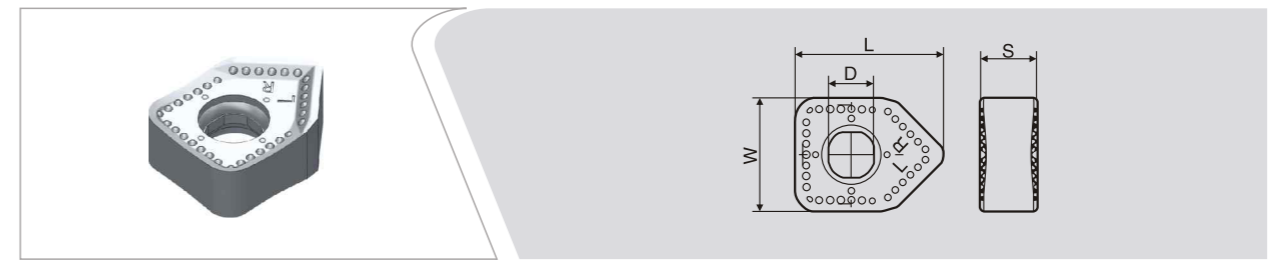

型号	尺寸				通用		CVD			金属陶瓷			
	L	W	D	S	ZP50	ZP55	CP10	CP20	CP25	CK30	T20P	T10	T20
ZNGG 120625-GT	16.75	12.7	5	6.35									

◆常备库存 ◇预定库存

SN□G□□

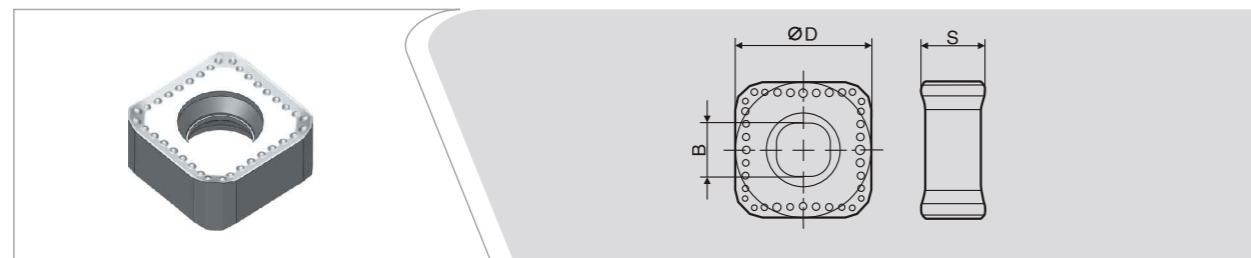

型号	尺寸			通用		CVD			金属陶瓷			
	φD	S	φd	ZP50	ZP55	CP10	CP20	CP25	CK30	T20P	T10	T20
SNGG 1206AN-GT	12.7	5	6.35									
SNMG 1507AN-GT	15.875	5.5	7.8									

◆常备库存 ◇预定库存

WNGG□□



型号	尺寸				通用		CVD			金属陶瓷			
	φD	S	φd	R	ZP50	ZP55	CP10	CP20	CP25	CK30	T20P	T10	T20
WNGG 040306	6.55	3.18	2.8	0.6									

◆常备库存 ◇预定库存

A 车刀系列

B 铣刀系列

C 槽刀系列

D 螺纹刀片系列

ZNGG□□

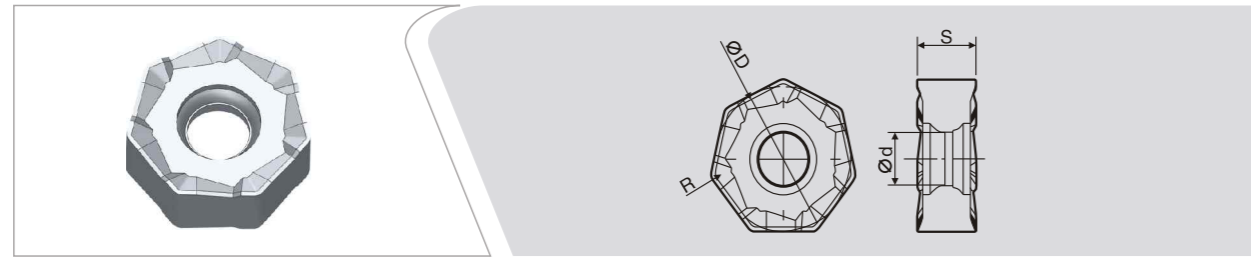

型号	尺寸				通用		CVD			金属陶瓷			
	φD	S	φd	R	ZP50	ZP55	CP10	CP20	CP25	CK30	T20P	T10	T20
ZNGG 0305-M	14.2	6.15	5.2	1									

◆常备库存 ◇预定库存

HNUG□□

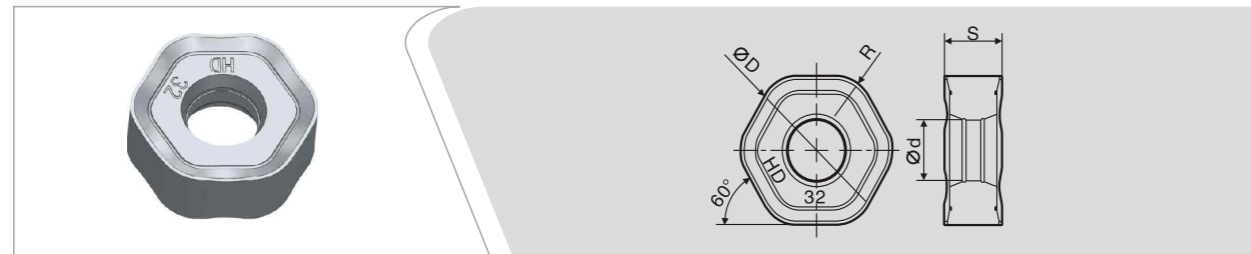

型号	尺寸				通用		CVD			金属陶瓷			
	φD	S	φd	R	ZP50	ZP55	CP10	CP20	CP25	CK30	T20P	T10	T20
HNUG 060432	12.3	5	5	3.35									

◆常备库存 ◇预定库存

WNMG□□

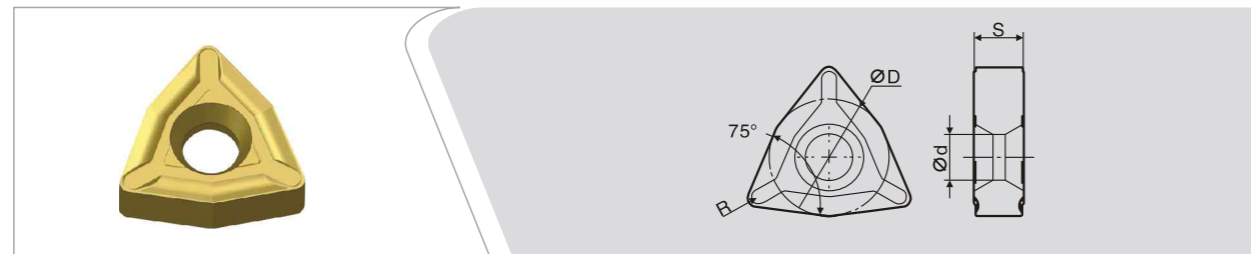

型号	尺寸				通用		CVD			金属陶瓷			
	φD	S	φd	R	ZP50	ZP55	CP10	CP20	CP25	CK30	T20P	T10	T20
WNMG 100620	15.875	6.35	6.35	2									

◆常备库存 ◇预定库存

WNUN□□

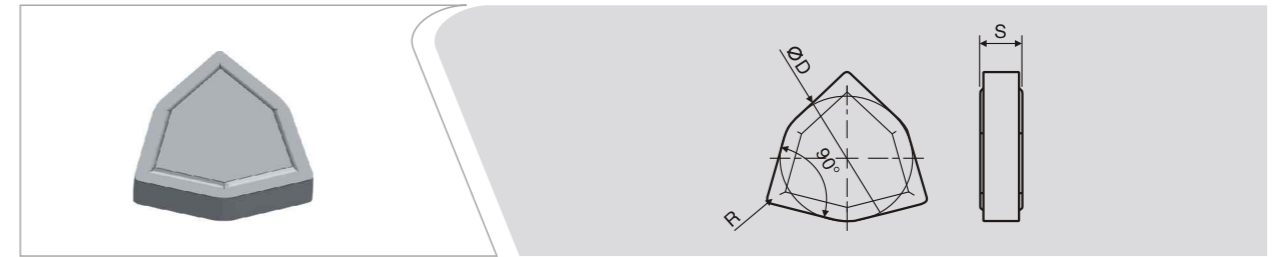

型号	尺寸			通用		CVD			金属陶瓷			
	φD	S	R	ZP50	ZP55	CP10	CP20	CP25	CK30	T20P	T10	T20
WNUN 180912	29.2	9.2	1.2									

◆常备库存 ◇预定库存

CNMU□□

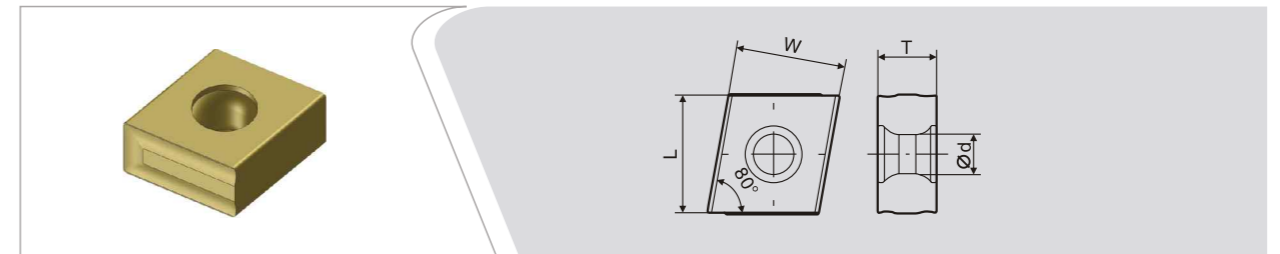

型号	尺寸				通用		CVD			金属陶瓷			
	L	W	T	φd	ZP50	ZP55	CP10	CP20	CP25	CK30	T20P	T10	T20
CNMU 095510	9	8	5	3.4									
136504	13	12	6.5	4.4									
160810	16	15	8	5.5									

◆常备库存 ◇预定库存

92.40□□

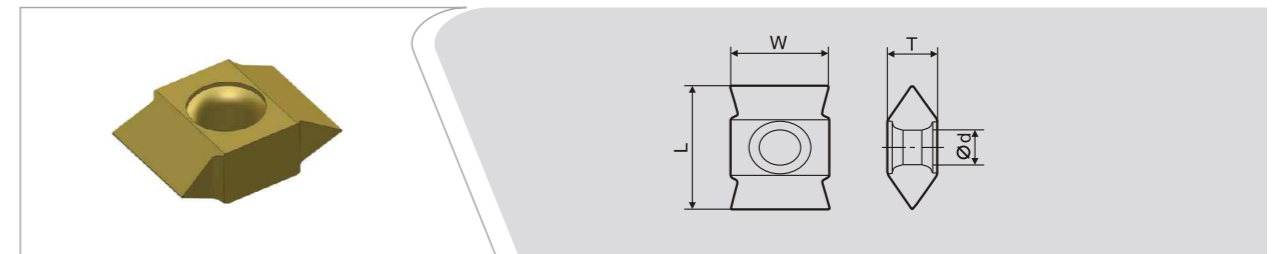

型号	尺寸				通用		CVD			金属陶瓷			
	L	W	T	φd	ZP50	ZP55	CP10	CP20	CP25	CK30	T20P	T10	T20
92.40.003.04	15.875	9.525	4.76	4.4									
92.40.103.04	19	12.7	6.35	5.5									
92.40.203.04	18.6	14.3	9.525	5.5									

◆常备库存 ◇预定库存

MGMN□□-G

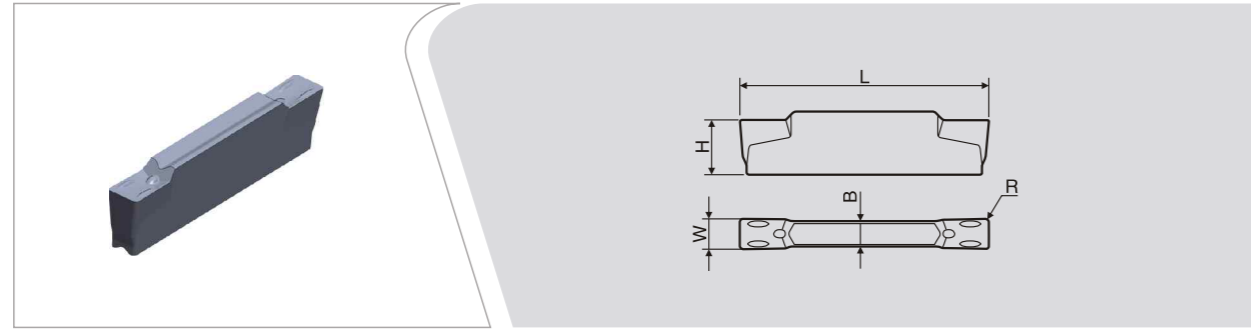

型号	尺寸				通用			CVD			金属陶瓷		
	L	W	H	R	ZP50	ZP55	CP10	CP20	CP25	CK30	T20P	T10	T20
MGMN 150-G	16	1.5	3.5	0.15	◆								
MGMN 200-G	16	2	3.5	0.2	◆								

◆常备库存 ◇预定库存

MRMN□□-M

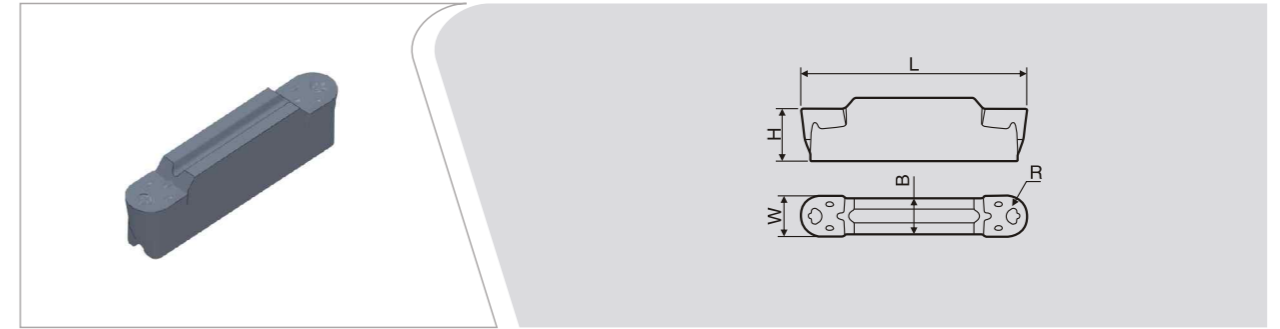

型号	尺寸				通用			CVD			金属陶瓷		
	L	W	H	R	ZP50	ZP55	CP10	CP20	CP25	CK30	T20P	T10	T20
MRMN 200-M	16	2	3.5	1.0	◆								
MRMN 300-M	21	3	4.8	1.5	◆								
MRMN 400-M	21	4	4.8	2.0	◆								
MRMN 500-M	26	5	5.8	2.5	◆								
MRMN 600-M	26	6	5.8	3.0	◆								

◆常备库存 ◇预定库存

MGMN□□-M

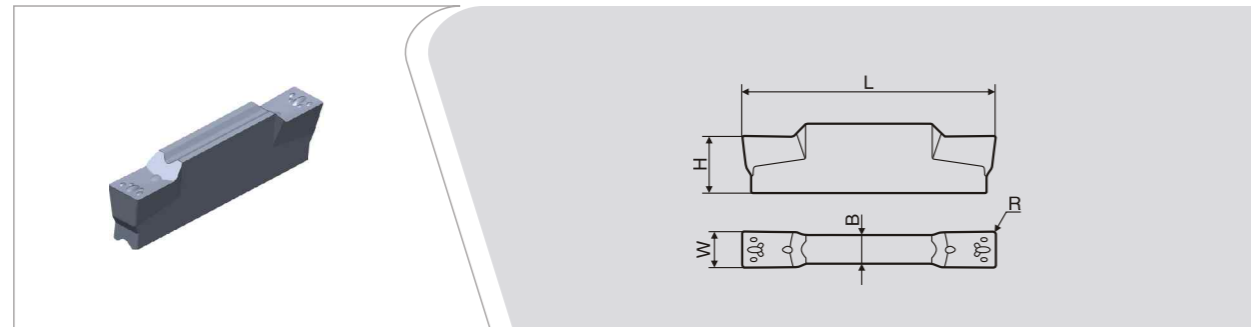

型号	尺寸				通用			CVD			金属陶瓷		
	L	W	H	R	ZP50	ZP55	CP10	CP20	CP25	CK30	T20P	T10	T20
MGMN 200-M	16	2	3.5	0.2	◆								
MGMN 250-M	18.5	2.5	3.85	0.2	◆								
MGMN 300-M	21	3	4.8	0.4	◆								
MGMN 400-M	21	4	4.8	0.4	◆								
MGMN 500-M	26	5	5.8	0.8	◆								
MGMN 600-M	26	6	5.8	0.8	◆								

◆常备库存 ◇预定库存

MGMN□□-T

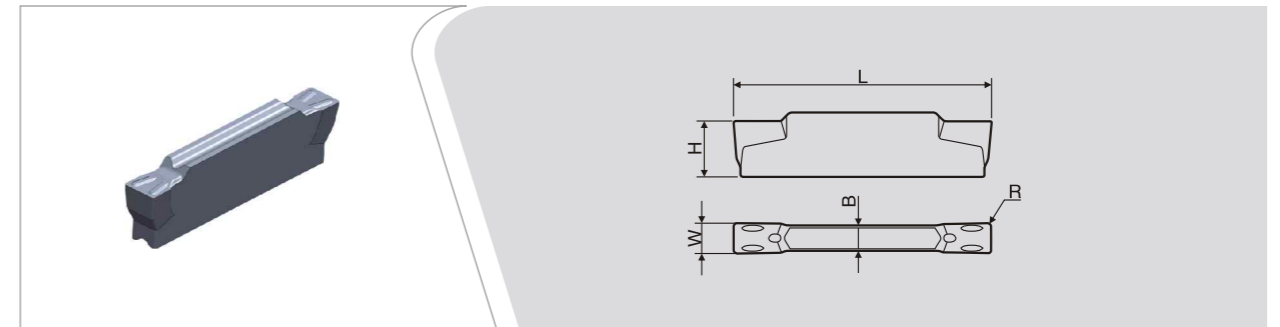

型号	尺寸				通用			CVD			金属陶瓷		
	L	W	H	R	ZP50	ZP55	CP10	CP20	CP25	CK30	T20P	T10	T20
MGMN 200-T	16	2	3.5	0.2	◆								
MGMN 250-T	18.5	2.5	3.85	0.2	◆								
MGMN 300-T	21	3	4.8	0.4	◆								
MGMN 400-T	21	4	4.8	0.4	◆								
MGMN 500-T	26	5	5.8	0.8	◆								

◆常备库存 ◇预定库存

A 车刀系列

B 铣刀系列

C 槽刀系列

D 螺纹刀片系列

A 车刀系列

B 铣刀系列

C 槽刀系列

D 螺纹刀片系列

MGGN□□

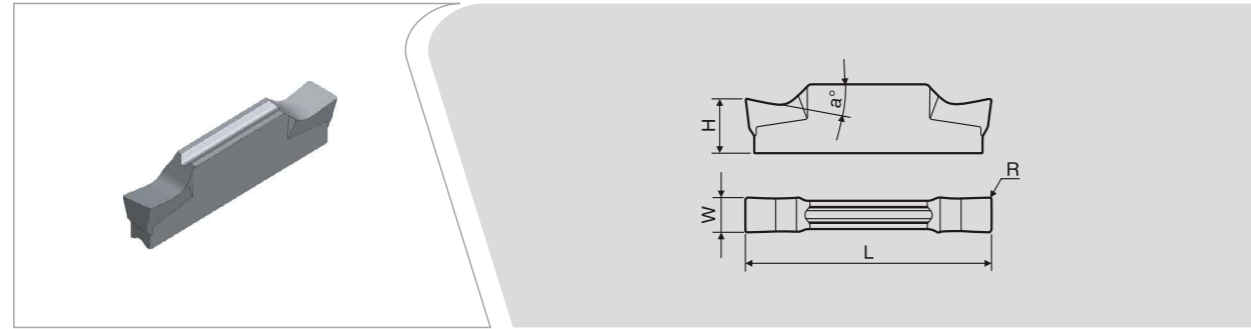

型号	尺寸				通用			CVD			金属陶瓷		
	L	W	H	R	ZP50	ZP55	CP10	CP20	CP25	CK30	T20P	T10	T20
MGGN 150	16	1.5	3.4	0.15	◆								
200	16	2	3.4	0.2	◆								
250	16	2.5	3.4	0.2	◆								
300	21	3	4.7	0.4	◆								
400	21	4	4.7	0.4	◆								
500	26	5	4.7	0.4	◆								
600	26	6	4.7	0.4	◆								

◆常备库存 ◇预定库存

MGGN□□-8

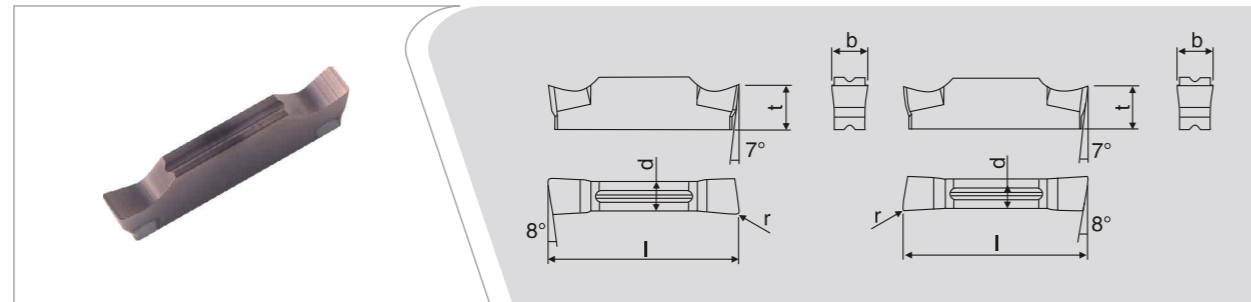

型号	尺寸					通用			CVD			金属陶瓷		
	b	r	l	d	t	ZP50	ZP55	CP10	CP20	CP25	CK30	T20P	T10	T20
MGGN 150L-8	1.5	-	16	1.2	3.5	◆								
150R-8														
200L-8	2	-	16	1.6	3.5	◆								
200R-8														
250L-8	2.5	-	18.5	2	3.85	◆								
250R-8														
300L-8	3	-	21	2.35	4.8	◆								
300R-8														
400L-8	4	-	21	3.3	4.8	◆								
400R-8														
500L-8	5	-	26	4.1	5.8	◆								
500R-8														

◆常备库存 ◇预定库存

MGMN□□-H

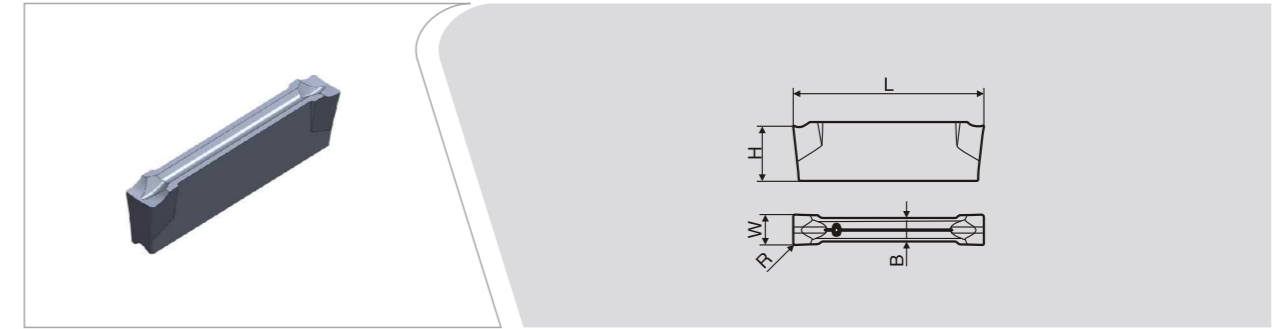

型号	尺寸				通用			CVD			金属陶瓷		
	L	W	H	R	ZP50	ZP55	CP10	CP20	CP25	CK30	T20P	T10	T20
MGMN 200-H	16	2	3.5	0.2	◆								
300-H	21	3	4.8	0.4	◆								
400-H	21	4	4.8	0.4	◆								
500-H	26	5	5.8	0.4	◆								

◆常备库存 ◇预定库存

MGMN□□-C

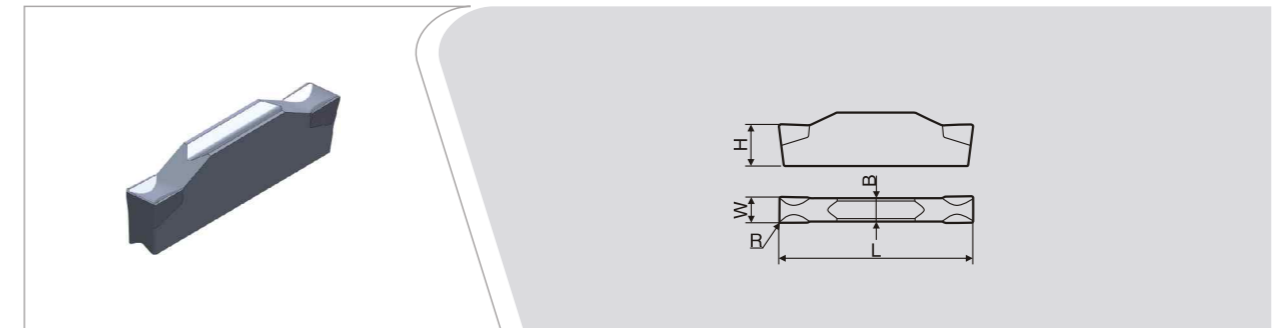

型号	尺寸				通用			CVD			金属陶瓷		
	L	W	H	R	ZP50	ZP55	CP10	CP20	CP25	CK30	T20P	T10	T20
MGMN 200-C	16	2	3.5	0.2	◆								
300-C	21	3	4.8	0.4	◆								
400-C	21	4	4.8	0.4	◆								
500-C	26	5	5.8	0.4	◆								

◆常备库存 ◇预定库存

A 车刀系列

B 铣刀系列

C 槽刀系列

D 螺纹刀片系列

A 车刀系列

B 铣刀系列

C 槽刀系列

D 螺纹刀片系列

TDJ

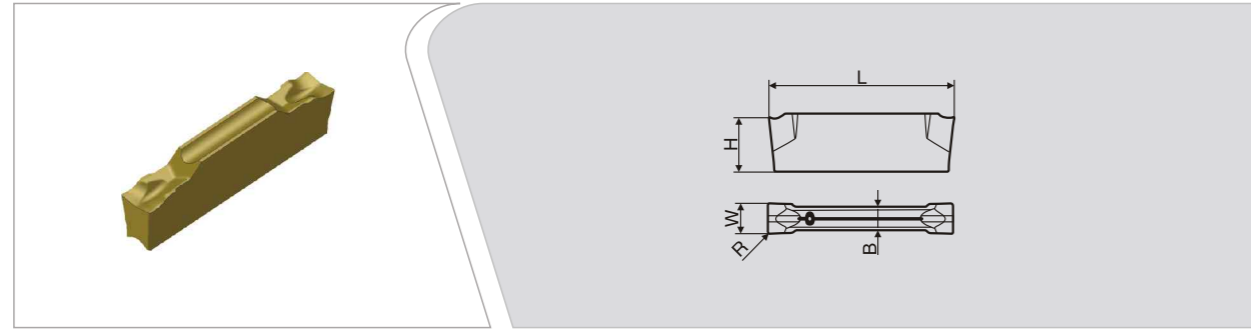

型号	尺寸				通用			CVD			金属陶瓷		
	L	W	H	R	ZP50	ZP55	CP10	CP20	CP25	CK30	T20P	T10	T20
TDJ2	20	2	4.2	0.2	◆								
TDJ3	20	3	4.2	0.2									
TDJ4	20	4	4.2	0.3									

◆常备库存 ◇预定库存

N123□□

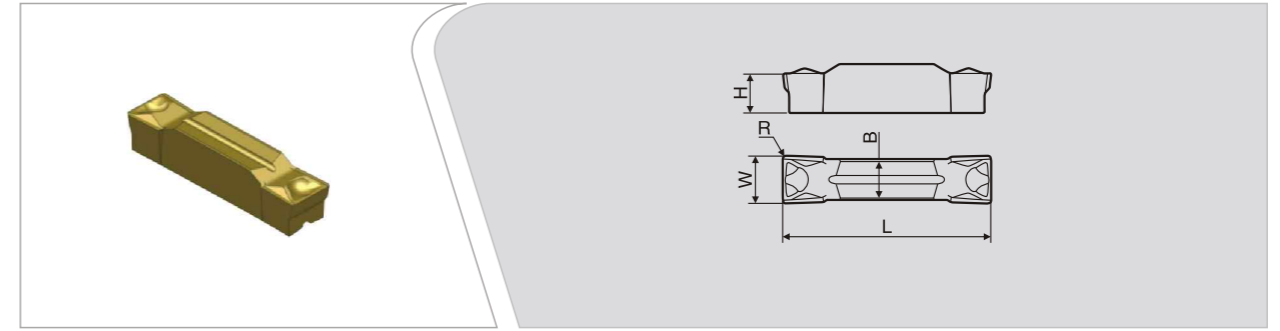

型号	尺寸				通用			CVD			金属陶瓷		
	L	W	H	R	ZP50	ZP55	CP10	CP20	CP25	CK30	T20P	T10	T20
N123K2-0600-0004-ST	25.5	6	4.8	0.4	◆								

◆常备库存 ◇预定库存

AB*□

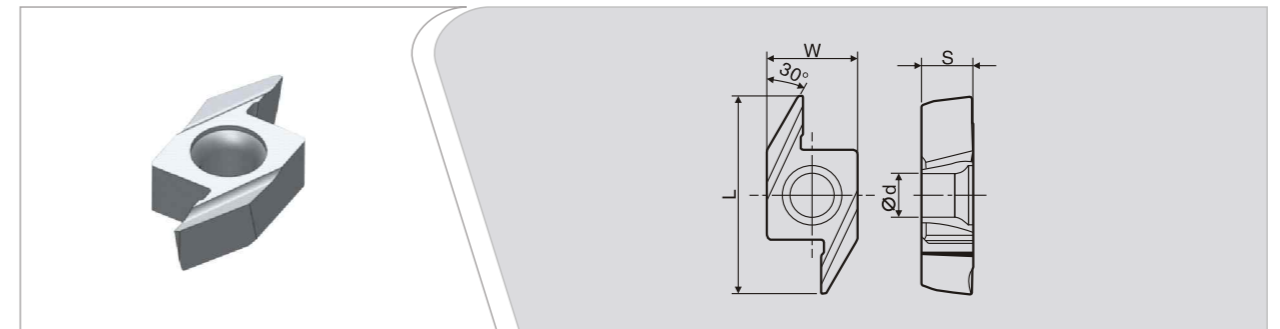

型号	尺寸				通用			CVD			金属陶瓷		
	L	W	d	S	ZP50	ZP55	CP10	CP20	CP25	CK30	T20P	T10	T20
ABS	15R4005	15.4	7	3.97	◆								
	15R4015	15.4	7	3.97									
ABW	15R4005	15.4	7	3.97									
	15R1015	15.4	7	3.97									
	23R5005	23.4	7	3.97									
	23R5015	23.4	7	3.97									

◆常备库存 ◇预定库存

TDC

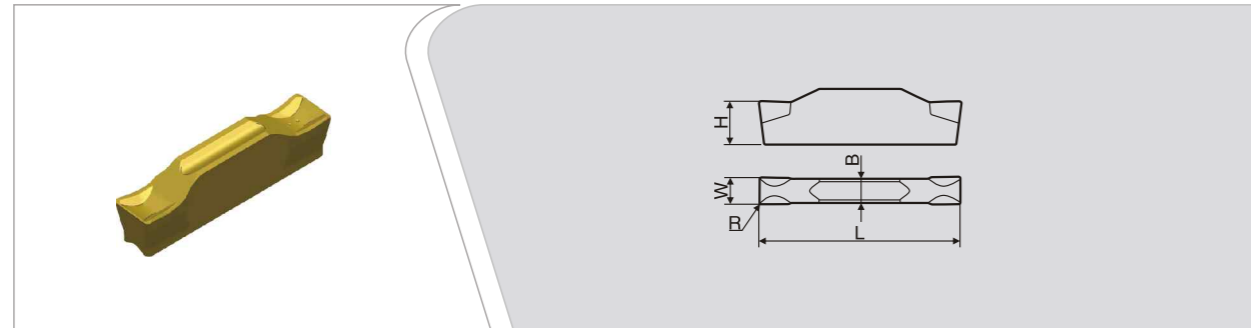

型号	尺寸				通用			CVD			金属陶瓷		
	L	W	H	R	ZP50	ZP55	CP10	CP20	CP25	CK30	T20P	T10	T20
TDC2	20	2	4.2	0.2	◆								
TDC3	20	3	4.2	0.2									
TDC4	20	4	4.2	0.2									

◆常备库存 ◇预定库存

MB-□

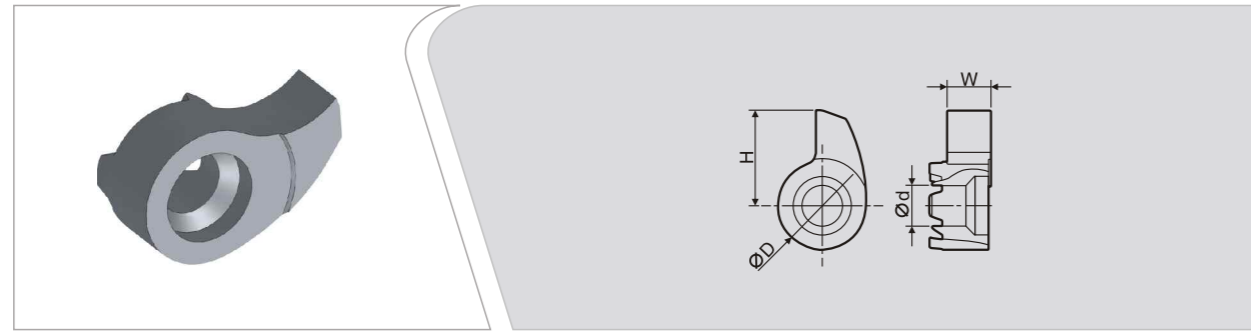

型号	尺寸				通用			CVD			金属陶瓷		
	φD	W	H	φd	ZP50	ZP55	CP10	CP20	CP25	CK30	T20P	T10	T20
MB- 05-09R	5	3.2	6.2	2.4									
07-12R	7	3.4	7.6	3.2									
09-17R	9	3.6	11.8	4.2									
11-20R	11	4.3	14.2	5.4									

◆常备库存 ◇预定库存

MIMR□□

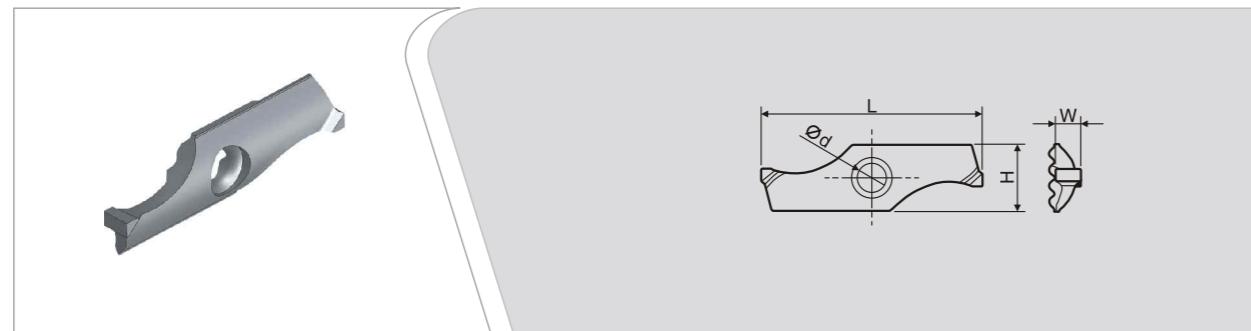

型号	尺寸				通用			CVD			金属陶瓷		
	L	H	W	φd	ZP50	ZP55	CP10	CP20	CP25	CK30	T20P	T10	T20
MIMR 08200	21	6.35	2.4	2.8									

◆常备库存 ◇预定库存

TL□□

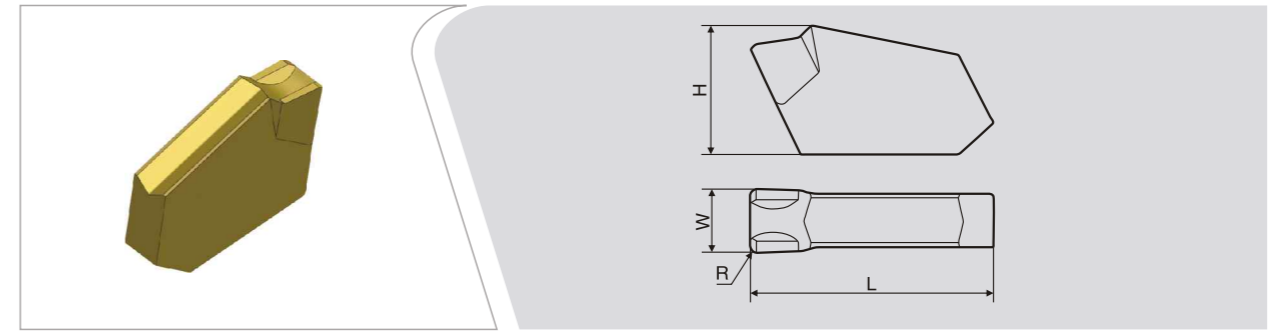

型号	尺寸				通用			CVD			金属陶瓷		
	L	H	W	R	ZP50	ZP55	CP10	CP20	CP25	CK30	T20P	T10	T20
TL 1402	14	7.4	2	0.2									
1403	14	7.4	3	0.2									
1404	14	7.4	4	0.2									
1405	14	7.8	5	0.4									
1406	14	8.35	6	0.4									

◆常备库存 ◇预定库存

KT□□

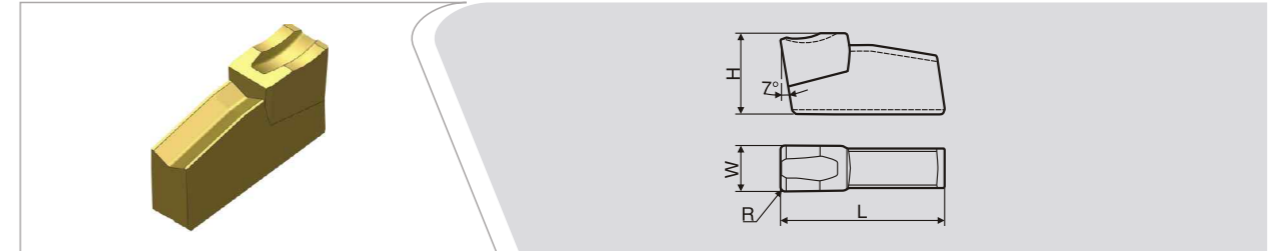

型号	尺寸				通用			CVD			金属陶瓷		
	L	W	H	R	ZP50	ZP55	CP10	CP20	CP25	CK30	T20P	T10	T20
KT 300	10	3	5.6	0.3									
400	12.8	4	7.2	0.3									
500	12.8	5	7.3	0.37									

◆常备库存 ◇预定库存

TL□□

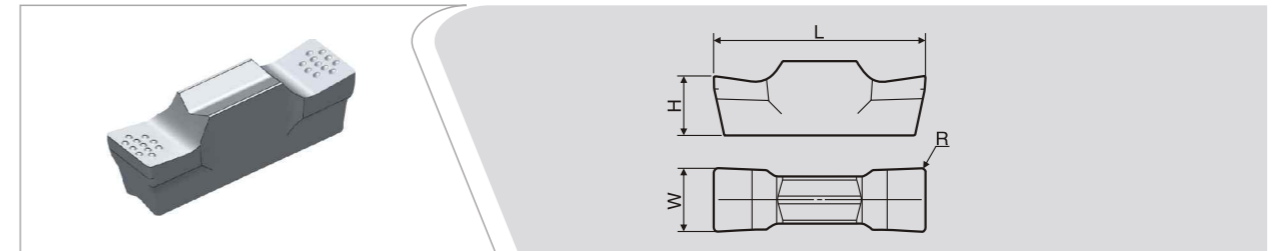

型号	尺寸				通用			CVD			金属陶瓷		
	L	W	H	R	ZP50	ZP55	CP10	CP20	CP25	CK30	T20P	T10	T20
TL 10200	10	3	2.8	0.2									
10300	10	2	2.8	0.2									

◆常备库存 ◇预定库存

A 车刀系列

B 铣刀系列

C 槽刀系列

D 螺纹刀片系列

A 车刀系列

B 铣刀系列

C 槽刀系列

D 螺纹刀片系列

NG □ □

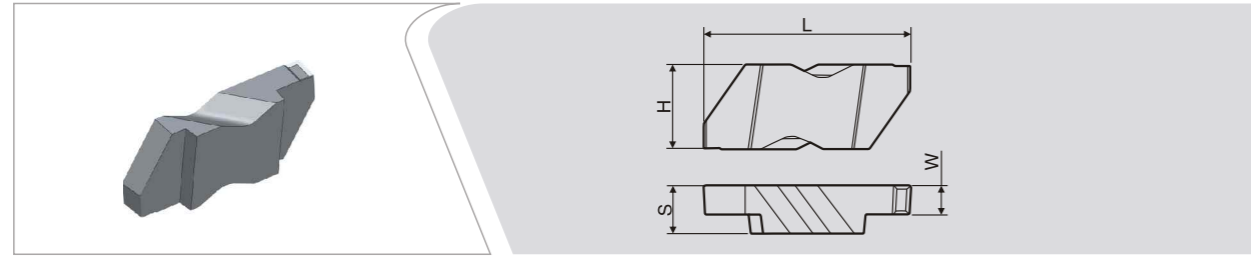

型号	尺寸				通用		CVD			金属陶瓷			
	L	W	H	S	ZP50	ZP55	CP10	CP20	CP25	CK30	T20P	T10	T20
NG 4M250R	22.8	2.7	9.3	5.3	■								
4M300R	22.8	3.2	9.3	5.3	■								

◆ 常备库存 ◇ 预定库存

ST □ □

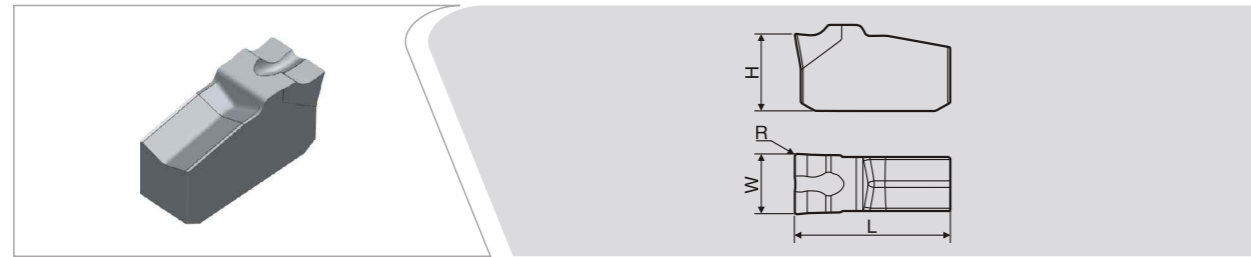

型号	尺寸				通用		CVD			金属陶瓷			
	L	W	H	R	ZP50	ZP55	CP10	CP20	CP25	CK30	T20P	T10	T20
ST 600-5E	15.7	6.05	7.8	0.2	■								

◆ 常备库存 ◇ 预定库存

NG □ □

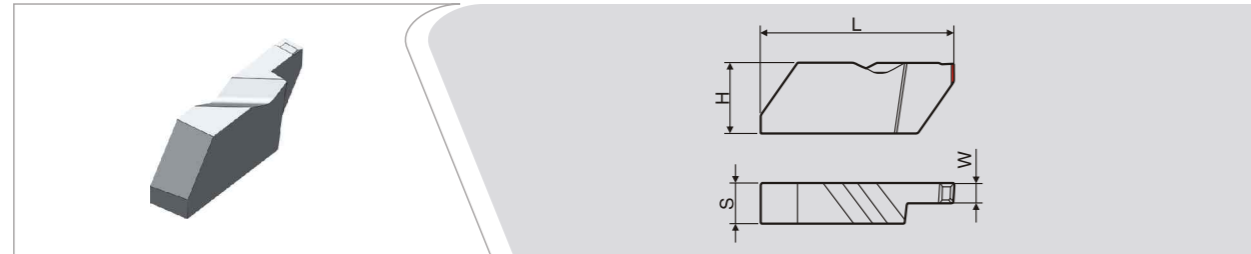

型号	尺寸				通用		CVD			金属陶瓷			
	L	W	H	S	ZP50	ZP55	CP10	CP20	CP25	CK30	T20P	T10	T20
NG 4F240R	25.5	2.6	9.3	5.3	■								

◆ 常备库存 ◇ 预定库存

VNBR □ □

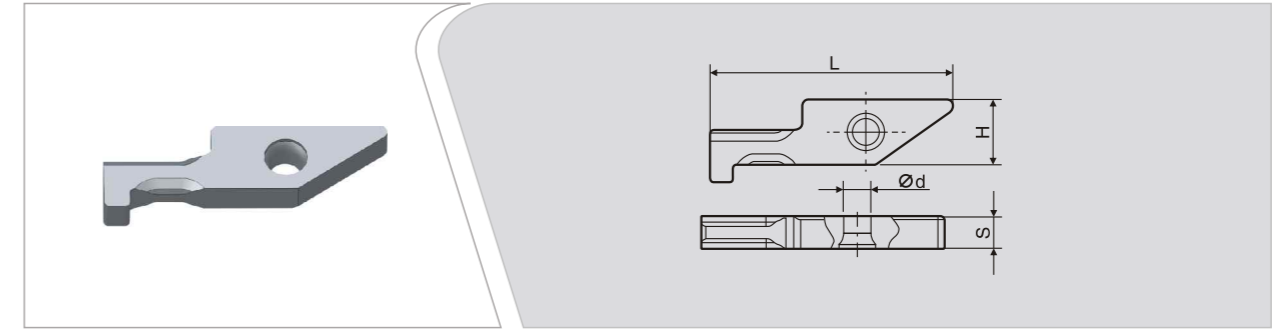

型号	尺寸				通用		CVD			金属陶瓷			
	L	S	H	φd	ZP50	ZP55	CP10	CP20	CP25	CK30	T20P	T10	T20
VNBR 0511	30.3	3.85	7.94	3.4	■								
0620	40.3	3.85	7.94	3.4	■								
0730	50.3	3.85	7.94	3.4	■								

◆ 常备库存 ◇ 预定库存

WGE □ □

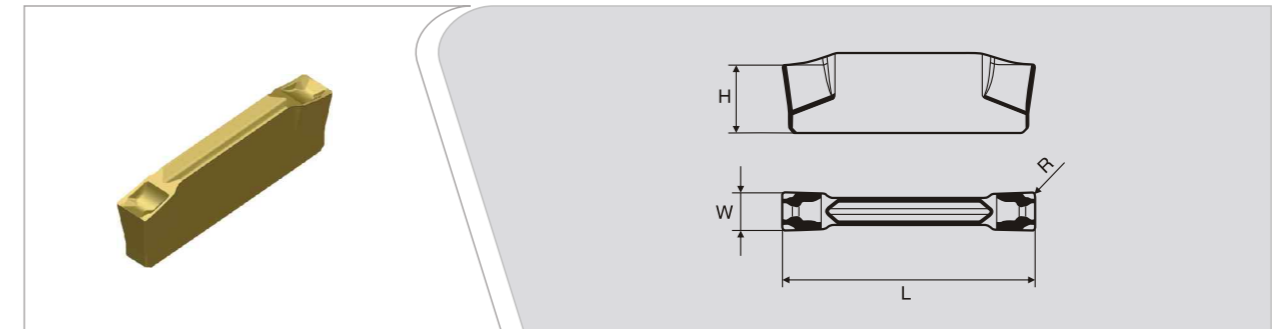

型号	尺寸				通用		CVD			金属陶瓷			
	L	W	H	R	ZP50	ZP55	CP10	CP20	CP25	CK30	T20P	T10	T20
WGE 20	20	2	4.7	0.2	■								
30	20	3	5.5	0.2	■								
40	25	4	5.7	0.2	■								
50	25	5	5.9	0.2	■								

◆ 常备库存 ◇ 预定库存

A 车刀系列

B 铣刀系列

C 槽刀系列

D 螺纹刀片系列

A 车刀系列

B 铣刀系列

C 槽刀系列

D 螺纹刀片系列

16ER/IR□□

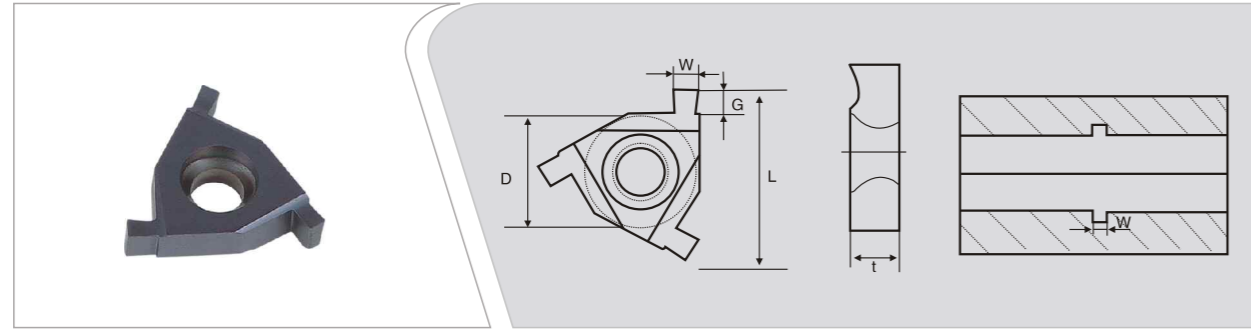

A 车刀系列

B 铣刀系列

C 槽刀系列

D 螺纹刀片系列

型号	规格尺寸(mm)					通用		CVD			金属陶瓷			
	L	W	G	d	t	ZP50	ZP55	CP10	CP20	CP25	CK30	T20P	T10	T20
08ER/IR	0.75	0.75	0.8	3/16	2.2	■	■	■	■	■	■	■	■	■
	0.80	0.80	0.8											
	0.85	0.85	0.8											
	0.90	0.90	0.8											
	1.00	1.00	0.8											
	0.80	0.80	1.2											
	11ER/IR	0.85	0.85											
0.90		0.90	1.2											
1.00		1.00	1.2											
1.10		1.10	1.2											
1.20		1.20	1.2											
1.25		1.25	1.2											
1.30		1.30	1.2											
1.40		1.40	1.2											
1.50		1.50	1.2											
2.00		2.00	1.2											
16ER/IR		0.80	0.80	1.4	3/8	3.65	■	■	■	■	■	■	■	■
	0.90	0.90	1.4											
	1.00	1.00	1.4											
	1.05	1.05	1.8											
	1.10	1.10	1.8											

更多型号可咨询，接受非标制定

◆常备库存 ◇预定库存

16ER/IR□□

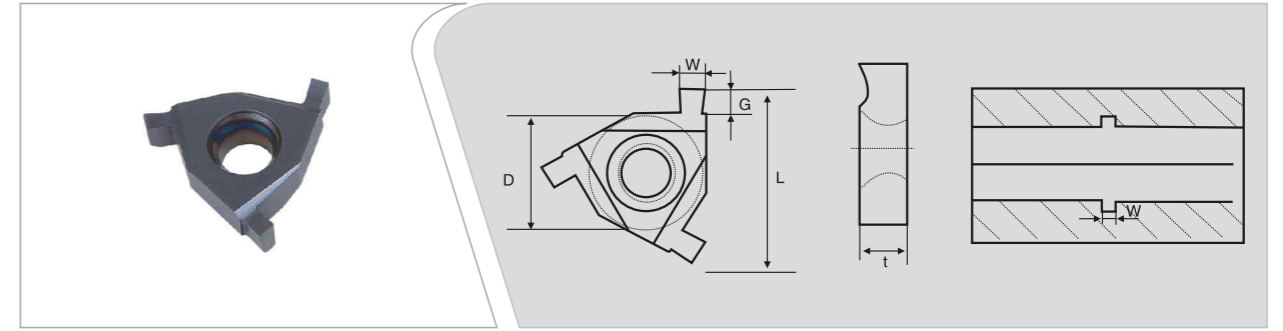

A 车刀系列

B 铣刀系列

C 槽刀系列

D 螺纹刀片系列

型号	规格尺寸(mm)					通用		CVD			金属陶瓷			
	L	W	G	d	t	ZP50	ZP55	CP10	CP20	CP25	CK30	T20P	T10	T20
16ER/IR	1.20	1.20	1.80	16	3/8	■	■	■	■	■	■	■	■	■
	1.25	1.25	1.80											
	1.30	1.30	1.80											
	1.35	1.35	1.80											
	1.40	1.40	1.80											
	1.45	1.45	1.80											
	1.50	1.50	1.80											
	1.55	1.55	2.0											
	1.60	1.60	2.0											
	1.65	1.65	2.0											
	1.70	1.70	2.0											
	1.75	1.75	2.0											
	1.80	1.80	2.0											
	1.85	1.85	2.0											
	1.90	1.90	2.0											
	2.00	2.00	2.0											
	2.05	2.05	2.2											
	2.10	2.10	2.2											
	2.15	2.15	2.2											
	2.20	2.20	2.2											
	2.25	2.25	2.2											
	2.30	2.30	2.2											
	2.40	2.40	2.2											
	2.50	2.50	2.2											
	2.55	2.55	2.0											
	2.60	2.60	2.0											
	2.70	2.70	2.0											
2.80	2.80	2.0												
2.90	2.90	2.0												
3.00	3.00	2.0												

更多型号可咨询，接受非标制定

◆常备库存 ◇预定库存

TGF32R/L□□□

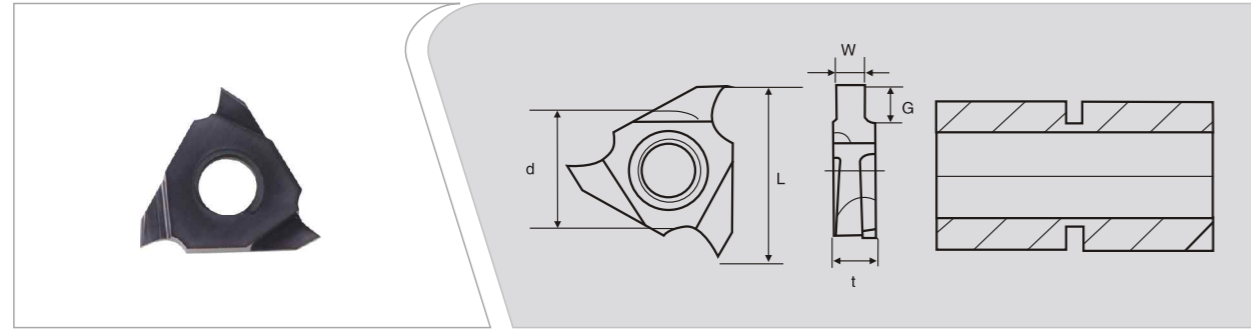

A 车刀系列

B 铣刀系列

C 槽刀系列

D 螺纹刀片系列

型号	规格尺寸(mm)					通用		CVD			金属陶瓷				
	L	W	G	d	t	ZP50	ZP55	CP10	CP20	CP25	CK30	T20P	T10	T20	
TGF32R/L 030 040 050 060 065 070 075 080 085	16	0.30	0.9	3/8	3.18	◆	◆	◆	◆	◆	◆	◆	◆	◆	◆
		0.40	1.3												
		0.50	1.3												
		0.60	1.9												
		0.65	1.9												
		0.70	1.9												
		0.75	1.9												
		0.80	1.9												
		0.85	1.9												
		090	16												
095	0.95	1.9													
100	1.00	2.3													
110	1.10	2.3													
115	1.15	2.3													
120	1.20	2.3													
125	1.25	2.3													
130	1.30	2.3													
135	1.35	2.3													
140	1.40	2.3													
145	16	1.45	2.3	3/8	3.18	◆	◆	◆	◆	◆	◆	◆	◆	◆	
150		1.50	2.3												
155		1.55	2.3												
160		1.60	2.3												
165		1.65	2.3												
170		1.70	2.3												
175		1.75	2.3												
180		1.80	2.3												

TGF更多型号可咨询，接受非标制定

◆常备库存 ◇预定库存

TGF32R/L□□□

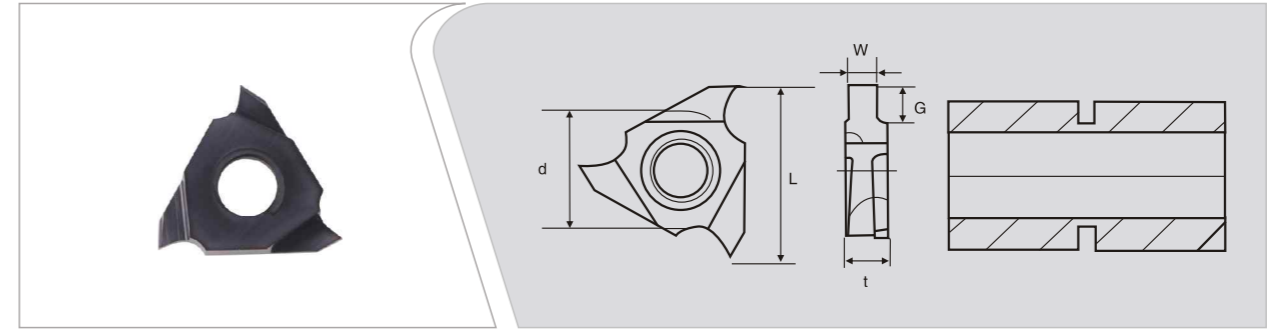

A 车刀系列

B 铣刀系列

C 槽刀系列

D 螺纹刀片系列

型号	规格尺寸(mm)					通用		CVD			金属陶瓷			
	L	W	G	d	t	ZP50	ZP55	CP10	CP20	CP25	CK30	T20P	T10	T20
TGF32R/L 190 195 200 210 215 220 225 230 240 245 250 260 270 275 280 290 300	16	1.90	2.8	3/8	3.18	◆	◆	◆	◆	◆	◆	◆	◆	◆
		1.95	2.8											
		2.00	2.8											
		2.10	2.8											
		2.15	2.8											
		2.20	2.8											
		2.25	2.8											
		2.30	2.8											
		2.40	2.8											
		2.45	2.8											
		2.50	2.8											
		2.60	2.8											
		2.70	2.8											
		2.75	2.8											
		2.80	2.8											
		2.90	2.8											
		3.00	2.8											

TGF更多型号可咨询，接受非标制定

◆常备库存 ◇预定库存

TGF32R/L□□

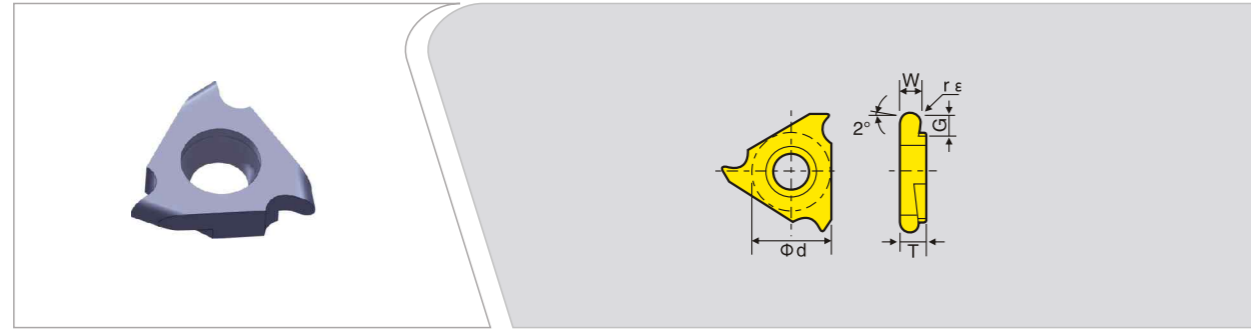

型号	规格尺寸(mm)				通用			CVD			金属陶瓷		
	D	T	W	R	ZP50	ZP55	CP10	CP20	CP25	CK30	T20P	T10	T20
TGF32R/L	100-R0.5	9.525	3.18	1.0	0.5								
	150-R0.75	9.525	3.18	1.5	0.75								
	200-R1.0	9.525	3.18	2.0	1.0								
	300-R1.5	9.525	3.18	3.0	1.5								

FC32R/L□□

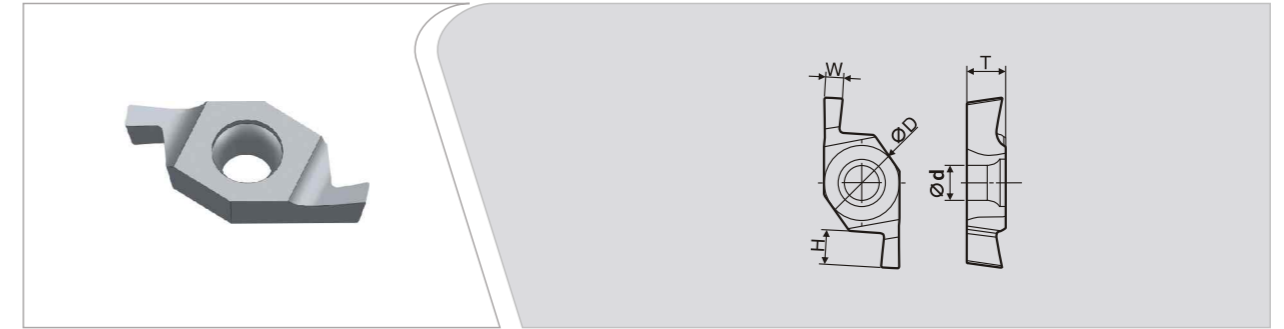

型号	规格尺寸(mm)					通用			CVD			金属陶瓷		
	ΦD	W	H	T	Φd	ZP50	ZP55	CP10	CP20	CP25	CK30	T20P	T10	T20
FC32R/L	100-2.5	9.525	1.0	2.5	4.76	4.4								
	150-3.0	9.525	1.5	3.0	4.76	4.4								
	200-2.0	9.525	2.0	2.0	4.76	4.4								
	200-2.5	9.525	2.0	2.5	4.76	4.4								
	200-3.0	9.525	2.0	3.0	4.76	4.4								
	240-2.5	9.525	2.4	2.5	4.76	4.4								
	250-2.5	9.525	2.5	2.5	4.76	4.4								
	250-3.0	9.525	2.5	3.0	4.76	4.4								
	300-3.0	9.525	3.0	3.0	4.76	4.4								

FC1604R/L□□

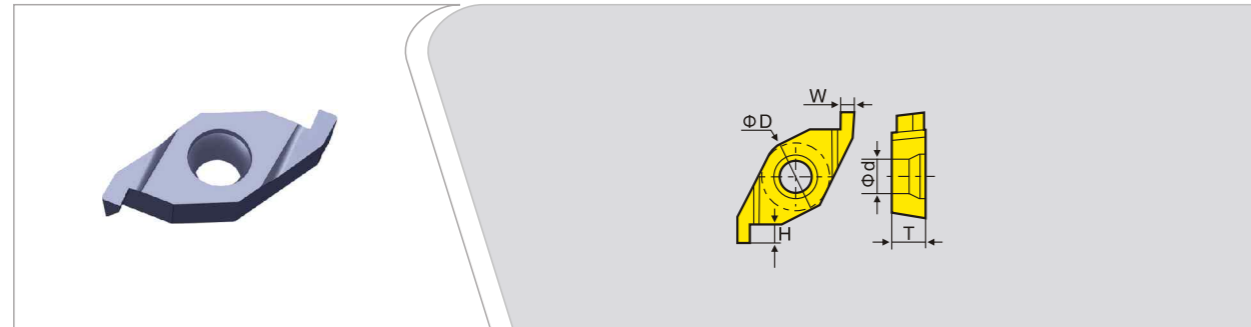

型号	规格尺寸(mm)					通用			CVD			金属陶瓷		
	ΦD	W	H	T	Φd	ZP50	ZP55	CP10	CP20	CP25	CK30	T20P	T10	T20
FC	1604R/L-1.5	9.525	1.5	1.6	4.76	4.4								
	1604R/L-2.0	9.525	2.0	1.8	4.76	4.4								
	1604R/L-2.2	9.525	2.2	2.0	4.76	4.4								
	1604R/L-2.5	9.525	2.5	2.3	4.76	4.4								
	1604R/L-2.8	9.525	2.8	2.5	4.76	4.4								
	1604R/L-3.0	9.525	3.0	2.5	4.76	4.4								

更多型号可咨询，接受非标制定

◆常备库存 ◇预定库存

FC32R/L□□

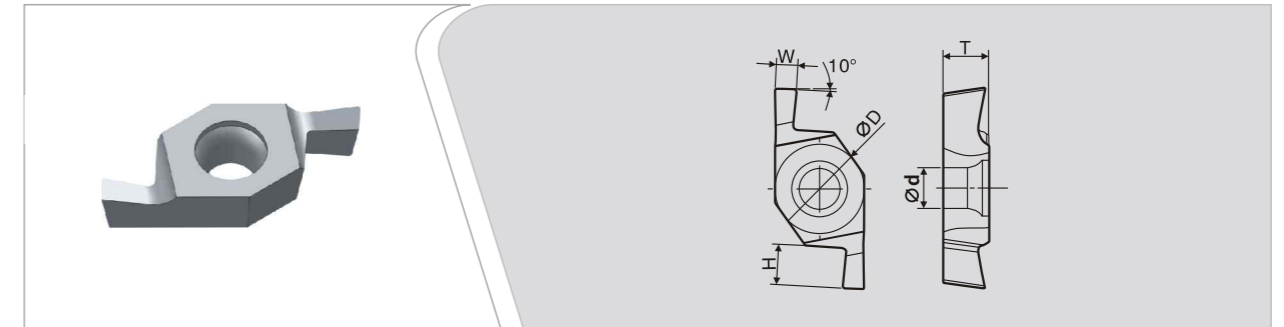

型号	规格尺寸(mm)				通用			CVD			金属陶瓷		
	ΦD	W	T	Φd	ZP50	ZP55	CP10	CP20	CP25	CK30	T20P	T10	T20
FC32R/L	150-24	9.525	1.5	4.76	4.4								
	180-24	9.525	1.8	4.76	4.4								
	190-24	9.525	1.9	4.76	4.4								
	200-24	9.525	2.0	4.76	4.4								
	240-24	9.525	2.4	4.76	4.4								
	250-24	9.525	2.5	4.76	4.4								
	300-24	9.525	3.0	4.76	4.4								

A 车刀系列

B 铣刀系列

C 槽刀系列

D 螺纹刀片系列

A 车刀系列

B 铣刀系列

C 槽刀系列

D 螺纹刀片系列

GER□□-A

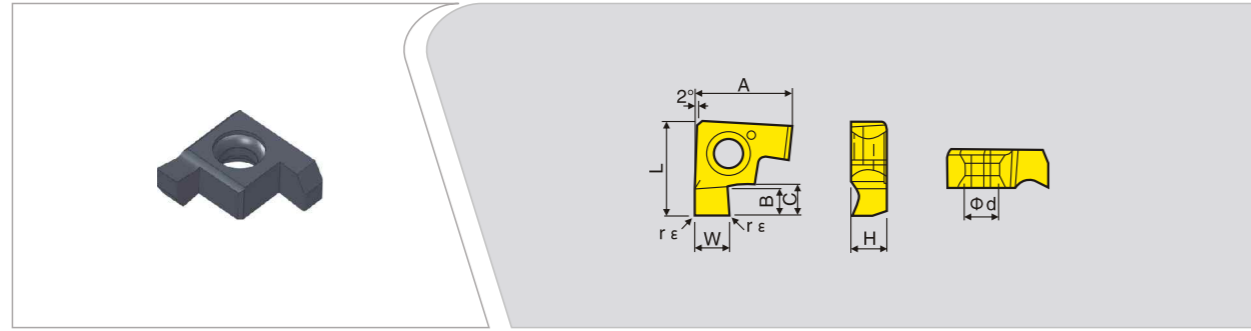

型号	规格尺寸(mm)								通用			CVD			金属陶瓷		
	W	B	C	rε	A	L	H	φd	ZP50	ZP55	CP10	CP20	CP25	CK30	T20P	T10	T20
GER 100-A	1.00	1.5	1.8	0.05	6.69	6.5	2.58	2.5									
125-A	1.25	1.5	1.8	0.05	6.69	6.5	2.58	2.5									
150-A	1.50	1.5	1.8	0.1	6.69	6.5	2.58	2.5									
200-A	2.00	1.5	1.8	0.1	6.69	6.5	2.58	2.5									

更多型号可咨询，接受非标定制

GER□□-C

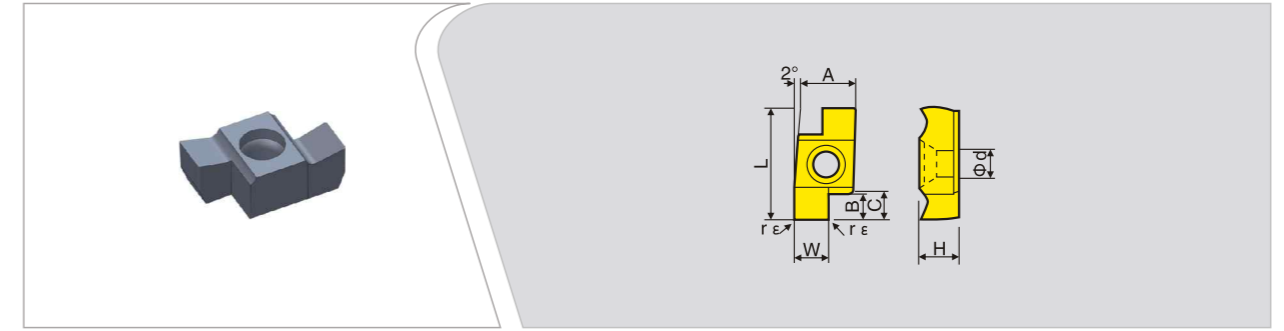

型号	规格尺寸(mm)								通用			CVD			金属陶瓷		
	W	B	C	rε	A	L	H	φd	ZP50	ZP55	CP10	CP20	CP25	CK30	T20P	T10	T20
GER 100-C	1.00	2.5	2.7	0.05	5.8	11.48	4.05	2.8									
125-C	1.25	2.5	2.7	0.05	5.8	11.48	4.05	2.8									
150-C	1.50	2.5	2.7	0.1	5.8	11.48	4.05	2.8									
175-C	1.75	2.5	2.7	0.1	5.8	11.48	4.05	2.8									
200-C	2.00	2.5	2.7	0.1	5.8	11.48	4.05	2.8									
250-C	2.50	2.5	2.7	0.2	5.8	11.48	4.05	2.8									
300-C	3.00	2.5	2.7	0.2	5.8	11.48	4.05	2.8									

更多型号可咨询，接受非标定制

GER□□-B

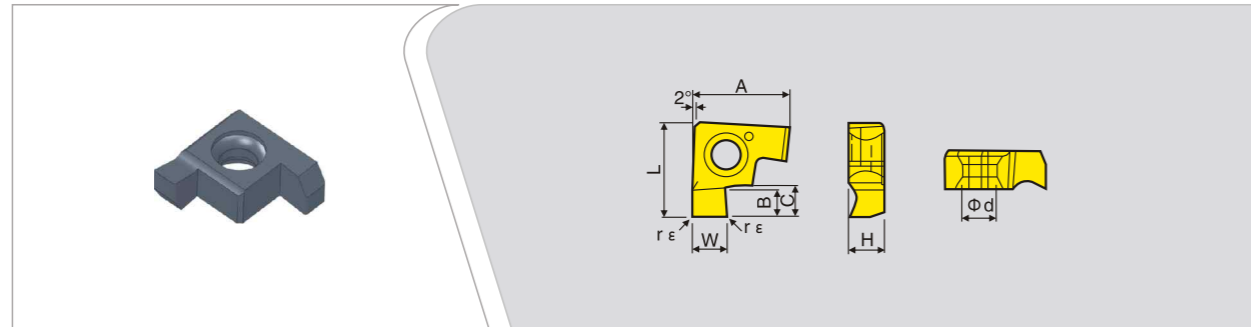

型号	规格尺寸(mm)								通用			CVD			金属陶瓷		
	W	B	C	rε	A	L	H	φd	ZP50	ZP55	CP10	CP20	CP25	CK30	T20P	T10	T20
GER 100-B	1.00	2.2	2.6	0.05	8.46	8.2	3.18	2.7									
125-B	1.25	2.2	2.6	0.05	8.46	8.2	3.18	2.7									
150-B	1.50	2.2	2.6	0.1	8.46	8.2	3.18	2.7									
200-B	2.00	2.2	2.6	0.1	8.46	8.2	3.18	2.7									
250-B	2.50	2.2	2.6	0.2	8.46	8.2	3.18	2.7									
300-B	3.00	2.2	2.6	0.2	8.46	8.2	3.18	2.7									

更多型号可咨询，接受非标定制

GER□□-D

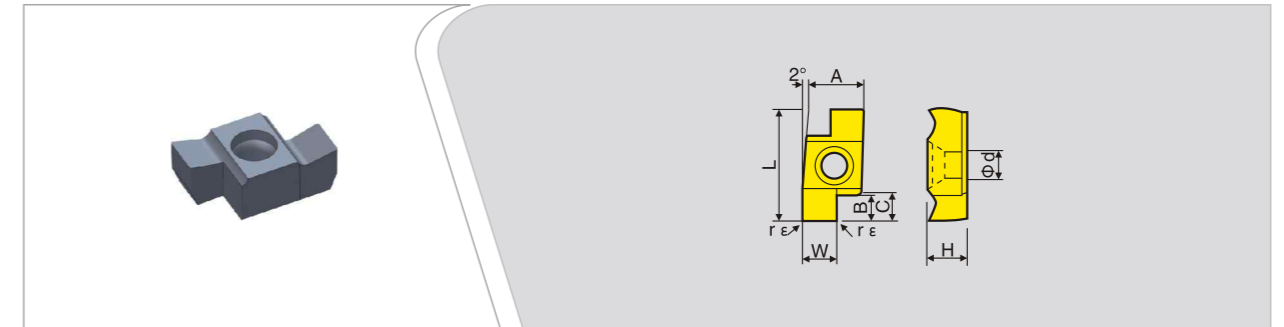

型号	规格尺寸(mm)								通用			CVD			金属陶瓷		
	W	B	C	rε	A	L	H	φd	ZP50	ZP55	CP10	CP20	CP25	CK30	T20P	T10	T20
GER 100-D	1.00	2.5	4.8	0.05	6.8	16.44	5.05	3.4									
150-D	1.50	3.0	4.8	0.10	6.8	16.44	5.05	3.4									
170-D	1.70	3.0	4.8	0.10	6.8	16.44	5.05	3.4									
200-D	2.00	3.2	4.8	0.10	6.8	16.44	5.05	3.4									
250-D	2.50	3.2	4.8	0.10	6.8	16.44	5.05	3.4									
300-D	3.00	4.5	4.8	0.20	6.8	16.44	5.05	3.4									
350-D	3.50	4.5	4.8	0.20	6.8	16.44	5.05	3.4									

更多型号可咨询，接受非标定制

GR

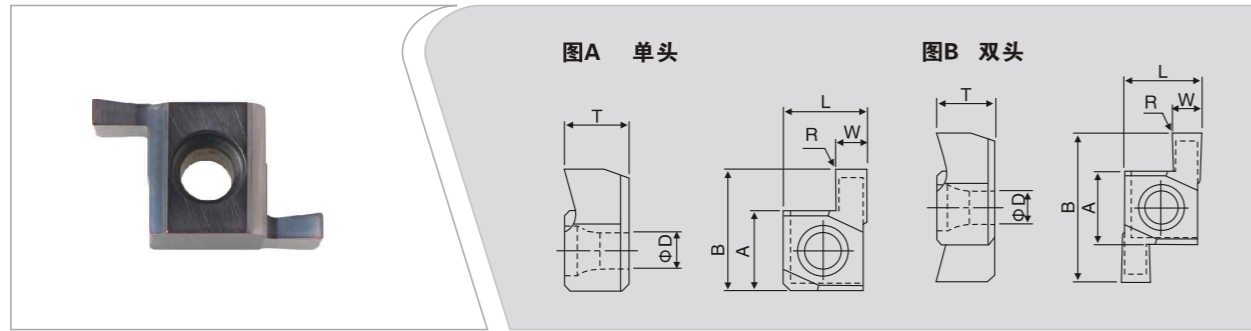

型号	尺寸								通用			CVD			金属陶瓷		
	最大切深	W	A	B	T	φD	L	R	ZP50	ZP55	CP10	CP20	CP25	CK30	T20P	T10	T20
6GR/L 100	1																
	150	1.5	4.76	6.44	2.34	2.3	5.56										
	200	2															
7GR/L 100	1																
	150	1.5	5.56	7.36	3.08	2.58	5.56										
	200	2															
8GR/L 100	1																
	150	1.5															
	200	2															
	250	2	5.56	10.16	3.87	2.58	6.15	0.2									
	300	3															
	350	3.5															
9GR/L 100	1																
	150	2															
	200	2															
	250	2.5	6.35	12.95	4.66	2.86	7.74										
	300	3															
350	3.5																

更多型号可咨询，接受非标制定

◆常备库存 ◇预定库存

泛牙型60°

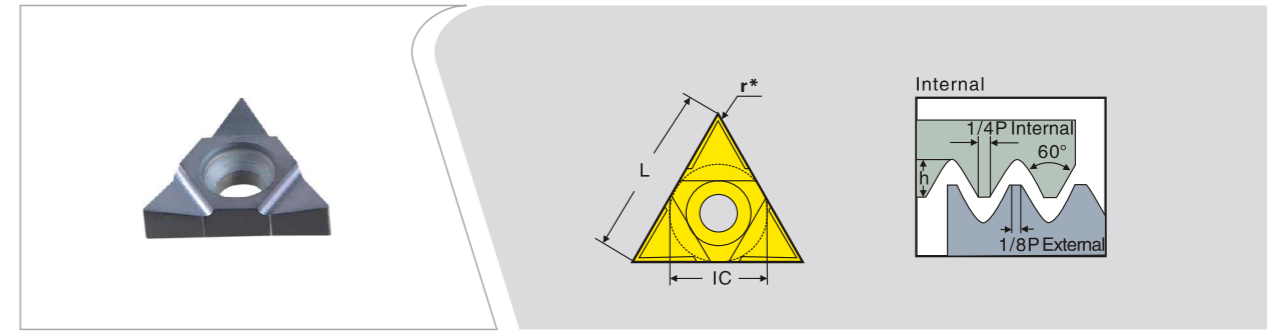

型号	螺距		刀尖R	通用			CVD			金属陶瓷		
	mm	tpi	r	ZP50	ZP55	CP10	CP20	CP25	CK30	T20P	T10	T20
11UI-60° -0520	0.5-2.0	48-12	0.04									
11UI-60° -1530	1.5-3.0	16-8	0.11									
11UI-60° -2540	2.5-4.0	10-6	0.14									
16UI-60° -1535	1.5-3.5	16-7	0.11									
16UI-60° -3560	3.5-6.0	7-4	0.24									

◆常备库存 ◇预定库存

泛牙型55°

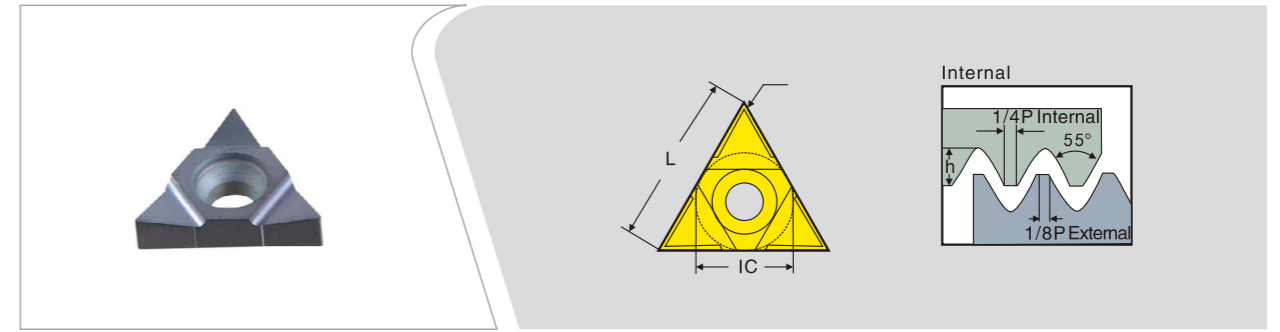

型号	螺距	刀尖R	通用			CVD			金属陶瓷		
	tpi	r	ZP50	ZP55	CP10	CP20	CP25	CK30	T20P	T10	T20
11UI-55° -16-12	16-12	0.08									
11UI-55° -11-7	11-7	0.24									
16UI-55° -16-12	16-12	0.08									
16UI-55° -11-7	11-7	0.24									
16UI-55° -6-4	6-4	0.27									

◆常备库存 ◇预定库存

A 车刀系列

B 铣刀系列

C 槽刀系列

D 螺纹刀片系列

A 车刀系列

B 铣刀系列

C 槽刀系列

D 螺纹刀片系列

16ER/16IR□□

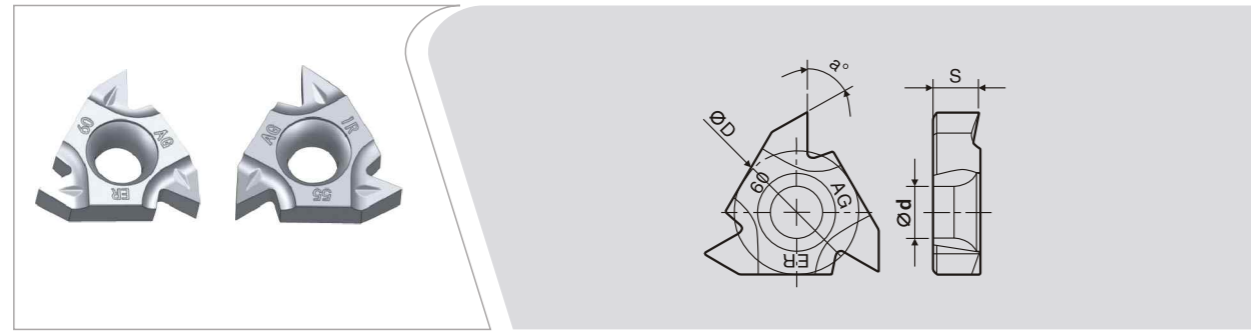

型号	尺寸				通用			CVD			金属陶瓷		
	φD	S	a°	φd	ZP50	ZP55	CP10	CP20	CP25	CK30	T20P	T10	T20
16ER AG60	9.525	3.45	60	4	■								
16IR AG60	9.525	3.45	60	4									
16ER AG55	9.525	3.45	55	4	■								
16IR AG55	9.525	3.45	55	4									

◆常备库存 ◇预定库存

16ER/16IR□□

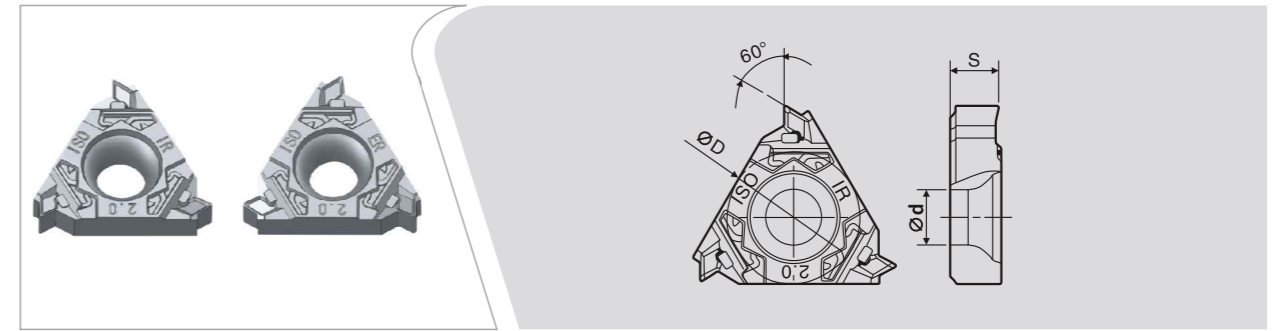

型号	尺寸				通用			CVD			金属陶瓷		
	φD	S	a°	φd	ZP50	ZP55	CP10	CP20	CP25	CK30	T20P	T10	T20
16IRM 100ISO	9.525	3.44	60	4	■								
16IRM 150ISO	9.525	3.44	60	4									
16IRM 200ISO	9.525	3.44	60	4									
16IRM 300ISO	9.525	3.44	60	4									
16ERM 100ISO	9.525	3.44	60	4	■								
16ERM 150ISO	9.525	3.44	60	4									
16ERM 200ISO	9.525	3.44	60	4									
16ERM 300ISO	9.525	3.44	60	4									

◆常备库存 ◇预定库存

16ER/16IR□□

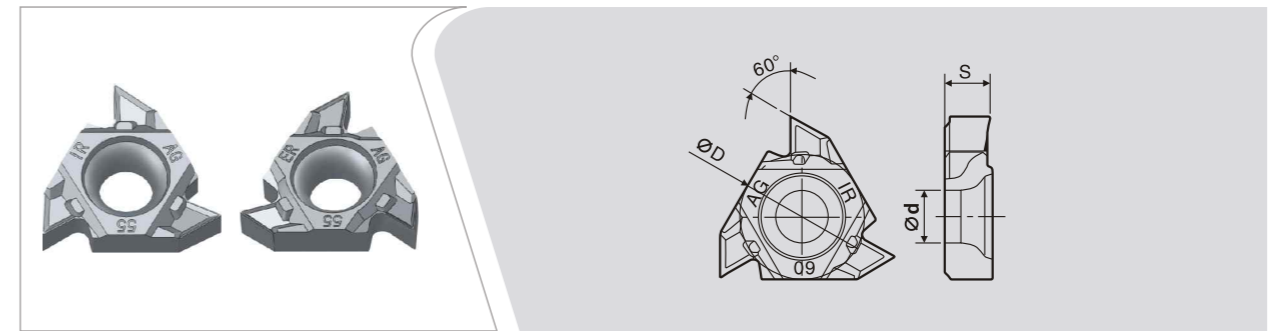

型号	尺寸				通用			CVD			金属陶瓷		
	φD	S	a°	φd	ZP50	ZP55	CP10	CP20	CP25	CK30	T20P	T10	T20
16IRM AG55	9.525	3.44	60	4	■								
16IRM G55	9.525	3.44	60	4									
11IRM A55	6.35	3.04	60	3									
16ERM AG55	9.525	3.44	60	4	■								
16ERM G55	9.525	3.44	60	4									
11ERM A55	9.525	3.44	60	4									
16IRM AG60	9.525	3.44	60	4	■								
16IRM G60	9.525	3.44	60	4									
11IRM A60	6.35	3.04	60	3									
16ERM AG60	9.525	3.44	60	4	■								
16ERM G60	9.525	3.44	60	4									
11ERM A60	9.525	3.44	60	4									

◆常备库存 ◇预定库存

16ER/16IR□□

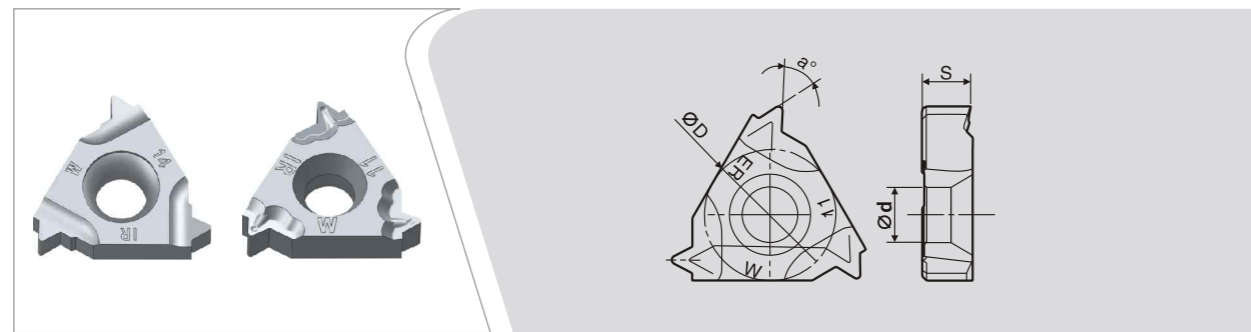

型号	尺寸				通用			CVD			金属陶瓷		
	φD	S	a°	φd	ZP50	ZP55	CP10	CP20	CP25	CK30	T20P	T10	T20
16IR 11W	9.525	3.45	55	4	■								
16IR 14W	9.525	3.45	55	4									
16ER 11W	9.525	3.45	55	4	■								
16ER 14W	9.525	3.45	55	4									
16ER 11NPT	9.525	3.45	55	4	■								
16ER 14NPT	9.525	3.45	55	4									

◆常备库存 ◇预定库存

A 车刀系列

B 铣刀系列

C 槽刀系列

D 螺纹刀片系列

A 车刀系列

B 铣刀系列

C 槽刀系列

D 螺纹刀片系列

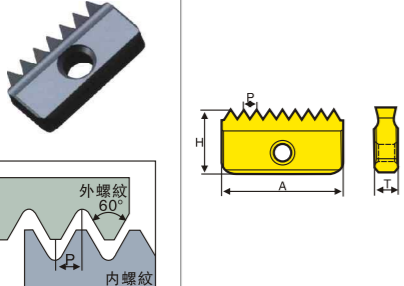
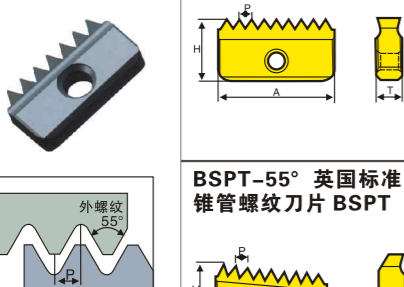
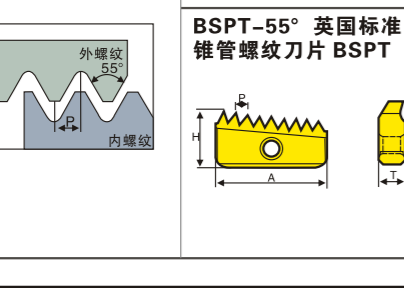
刀片外形	加工螺距 (mm)		尺寸(mm)=A				
			12	14	21	30	40
ISO标准型螺纹刀片 ISO 	0.5	外Ext.					
	0.5	内Int.	*12 I 0.5 ISO	14 I 0.5 ISO			
	0.75	外Ext.		14 E 0.75 ISO			
	0.75	内Int.	*12 I 0.75 ISO	14 I 0.75 ISO			
	1.0	外Ext.		14 E 1.0 ISO	21 E 1.0 ISO		
	1.0	内Int.	*12 I 1.0 ISO	14 I 1.0 ISO	21 I 1.0 ISO		
	1.25	外Ext.		14 E 1.25 ISO			
	1.25	内Int.	*12 I 1.25 ISO	14 I 1.25 ISO			
	1.5	外Ext.		14 E 1.5 ISO	21 E 1.5 ISO	30 E 1.5 ISO	40 E 1.5 ISO
	1.5	内Int.	*12 I 1.5 ISO	14 I 1.5 ISO	21 I 1.5 ISO	30 I 1.5 ISO	40 I 1.5 ISO
	1.75	外Ext.		14 E 1.75 ISO			
	1.75	内Int.		14 I 1.75 ISO	21 I 1.75 ISO		
	2.0	外Ext.		14 E 2.0 ISO	21 E 2.0 ISO	30 E 2.0 ISO	40 E 2.0 ISO
	2.0	内Int.		14 I 2.0 ISO	21 I 2.0 ISO	30 I 2.0 ISO	40 I 2.0 ISO
	2.5	外Ext.		14 E 2.5 ISO	21 E 2.5 ISO		
	2.5	内Int.		14 I 2.5 ISO	21 I 2.5 ISO		
	3.0	外Ext.			21 E 3.0 ISO	30 E 3.0 ISO	40 E 3.0 ISO
	3.0	内Int.			21 I 3.0 ISO	30 I 3.0 ISO	40 I 3.0 ISO
	3.5	外Ext.				30 E 3.5 ISO	
	3.5	内Int.			21 I 3.5 ISO	30 I 3.5 ISO	40 I 3.5 ISO
	4.0	外Ext.				30 E 4.0 ISO	40 E 4.0 ISO
	4.0	内Int.				30 I 4.0 ISO	40 I 4.0 ISO
	4.5	外Ext.					
	4.5	内Int.				30 I 4.5 ISO	40 I 4.5 ISO
5.0	外Ext.					40 E 5.0 ISO	
5.0	内Int.				30 I 5.0 ISO	40 I 5.0 ISO	
5.5	外Ext.						
5.5	内Int.					40 I 5.5 ISO	
6.0	外Ext.					40 E 6.0 ISO	
6.0	内Int.						
W-55° 英国惠氏螺纹刀片 BSW,BSF,BSP 	24			14-24 W			
	20			14-20 W	21-20 W		
	19		*12-19 W	14-19 W	21-19 W		
	16			14-16 W	21-16 W	30-16 W	
	14			14-14 W	21-14 W	30-14 W	
	11			14-11 W	21-11 W	30-11 W	40-11 W
	8						40-8 W
	BSPT-55° 英国标准锥管螺纹刀片 BSPT 	19		12-19 BSPT	14-19 BSPT		
14				14-14 BSPT	21-14 BSPT		
11					21-11 BSPT	30-11 BSPT	40-11 BSPT
H			6.3	7.5	12	16	20
T			2.9	3.1	4.7	5.5	6.3

带*的刀片只有单面刃

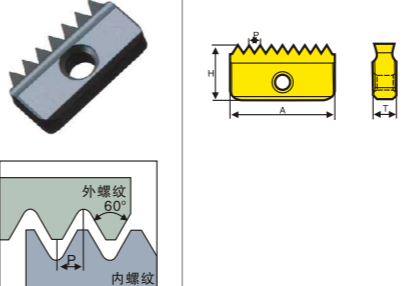
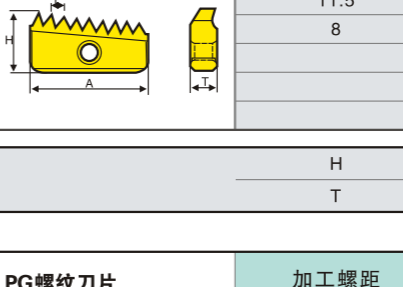
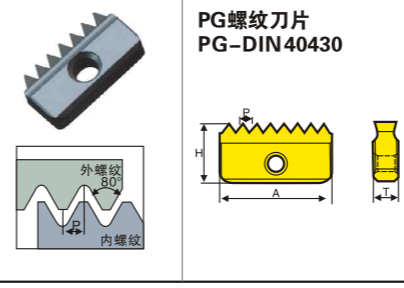
刀片外形	加工螺距 (mm)		尺寸(mm)=A				
			12	14	21	30	40
UN-60° 美制统一标准型螺纹刀片 UN,UNC,UNF,UNEF,UNS 	32	外Ext.		14 E 32 UN			
	32	内Int.	*12 I 32 UN	14 I 32 UN			
	28	外Ext.		14 E 28 UN			
	28	内Int.	*12 I 28 UN	14 I 28 UN			
	27	外Ext.					
	27	内Int.		14 I 27 UN			
	24	外Ext.		14 E 24 UN	21 E 24 UN		
	24	内Int.	*12 I 24 UN	14 I 24 UN	21 I 24 UN		
	20	外Ext.		14 E 20 UN	21 E 20 UN	30 E 20 UN	
	20	内Int.	*12 I 20 UN	14 I 20 UN	21 I 20 UN	30 I 20 UN	
	18	外Ext.		14 E 18 UN	21 E 18 UN	30 E 18 UN	
	18	内Int.	*12 I 18 UN	14 I 18 UN	21 I 18 UN	30 I 18 UN	
	16	外Ext.		14 E 16 UN	21 E 16 UN	30 E 16 UN	40 E 16 UN
	16	内Int.	*12 I 16 UN	14 I 16 UN	21 I 16 UN	30 I 16 UN	40 I 16 UN
	14	外Ext.		14 E 14 UN	21 E 14 UN	30 E 14 UN	40 E 14 UN
	14	内Int.		14 I 14 UN	21 I 14 UN	30 I 14 UN	40 I 14 UN
	12	外Ext.		14 E 12 UN	21 E 12 UN	30 E 12 UN	40 E 12 UN
	12	内Int.		14 I 12 UN	21 I 12 UN	30 I 12 UN	40 I 12 UN
	11	外Ext.					
	11	内Int.		14 I 11 UN			
	10	外Ext.			21 E 10 UN	30 E 10 UN	40 E 10 UN
	10	内Int.		14 I 10 UN	21 I 10 UN	30 I 10 UN	40 I 10 UN
	8	外Ext.				30 E 8 UN	40 E 8 UN
	8	内Int.			21 I 8 UN	30 I 8 UN	40 I 8 UN
7	外Ext.						
7	内Int.			21 I 7 UN			
6	外Ext.				30 E 6 UN	40 E 6 UN	
6	内Int.				30 I 6 UN	40 I 6 UN	
5	外Ext.						
5	内Int.				30 I 5 UN		
4.5	外Ext.						
4.5	内Int.					40 I 4.5 UN	
4	外Ext.						
4	内Int.					40 I 4 UN	
NPT-60° 美国标准锥管螺纹刀片 NPT 	18		12-18 NPT	14-18 NPT			
	14			14-14 NPT	21-14 NPT		
	11.5						
	8				21-11.5 NPT	30-11.5 NPT	40-11.5 NPT
H			6.3	7.5	12	16	20
T			2.9	3.1	4.7	5.5	6.3
PG螺纹刀片 PG-DIN40430 	加工螺距 Pitch (tpi)		尺寸Dimensions(mm)=A				
			14	21	30		
	18		14-18 PG (PG 9,11,13.5,16)	21-18 PG (PG 16)			
	16			21-16 PG (PG 21,29,36,42,48)	30-16 PG (PG 36,42,48)		
H			7.5	12	16		
T			3.1	4.7	5.5		

带*的刀片只有单面刃