

PRODUCT CATALOGUE 2023



**INNOVATING BEYOND
PIONEERING AHEAD**

-  86-0576-86970099
-  echo@wencerl.com
-  www.wencerl.com
-  Qianyangxia Village, Wenqiao Town, Wenling City, Zhejiang Province, the PRC



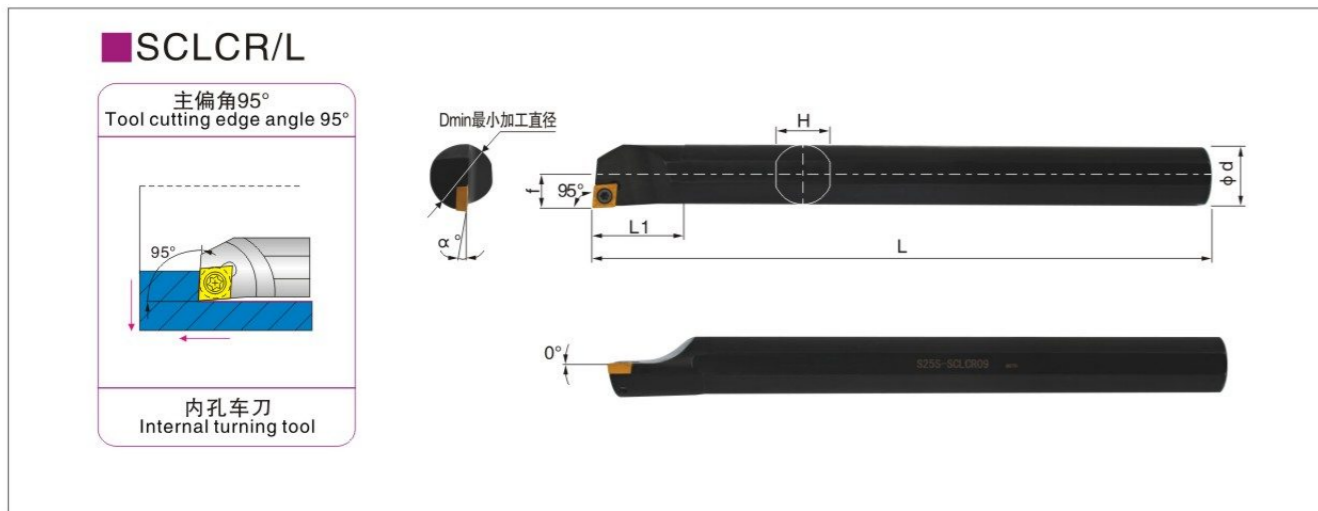

型号 Type	刀片 Blade	规格 Specification							螺丝 Screw	扳手 Wrench		
		φ Dmin	φ d	f	L	L1	H	α°				
S06H-SCLCR/L06	CC□□0602□□	8.5	6	4.4	100	12	5.4	15°	M2.5 × 5	T8		
S07K-SCLCR/L06		8.5	7	4.4	125	14	6	15°				
S08K-SCLCR/L06		10	8	5	125	14	7	15°				
S10K-SCLCR/L06		12	10	6	125	14	9	13°				
S12M-SCLCR/L06		14	12	7	150	25	11	10°				
S14N-SCLCR/L06		16	14	8	160	18	13	10°				
S16Q-SCLCR/L06	CC□□09T3□□	20	16	11	180	32	15	8°	M2.5 × 6	T8		
S12M-SCLCR/L09		15	12	7.5	150	25	11	12°				
S14N-SCLCR/L09		16	14	8.5	160	25	13	12°				
S16Q-SCLCR/L09		18	16	9.5	180	32.5	15	12°				
S18Q-SCLCR/L09		20	18	10.5	180	25	17	8°				
S20R-SCLCR/L09		23	20	11.5	200	38	18	8°				
S25S-SCLCR/L09	CC□□1204□□	28	25	14	250	45	23	6°	M4 × 8	T15		
S32T-SCLCR/L09		34	32	17.5	300	45	30	4°				
S16Q-SCLCR/L12		18	16	9.5	180	30	15	10°			M5 × 10	T20
S20R-SCLCR/L12		23	20	12	200	35	19	10°				
S25S-SCLCR/L12		29	25	14.5	250	45	23	6°				
S32T-SCLCR/L12		37	32	18.5	300	50	30	10°				
S40T-SCLCR/L12	44	40	22	300	60	37	8°					

▲更多型号可咨询，可接受高要求非标定制

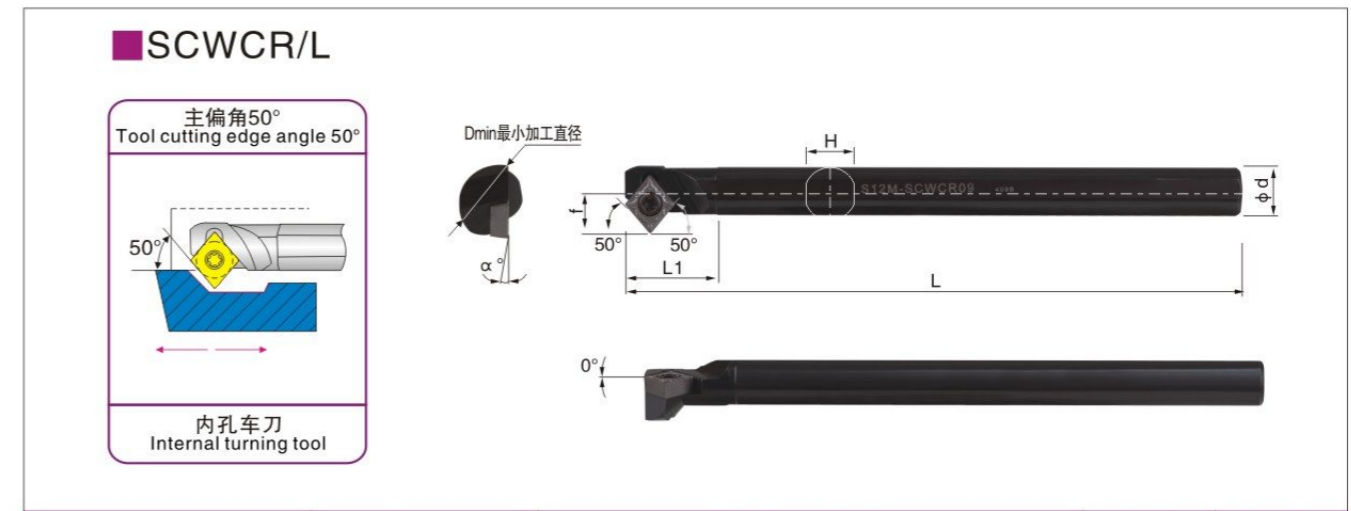

型号 Type	刀片 Blade	规格 Specification							螺丝 Screw	扳手 Wrench
		φ Dmin	φ d	f	L	L1	H	α°		
S08K-SCWCR/L06	CC□□0602□□	12	8	7	125	14	7	13°	M2.5 × 6	T8
S10K-SCWCR/L06		14	10	8	125	14	9	13°		
S12M-SCWCR/L06		16	12	9	150	16	11	10°		
S12M-SCWCR/L09	CC□□09T3□□	17	12	9.5	150	18	11	10°	M4 × 8	T15
S16Q-SCWCR/L09		21	16	11.5	180	20	14.8	10°		
S20R-SCWCR/L09		25	20	13.5	200	22	18.4	8°		

▲更多型号可咨询，可接受高要求非标定制

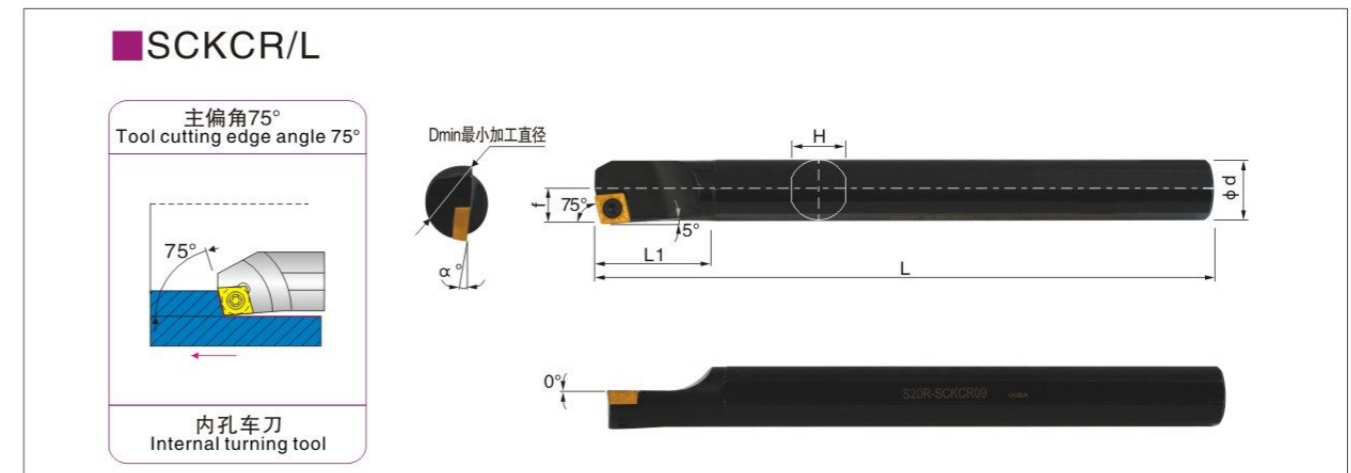

型号 Type	刀片 Blade	规格 Specification							螺丝 Screw	扳手 Wrench
		φ Dmin	φ d	f	L	L1	H	α°		
S08K-SCKCR/L06	CC□□0602□□	10.5	8	5.5	125	20	7	13°	M2.5 × 6	T8
S10K-SCKCR/L06		12	10	6	125	22	9	12°		
S12M-SCKCR/L06		14	12	7	150	23	11	10°		
S12M-SCKCR/L09	CC□□09T3□□	15	12	8	150	30	11	12°	M4 × 8	T15
S14N-SCKCR/L09		16	14	8	160	30	13	10°		
S16Q-SCKCR/L09		19	16	9.5	180	30	15	10°		
S18Q-SCKCR/L09		21	18	10.5	180	35	17	8°		
S16Q-SCKCR/L12	CC□□1204□□	18	16	9.5	180	30	15	10°	M5 × 10	T20
S20R-SCKCR/L12		23	20	12	200	40	19	10°		
S20R-SCKCR/L09	CC□□09T3□□	23	20	11.5	200	35	19	8°	M4 × 8	T15
S25S-SCKCR/L09		28	25	14	250	40	24	6°		

▲更多型号可咨询，可接受高要求非标定制

SCZCR/L

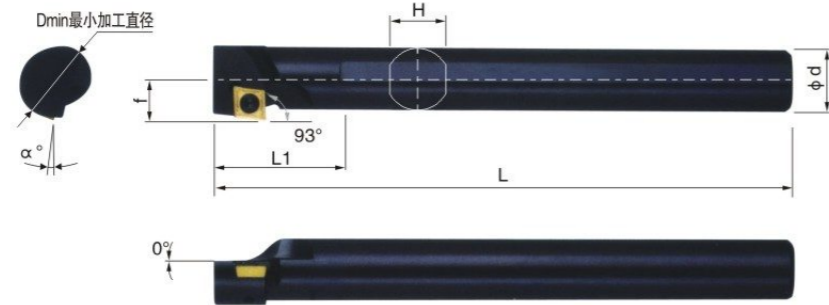
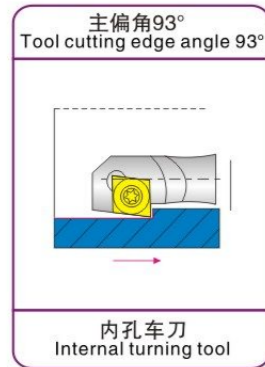

型号 Type	刀片 Blade	规格 Specification							螺丝 Screw	扳手 Wrench
		φ Dmin	φ d	f	L	L1	H	α°		
S08K-SCZCR/L06	CC□□0602□□	12	8	6.5	125	25	7	13°	M2.5 × 6	T8
S10K-SCZCR/L06		14	10	7.5	125	27	9	12°		
S12M-SCZCR/L06		16	12	8.5	150	30	11	10°		
S16Q-SCZCR/L06		20	16	10.5	180	35	15	8°		
S12M-SCZCR/L09	CC□□09T3□□	17	12	10	150	30	11	12°	M4 × 8	T15
S16Q-SCZCR/L09		21	16	11.5	180	35	15	10°		
S20R-SCZCR/L09		25	20	13.5	200	40	19	8°		
S25S-SCZCR/L09		30	25	16	250	42	24	6°		

▲更多型号可咨询, 可接受高要求非标定制

SCKCR/L 75°

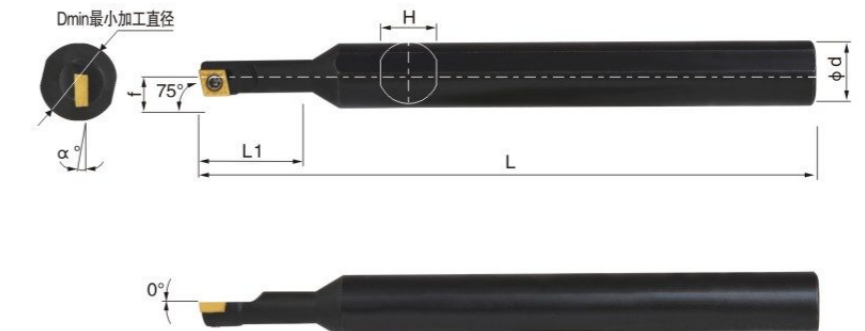
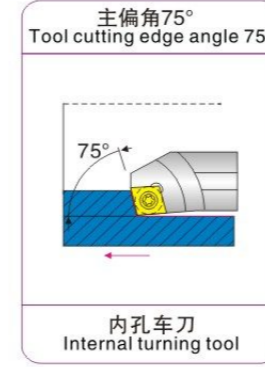

型号 Type	刀片 Blade	规格 Specification							螺丝 Screw	扳手 Wrench
		φ Dmin	φ d	L	L1	H	f	α°		
S07M-SCKCR/L06-A16	CC□□0602□□	9	16	150	25	15	4.9	15°	M2.5 × 5	T8
S08M-SCKCR/L06-A16		10	16	150	28	15	5.5	13°		
S10M-SCKCR/L06-A16		12	16	150	30	15	6	12°	M2.5 × 6	
S12M-SCKCR/L06-A16		14	16	150	35	15	7	10°		

▲更多型号可咨询, 可接受高要求非标定制

SCLCR/L 95°

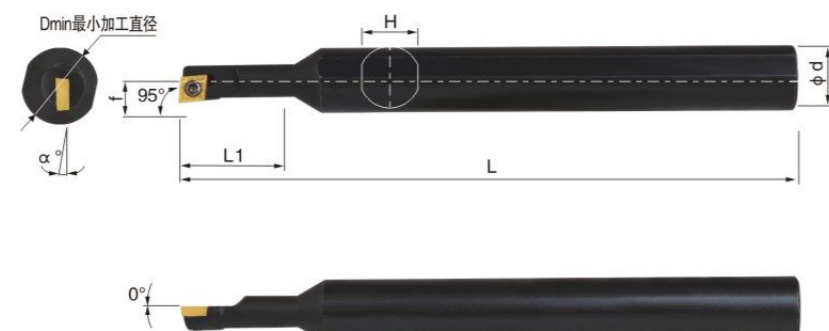
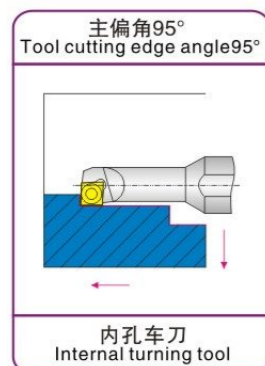

型号 Type	刀片 Blade	规格 Specification							螺丝 Screw	扳手 Wrench
		φ Dmin	φ d	L	L1	H	f	α°		
S07M-SCLCR/L06-A16	CC□□0602□□	9	16	150	25	15	4.9	15°	M2.5 × 5	T8
S08M-SCLCR/L06-A16		10	16	150	28	15	5.5	13°		
S10M-SCLCR/L06-A16		12	16	150	30	15	6	12°	M2.5 × 6	
S12M-SCLCR/L06-A16		14	16	150	35	15	7	10°		

▲更多型号可咨询, 可接受高要求非标定制

SDUCR/L

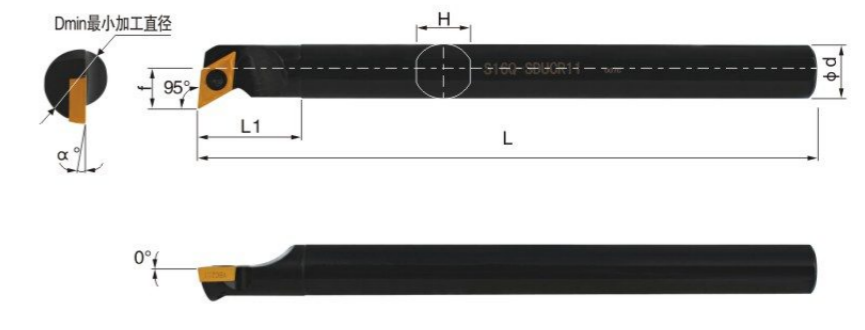
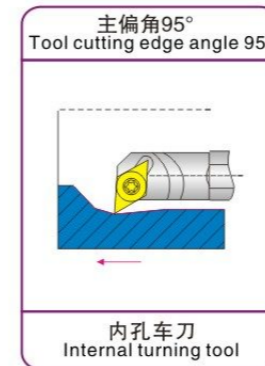

型号 Type	刀片 Blade	规格 Specification							螺丝 Screw	扳手 Wrench
		φ Dmin	φ d	f	L	L1	H	α°		
S08K-SDUCR/L07	DC□□0702□□	13	8	7	125	15	7	13°	M2.5 × 6	T8
S10K-SDUCR/L07		15	10	8	125	25	9	10°		
S12M-SDUCR/L07		17	12	9	150	28	11	8°		
S14N-SDUCR/L07		17	14	9	160	28	13	8°		
S16Q-SDUCR/L07		21	16	11	180	30	15	6°		
S16Q-SDUCR/L11	DC□□11T3□□	21	16	11	180	30	15	6°	M4 × 8	T15
S18Q-SDUCR/L11		24	18	13	180	40	17	6°		
S20R-SDUCR/L11		28	20	13	200	40	19	6°		
S25S-SDUCR/L11		35	25	16	250	40	24	4°		
S32T-SDUCR/L11		42	32	20	300	45	30	4°		

▲更多型号可咨询, 可接受高要求非标定制

SDQCR/L

主偏角107.5°
Tool cutting edge angle 107.5°

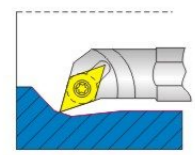

内孔车刀
Internal turning tool

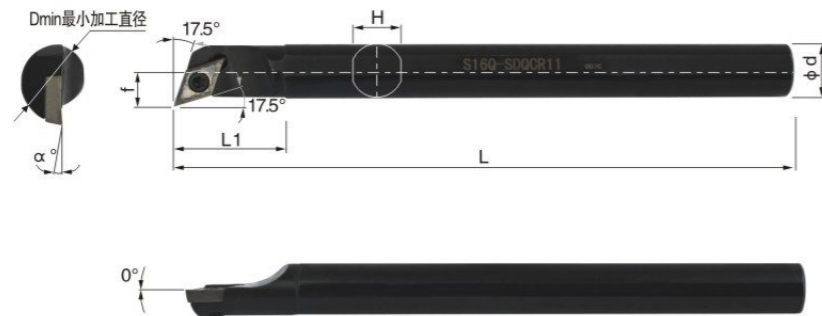

型号 Type	刀片 Blade	规格 Specification							螺丝 Screw	扳手 Wrench
		φ Dmin	φ d	f	L	L1	H	α°		
S08K-SDQCR/L07	DC□□0702□□	12	8	7	125	23	7	13°	M2.5 × 6	T8
S10K-SDQCR/L07		13	10	7	125	23	9	10°		
S12M-SDQCR/L07		16	12	9	150	30	11	8°		
S14N-SDQCR/L07		17	14	9	160	30	13	8°		
S16Q-SDQCR/L07		20	16	10.5	180	30	15	6°		
S16Q-SDQCR/L11	DC□□11T3□□	20	16	10.5	180	30	15	6°	M4 × 8	T15
S20R-SDQCR/L11		23	20	13	200	39	19	6°		
S25S-SDQCR/L11		30	25	16	250	40	24	4°		
S32T-SDQCR/L11		38	32	20	300	43	30	4°		

▲更多型号可咨询，可接受高要求非标定制

SDWCR/L

主偏角62.5°
Tool cutting edge angle 62.5°

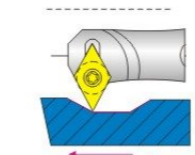

内孔车刀
Internal turning tool

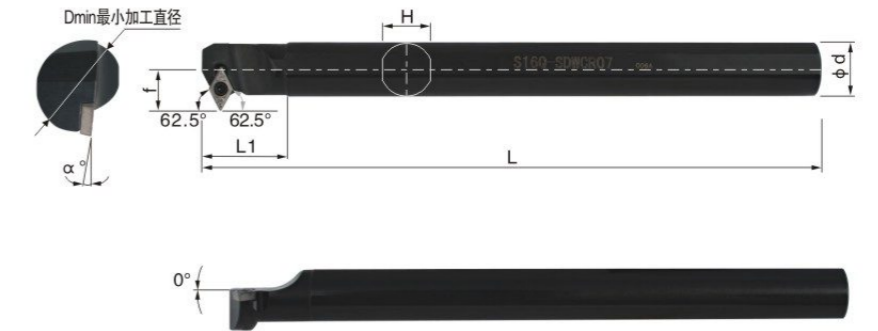

型号 Type	刀片 Blade	规格 Specification							螺丝 Screw	扳手 Wrench
		φ Dmin	φ d	f	L	L1	H	α°		
S10K-SDWCR/L07	DC□□0702□□	16	10	10	125	20	9	10°	M2.5 × 6	T8
S12M-SDWCR/L07		19	12	10.5	150	28	11	10°		
S14N-SDWCR/L07		20	14	11.5	160	30	13	10°		
S16Q-SDWCR/L07		23	16	12.5	180	30	15	8°		
S20R-SDWCR/L07		26	20	14.5	200	30	19	6°		
S16Q-SDWCR/L11	DC□□11T3□□	24	16	15	180	25	15	8°	M4 × 8	T15
S20R-SDWCR/L11		26	20	14.5	200	40	19	6°		
S25S-SDWCR/L11		32	25	17	250	45	24	4°		
S32T-SDWCR/L11		38	32	20	300	50	30	2°		

▲更多型号可咨询，可接受高要求非标定制

SDZCR/L

主偏角93°
Tool cutting edge angle 93°

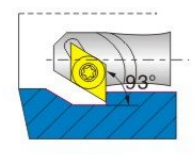

内孔车刀
Internal turning tool

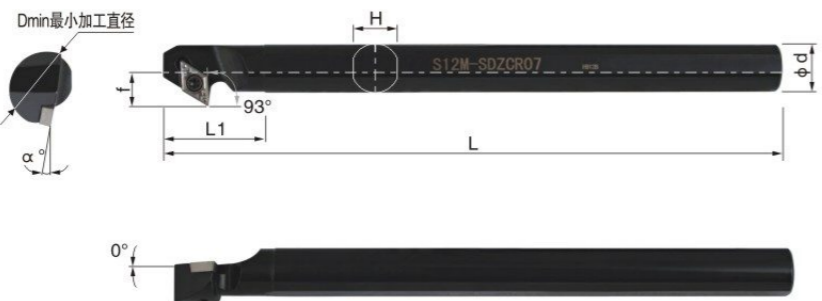

型号 Type	刀片 Blade	规格 Specification							螺丝 Screw	扳手 Wrench
		φ Dmin	φ d	f	L	L1	H	α°		
S10K-SDZCR/L07	DC□□0702□□	15	10	8.5	125	28	9	12°	M2.5 × 6	T8
S12M-SDZCR/L07		18	12	9.5	150	30	11	10°		
S16Q-SDZCR/L07		22	16	11.5	180	30	15	8°		
S16Q-SDZCR/L11	DC□□11T3□□	23	16	13.3	180	35	15	10°	M4 × 8	T15
S20R-SDZCR/L11		27	20	14.5	200	40	19	8°		
S25S-SDZCR/L11		32	25	17	250	45	24	6°		
S32T-SDZCR/L11		38	32	20.5	300	50	30	4°		

▲更多型号可咨询，可接受高要求非标定制

SDXCR/L

主偏角95°
Tool cutting edge angle 95°

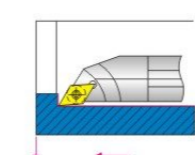

内孔车刀
Internal turning tool

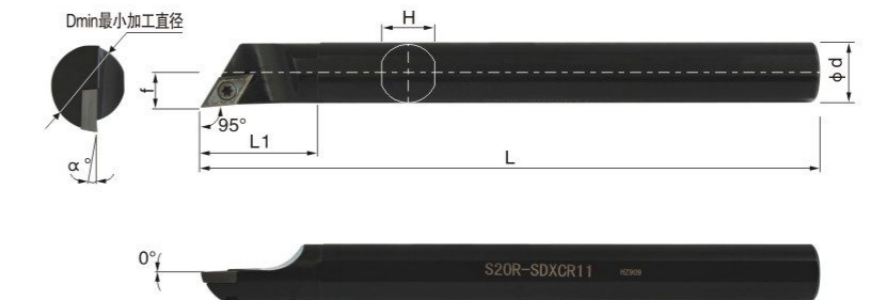

型号 Type	刀片 Blade	规格 Specification							螺丝 Screw	扳手 Wrench
		φ Dmin	φ d	f	L	L1	H	α°		
S08K-SDXCR/L07	DC□□0702□□	10	8	5.5	125	20	7	12°	M2.5 × 6	T8
S10K-SDXCR/L07		13	10	7	125	25	9	10°		
S12M-SDXCR/L07		16	12	9	150	30	11	8°		
S16Q-SDXCR/L07		20	16	11	180	30	15	6°		
S16Q-SDXCR/L11		DC□□11T3□□	19	16	9.5	180	35	15		
S20R-SDXCR/L11	25		20	13	200	40	19	6°		
S25S-SDXCR/L11	32		25	17	250	40	24	4°		

▲更多型号可咨询，可接受高要求非标定制

STUBR/L

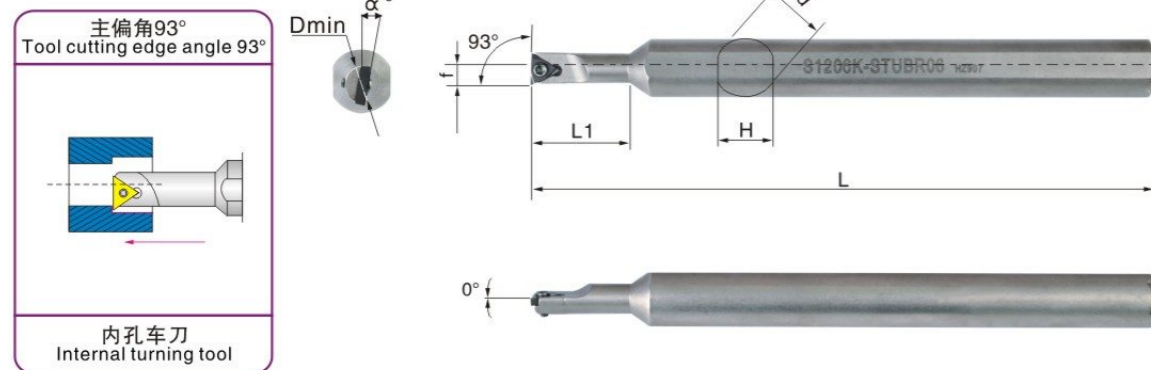

型号 Type	刀片 Blade	规格 Specification							螺丝 Screw	扳手 Wrench
		ϕ Dmin	ϕ d	f	L	L1	H	α°		
S06H-STUBR/L06	TBGT060102	7	6	4	100	15	5.4	12°	M2.2 x 5	T6
S0806J-STUBR/L06		7	8	3.5	110	20	7	12°		
S1006K-STUBR/L06		7	10	3.5	125	20	9	12°		
S1207K-STUBR/L06		8	12	4	125	25	11	12°		
S1606K-STUBR/L06		7	16	4	125	20	15	12°		
S1607M-STUBR/L06		8	16	4	150	25	15	12°		

▲更多型号可咨询，可接受高要求非标定制

STU□R/L 93°

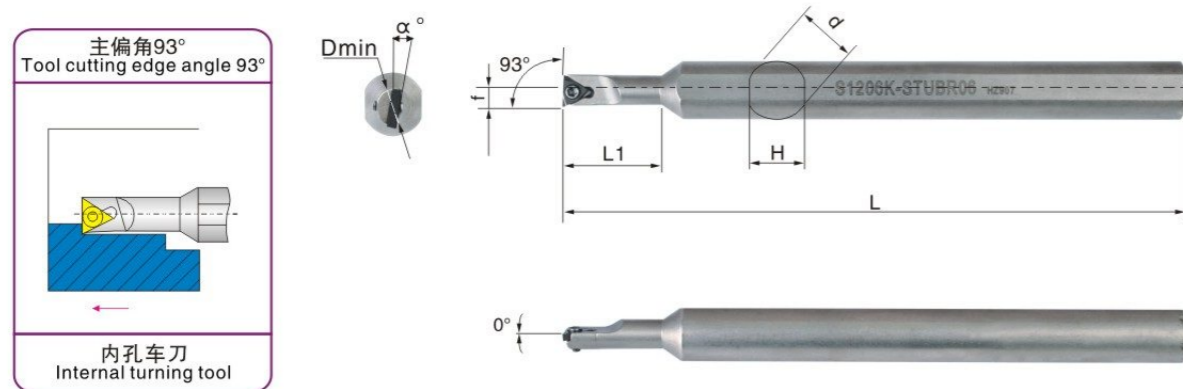

型号 Type	刀片 Blade	规格 Specification							螺丝 Screw	扳手 Wrench
		ϕ Dmin	ϕ d	L	L1	H	f	α°		
S07K-STUPR/L08-A12	TP□□0802□□	9	12	125	25	11	4.5	12°	M2.2 x 6	T6
S08M-STUPR/L08-A16		10	16	150	28	15	5	13°		
S08K-STUCR/L09-A12	TC□□0902□□	10	12	125	28	11	5.5	15°	M2.5 x 6	T8
S08M-STUCR/L09-A16		10	16	150	28	15	5.5	10°		
S10M-STUCR/L11-A16	TC□□1102□□	12	16	150	30	15	6	12°	M2.5 x 6	T8
S12M-STUCR/L11-A16		14	16	150	33	15	7	10°		
S10M-STUPR/L11-A16	TP□□1103□□	12	16	150	30	15	6	12°	M3 x 8	T8
S12M-STUPR/L11-A16		14	16	150	33	15	7	10°		

▲更多型号可咨询，可接受高要求非标定制

STUCR/L

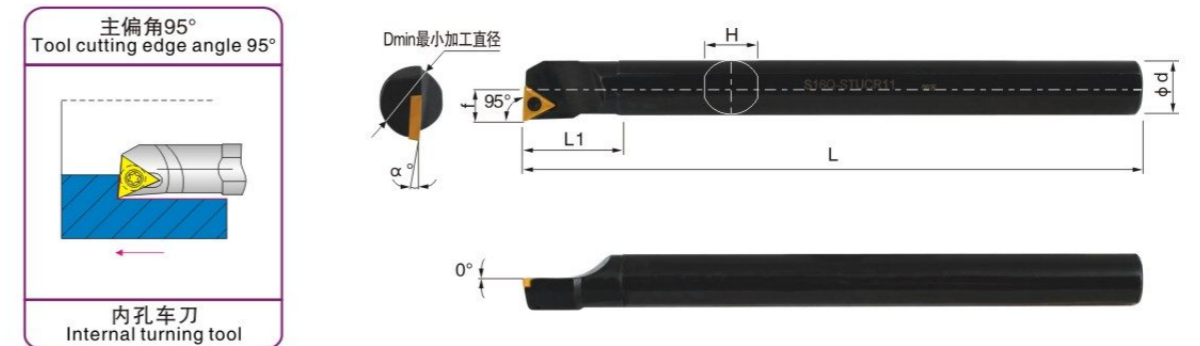

型号 Type	刀片 Blade	规格 Specification							螺丝 Screw	扳手 Wrench
		ϕ Dmin	ϕ d	f	L	L1	H	α°		
S08K-STUCR/L09	TC□□0902□□	10	8	5	125	23	7	15°	M2.2 x 6	T6
S10K-STUCR/L09		12	10	6	125	24	9	13°		
S08K-STUCR/L09B	TC□□0902□□	10	8	5	125	23	7	15°	M2.5 x 6	T8
S10K-STUCR/L09B		12	10	6	125	24	9	13°		
S10K-STUCR/L11	TC□□1102□□	12	10	6	125	24	9	12°	M2.5 x 6	T8
S12M-STUCR/L11		14	12	7	150	27	11	10°		
S14N-STUCR/L11		16	14	8	160	20	13	10°		
S16Q-STUCR/L11		18	16	9	180	30	15	8°		
S20R-STUCR/L11		22	20	11	200	35	19	6°		
S25S-STUCR/L11		28	25	13.5	250	40	24	4°		
S16Q-STUCR/L16		TC□□16T3□□	18	16	9.5	180	28	15		
S20R-STUCR/L16	23		20	11.5	200	40	19	8°		
S25S-STUCR/L16	28		25	14	250	40	24	6°	M4 x 10	T15
S32T-STUCR/L16	35		32	17.5	300	45	30	4°		

▲更多型号可咨询，可接受高要求非标定制

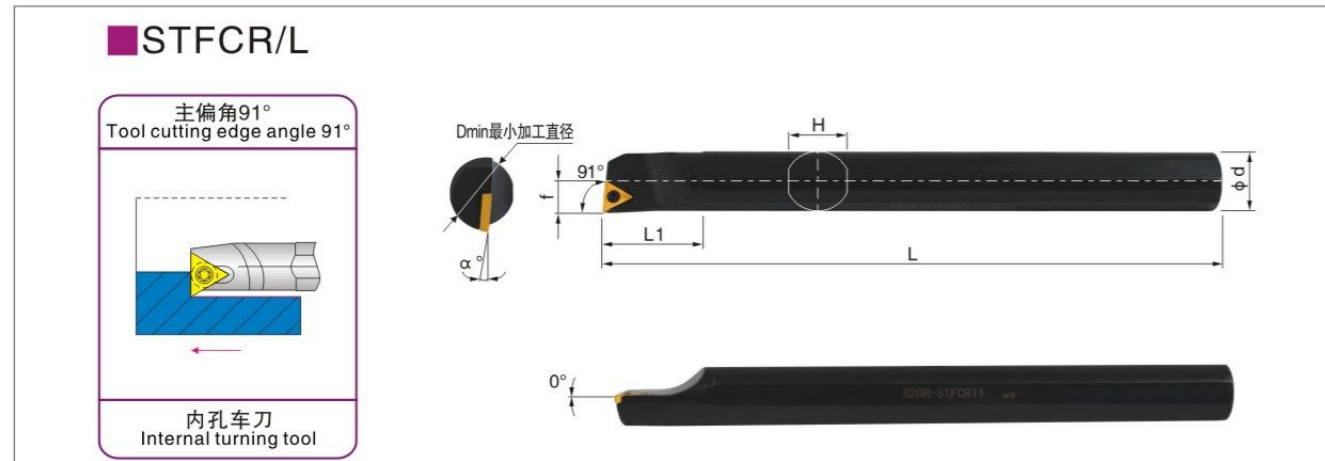

型号 Type	刀片 Blade	规格 Specification							螺丝 Screw	扳手 Wrench
		ϕ Dmin	ϕ d	f	L	L1	H	α°		
S08K-STFCR/L09	TC□□0902□□	10	8	5	125	23	7	15°	M2.2×6	T6
S10K-STFCR/L09		11	10	6	125	24	9	13°		
S12M-STFCR/L09		13	12	7	150	27	11	12°		
S08K-STFCR/L09B	TC□□0902□□	10	8	5	125	23	7	15°	M2.5×6	T8
S10K-STFCR/L09B		11	10	6	125	24	9	13°		
S12M-STFCR/L09B		13	12	7	150	27	11	12°		
S10K-STFCR/L11	TC□□1102□□	12	10	6	125	24	9	10°	M2.5×6	T8
S12M-STFCR/L11		14	12	7	150	27	11	8°		
S14N-STFCR/L11		16	14	8	160	27	13	8°		
S16Q-STFCR/L11		18	16	9	180	30	14	6°		
S20R-STFCR/L11	TC□□16T3□□	22	20	11.0	200	35	19	4°	M4×8	T15
S16Q-STFCR/L16		18	16	9.5	180	28	15	10°		
S20R-STFCR/L16		23	20	11.5	200	40	19	8°		
S25S-STFCR/L16		28	25	14	250	40	24	6°		
S32T-STFCR/L16	TC□□16T3□□	35	32	17.5	300	45	30	4°	M4×10	T15

▲更多型号可咨询, 可接受高要求非标定制

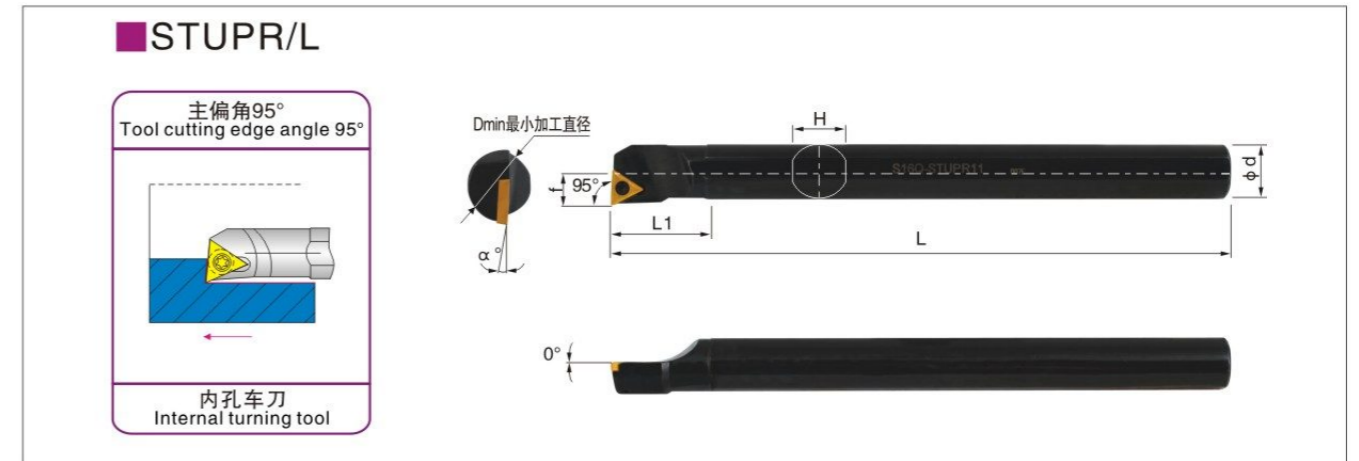

型号 Type	刀片 Blade	规格 Specification							螺丝 Screw	扳手 Wrench
		ϕ Dmin	ϕ d	f	L	L1	H	α°		
S08K-STUPR/L08	TP□□0802□□	10	8	5	125	20	7	15°	M2.2×6	T6
S10K-STUPR/L08		11	10	6	125	20	9	13°		
S1207K-STUPR/L08		9	12	4.4	125	25	11	15°		
S1608M-STUPR/L08	TP□□0902□□	10	16	5	150	28	15	15°	M2.5×6	T8
S08K-STUPR/L09		10	8	5	125	23	7	15°		
S10K-STUPR/L09		12	10	6	125	23	9	13°		
S12M-STUPR/L09	TP□□1103□□	14	12	7	150	23	11	10°	M3×8	T8
S10K-STUPR/L11		12	10	6	125	24	9	12°		
S12M-STUPR/L11		14	12	7	150	27	11	10°		
S14N-STUPR/L11		16	14	8	160	20	13	10°		
S16Q-STUPR/L11		18	16	9	180	30	15	8°		
S18Q-STUPR/L11		20	18	10	180	30	17	8°		
S20R-STUPR/L11		22	20	11	200	35	19	6°		

▲更多型号可咨询, 可接受高要求非标定制

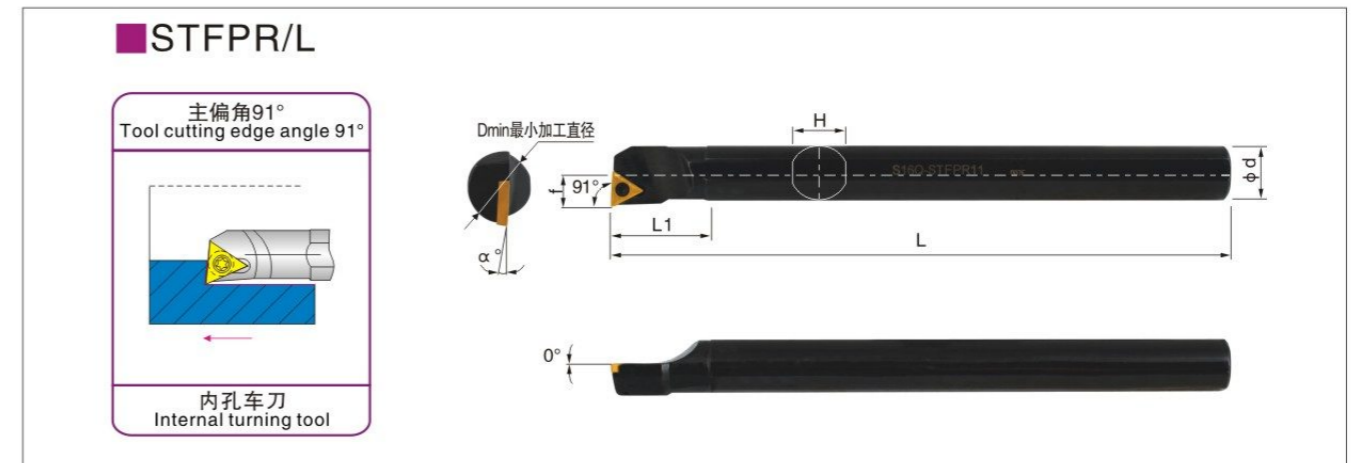

型号 Type	刀片 Blade	规格 Specification							螺丝 Screw	扳手 Wrench
		ϕ Dmin	ϕ d	f	L	L1	H	α°		
S08K-STFPR/L09	TP□□0902□□	10	8	5	125	23	7	15°	M2.5×6	T8
S10K-STFPR/L09		11	10	6	125	24	9	13°		
S12M-STFPR/L09		13.5	12	7	150	27	11	12°		
S10K-STFPR/L11	TP□□1103□□	12	10	6	125	24	9	10°	M3×8	T8
S12M-STFPR/L11		14	12	7	150	27	11	8°		
S14N-STFPR/L11		16	14	8	160	27	13	8°		
S16Q-STFPR/L11		18	16	9	180	30	14	6°		
S18Q-STFPR/L11		20	18	10	180	30	17	8°		
S20R-STFPR/L11		22	20	11	200	35	19	4°		

▲更多型号可咨询, 可接受高要求非标定制

STWCR/L

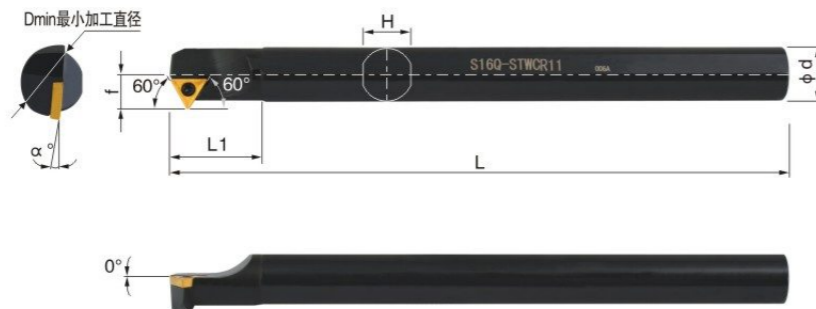
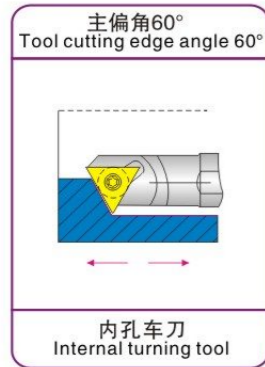

型号 Type	刀片 Blade	规格 Specification							螺丝 Screw	扳手 Wrench
		φ Dmin	φ d	f	L	L1	H	α°		
S08K-STWCR/L09B	TC□□0902□□	11	8	5.5	125	25	7	12°	M2.5×6	T8
S10K-STWCR/L11	TC□□1102□□	14	10	8	125	25	9	10°		
S12M-STWCR/L11		16	12	9	150	30	11	8°		
S14N-STWCR/L11		18	14	10	160	30	13	8°		
S16Q-STWCR/L11		20	16	11	180	30	15	6°		
S20R-STWCR/L11	TC□□16T3□□	25	20	13	200	35	19	4°	M4×10	T15
S20R-STWCR/L16		26	20	14.5	200	40	19	8°		
S25S-STWCR/L16		30	25	15	250	40	24	2°		

▲更多型号可咨询，可接受高要求非标定制

STWPR/L

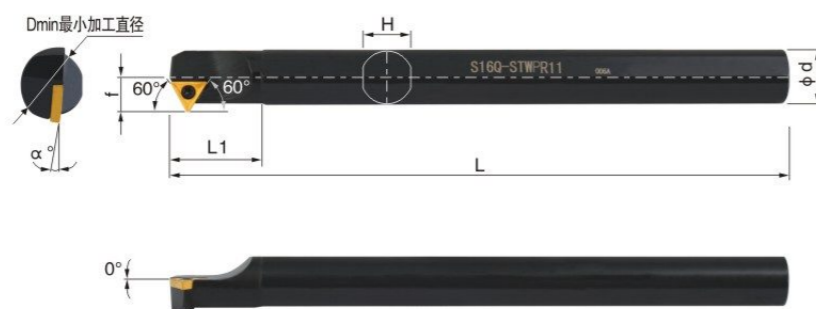
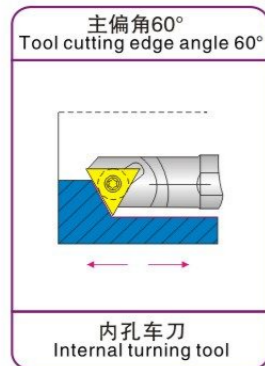

型号 Type	刀片 Blade	规格 Specification							螺丝 Screw	扳手 Wrench
		φ Dmin	φ d	f	L	L1	H	α°		
S08K-STWPR/L09	TC□□0902□□	11	8	5.5	125	25	7	12°	M2.5×6	T8
S10K-STWPR/L11	TP□□1103□□	14	10	8	125	25	9	10°		
S12M-STWPR/L11		16	12	9	150	30	11	8°		
S14N-STWPR/L11		18	14	10	160	30	13	8°		
S16Q-STWPR/L11		20	16	11	180	30	15	6°		
S20R-STWPR/L11		25	20	13	200	35	19	4°		

▲更多型号可咨询，可接受高要求非标定制

SSSCR/L

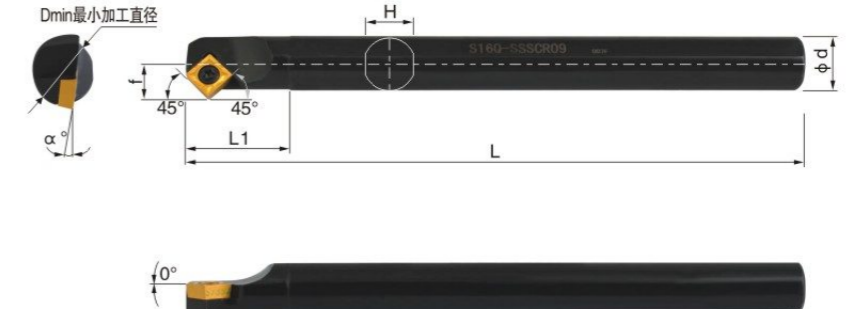
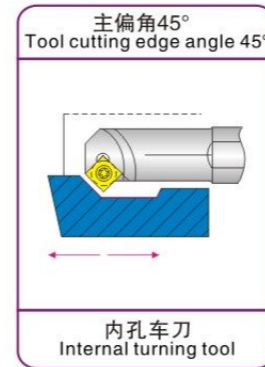

型号 Type	刀片 Blade	规格 Specification							螺丝 Screw	扳手 Wrench
		φ Dmin	φ d	f	L	L1	H	α°		
S12M-SSSCR/L09	SC□□09T3□□	16	12	8.5	150	30	11	12°	M4×8	T15
S14N-SSSCR/L09		19	14	10.5	160	30	13	12°		
S16Q-SSSCR/L09		21	16	11.5	180	35	15	10°		
S18Q-SSSCR/L09		23	18	12.5	180	35	17	10°	M4×10	
S20R-SSSCR/L09		25	20	13.5	200	40	19	8°		
S25S-SSSCR/L09		30	25	16	250	40	24	6°		
S32T-SSSCR/L09		37	32	19.5	300	45	30	4°		

▲更多型号可咨询，可接受高要求非标定制

SSKCR/L

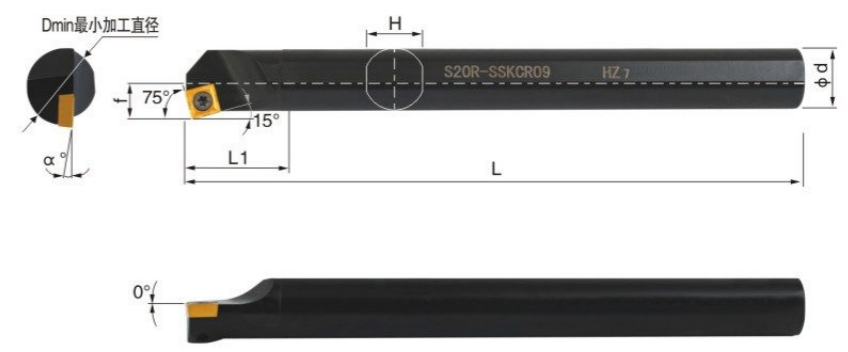
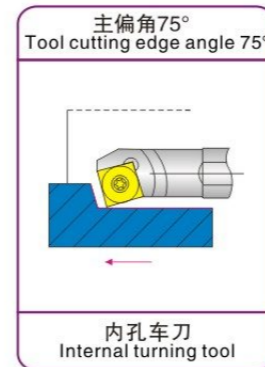

型号 Type	刀片 Blade	规格 Specification							螺丝 Screw	扳手 Wrench
		φ Dmin	φ d	f	L	L1	H	α°		
S12M-SSKCR/L09	SC□□09T3□□	16	12	8.5	150	30	11	12°	M4×8	T15
S14N-SSKCR/L09		19	14	9.5	160	30	13	12°		
S16Q-SSKCR/L09		20	16	10.5	180	30	15	10°		
S18Q-SSKCR/L09		22	18	11.5	180	40	17	10°	M4×10	
S20R-SSKCR/L09		24	20	12.5	200	40	19	8°		
S25S-SSKCR/L09		30	25	15	250	40	24	6°		

▲更多型号可咨询，可接受高要求非标定制

SVQ*R/L

主偏角117.5°
Tool cutting edge angle 117.5°

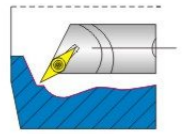

内孔车刀
Internal turning tool

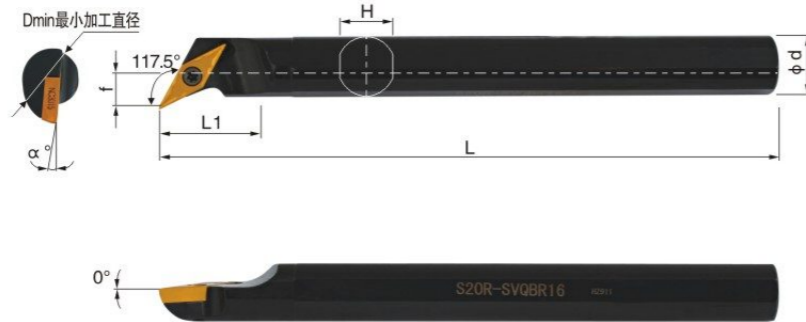

型号 Type C刀片后角7° B刀片后角5°	刀片 Blade	规格 Specification							螺丝 Screw	扳手 Wrench
		φ Dmin	φ d	f	L	L1	H	α° B C		
S16Q-SVQ-R/L11	VC□□1103□□	21	16	11.5	180	35	15	10° 8°	M2.5×7	T8
S20R-SVQ-R/L11	VB□□1103□□	26	20	14	200	39	19	8° 6°		
S20R-SVQ-R/L16		26	20	14	200	50	19	10° 8°		
S25S-SVQ-R/L16	VC□□1604□□	32	25	16.5	250	50	24	8° 6°	M4×10	T15
S32T-SVQ-R/L16	VB□□1604□□	41	32	22.5	300	55	30	10° 8°		
S40T-SVQ-R/L16		49	40	27	300	55	38	8° 6°		

▲更多型号可咨询, 可接受高要求非标定制

SVW*R/L

主偏角72.5°
Tool cutting edge angle 72.5°

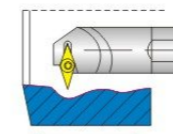

内孔车刀
Internal turning tool



型号 Type C刀片后角7° B刀片后角5°	刀片 Blade	规格 Specification							螺丝 Screw	扳手 Wrench
		φ Dmin	φ d	f	L1	L	H	α° B C		
S10K-SVWCR08	VC□□0802□□	15	10	10	125	125	9	12°	M2.0×5	T6
S12M-SVWCR08		16	12	8.7	150	150	11	12°		
S14M-SVWCR08		18	14	10.5	125	150	13	12°		
S16Q-SVW□R11	VB□□1103□□	23	16	15	20	180	14.8	12°	M2.5×7	T8
S20R-SVW□R11	VC□□1103□□	27	20	17	28	200	18.6	10°		
S20R-SVW□R16	VB□□1103□□	35	20	17	28	200	18.6	10°	M4×10	T10
S25S-SVW□R16	VC□□1103□□	38	25	23	33	250	23.4	10°		
S32T-SVW□R16		44	25	26	41	250	30	8°		

▲更多型号可咨询, 可接受高要求非标定制

SVU*R/L

主偏角95°
Tool cutting edge angle 95°

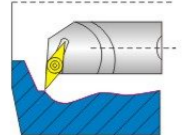

内孔车刀
Internal turning tool

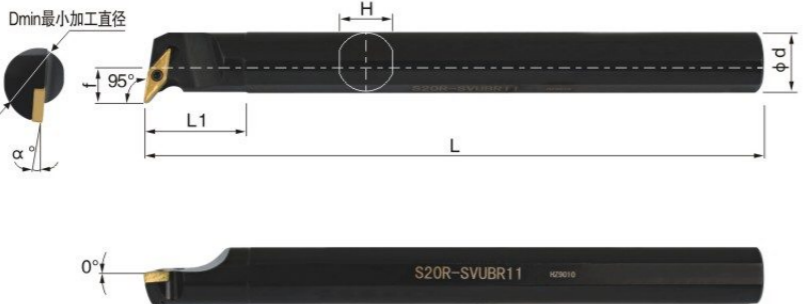

型号 Type C刀片后角7° B刀片后角5°	刀片 Blade	规格 Specification							螺丝 Screw	扳手 Wrench
		φ Dmin	φ d	f	L	L1	H	α° B C		
S10K-SVUCR08	VC□□0802□□	15	10	9.5	125	14	9	12° 10°	M2.0×5	T6
S12M-SVUCR08		16	12	9.5	150	15	11	12° 10°		
S14N-SVUCR08		18	14	10.5	160	18	13	10° 8°		
S16Q-SVU-R/L11	VC□□1103□□	22	16	12.5	180	30	15	10° 8°	M2.5×7	T8
S20R-SVU-R/L11	VB□□1103□□	26	20	14	200	32	19	8° 6°		
S20R-SVU-R/L16		31	20	20	200	50	19	10° 8°	M4×10	T15
S25S-SVU-R/L16	VC□□1604□□	35	25	20	250	50	24	8° 6°		
S32T-SVU-R/L16	VB□□1604□□	41	32	22.5	300	50	30	10° 8°		
S40T-SVU-R/L16		49	40	27	300	55	38	8° 6°		

▲更多型号可咨询, 可接受高要求非标定制

SVX*R/L

主偏角96°
Tool cutting edge angle 96°

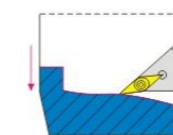

内孔车刀
Internal turning tool

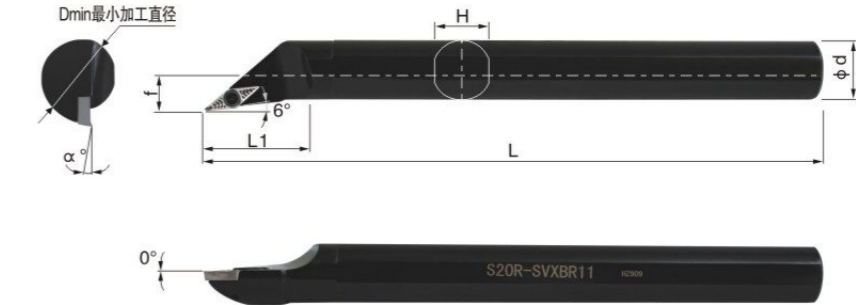

型号 Type C刀片后角7° B刀片后角5°	刀片 Blade	规格 Specification							螺丝 Screw	扳手 Wrench
		φ Dmin	φ d	f	L	L1	H	α° B C		
S16Q-SVX-R/L11	VC□□1103□□	22	16	11.5	180	40	15	10° 8°	M2.5×7	T8
S20R-SVX-R/L11	VB□□1103□□	26	20	13.5	200	45	19	8° 6°		
S20R-SVX-R/L16		26	20	13.5	200	50	19	10° 8°	M4×10	T15
S25S-SVX-R/L16	VC□□1604□□	31	25	16	250	50	24	8° 6°		
S32T-SVX-R/L16	VB□□1604□□	38	32	19.5	300	60	30	10° 8°		
S40T-SVX-R/L16		46	40	23.5	300	65	38	8° 6°		

▲更多型号可咨询, 可接受高要求非标定制

SVJ*R/L

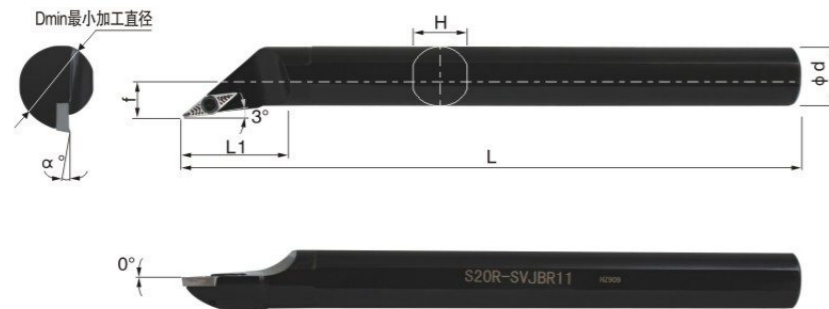
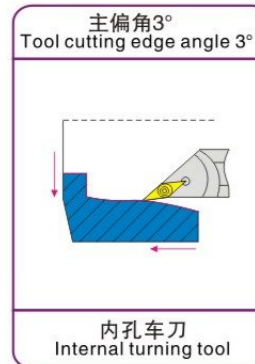

型号 Type	刀片 Blade	规格 Specification							螺丝 Screw	扳手 Wrench
		phi Dmin	phi d	f	L	L1	H	alpha°		
S16Q-SVJ-R/L11	VC□□1103□□	22	16	11.5	180	40	15	10° 8°	M2.5 x 7	T8
S20R-SVJ-R/L11	VB□□1103□□	26	20	13.5	200	45	19	8° 6°		
S20R-SVJ-R/L16		26	20	13.5	200	50	19	10° 8°		
S25S-SVJ-R/L16	VC□□1604□□	31	25	16	250	50	24	8° 6°	M4 x 10	T15
S32T-SVJ-R/L16	VB□□1604□□	38	32	19.5	300	60	30	10° 8°		
S40T-SVJ-R/L16		46	40	23.5	300	65	38	8° 6°		

▲更多型号可咨询, 可接受高要求非标定制

SWLCR/L

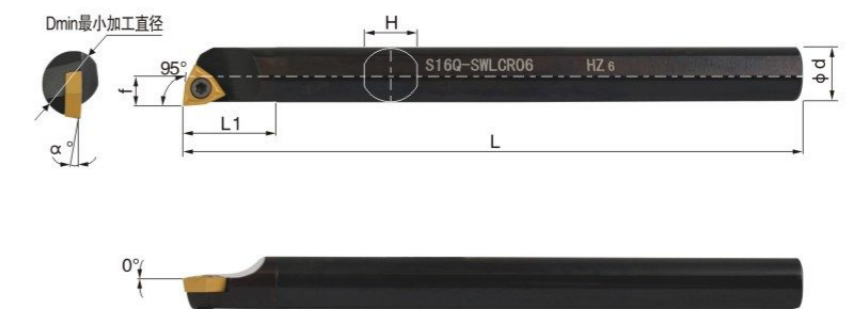
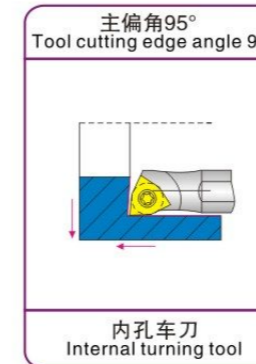

型号 Type	刀片 Blade	规格 Specification							螺丝 Screw	扳手 Wrench
		phi Dmin	phi d	f	L	L1	H	alpha°		
S08K-SWLCR/L04	WC□□0402□□	10	8	5	125	25	7	13°	M3 x 6	T10
S10K-SWLCR/L04		13	10	6.5	125	30	9	10°		
S12M-SWLCR/L04		16	12	7.5	150	37	11	13°		
S16Q-SWLCR/L06	WC□□06T3□□	20	16	9.5	180	40	15	10°	M4 x 10	T15
S20R-SWLCR/L06		24	20	11.5	200	40	19	8°		
S25S-SWLCR/L06		29	25	14	250	40	24	6°		

▲更多型号可咨询, 可接受高要求非标定制

SVZ*R/L

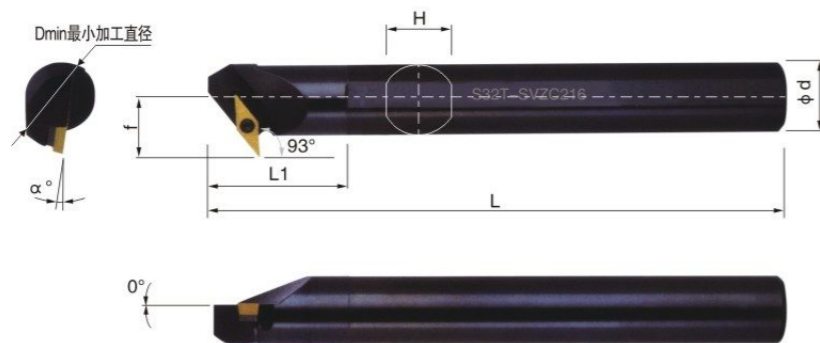
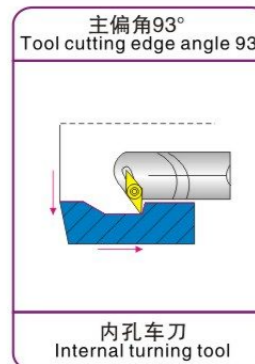

型号 Type	刀片 Blade	规格 Specification							螺丝 Screw	扳手 Wrench
		phi Dmin	phi d	f	L	L1	H	alpha°		
S16Q-SVZ-R/L11	VC□□1103□□	22	16	11.5	180	34	15	10° 8°	M2.5 x 7	T8
S20R-SVZ-R/L11	VB□□1103□□	27	20	14	200	38	19	8° 6°		
S25S-SVZ-R/L16		34	25	19.5	250	50	20	8° 6°		
S32T-SVZ-R/L16	VC□□1604□□	42	32	23.5	300	50	30	10° 8°	M4 x 10	T15
S40T-SVZ-R/L16	VB□□1604□□	50	40	27	300	60	38	8° 6°		

▲更多型号可咨询, 可接受高要求非标定制

SWUBR/L

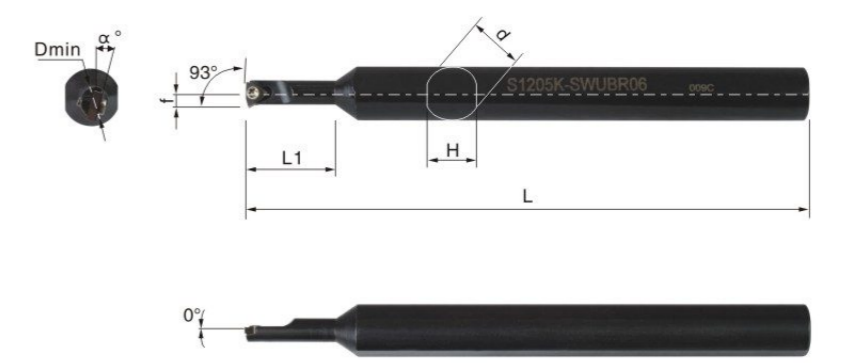
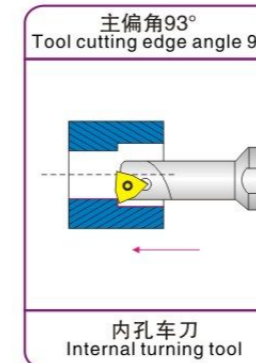

型号 Type	刀片 Blade	规格 Specification							螺丝 Screw	扳手 Wrench
		phi Dmin	phi d	f	L	L1	H	alpha°		
S06H-SWUBR/L06	WBG060102	7	6	3.5	100	16	5.4	15°	M2.2 x 5	T6
S0705H-SWUBR/L06		6	7	3	100	16	6	15°		
S0805H-SWUBR/L06		6	8	3	100	16	7	15°		
S1005K-SWUBR/L06		6	10	3	125	16	9	15°		
S1205K-SWUBR/L06		6	12	3	125	20	11	15°		
S1605K-SWUBR/L06		6	16	3	125	20	15	15°		
S0806J-SWUBR/L06		7	8	3.5	110	20	7	15°		
S1006K-SWUBR/L06		7	10	3.5	125	20	9	12°		
S1207K-SWUBR/L06		8	12	4	125	25	11	12°		
S1607M-SWUBR/L06		8	16	4	150	25	15	12°		

▲更多型号可咨询, 可接受高要求非标定制

SWDCR/L

主偏角95°
Tool cutting edge angle 95°

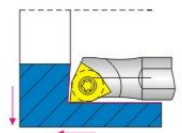

内孔车刀
Internal turning tool

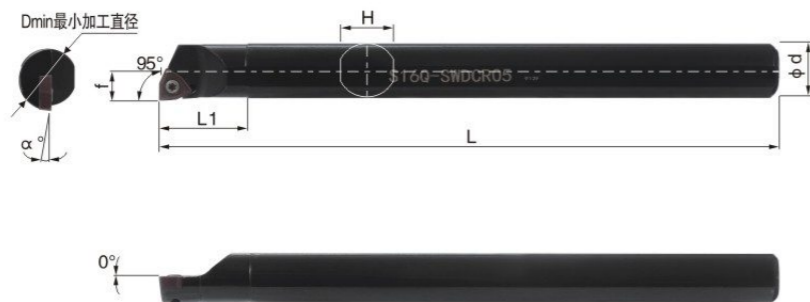

型号 Type	刀片 Blade	规格 Specification							螺丝 Screw	扳手 Wrench
		ϕ Dmin	ϕ d	f	L	L1	H	α°		
S08K-SWDCR04	WCMT040208	9	8	5	125	25	7	0°	M3X7	T8
S10K-SWDCR04		11	10	6	125	25	9	0°		
S12M-SWDCR04		13	12	7	150	30	11	0°		
S14N-SWDCR05	WCMT050308	16	14	8	160	30	13	0°	M3X8	T8
S16Q-SWDCR05		18	16	9	180	35	14.8	0°		
S20R-SWDCR06	WCMT060408	22	20	11	200	35	18.6	0°	M3.5X10	T15
S25S-SWDCR06		27	25	13.5	250	40	23.4	0°		

▲更多型号可咨询, 可接受高要求非标定制

专利产品 专利号: 2L2013 2 0320285.8

SCLNR/L 95°

主偏角95°
Tool cutting edge angle 95°

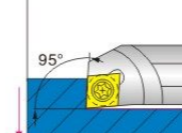

内孔车刀
Internal turning tool

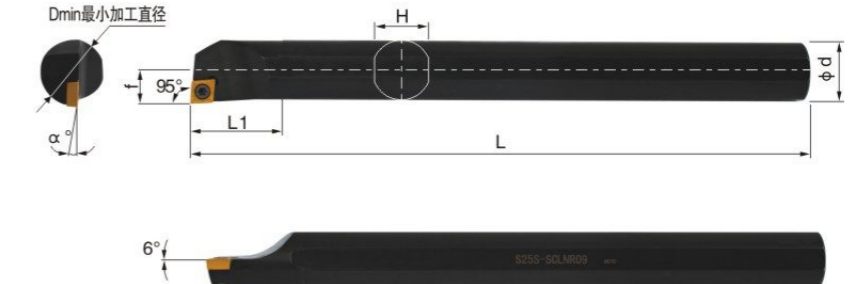

型号 Type	刀片 Blade	规格 Specification							螺丝 Screw	扳手 Wrench
		ϕ Dmin	ϕ d	L	L1	H	f	α°		
S16Q-SCLNR/L12	CN□□1204□□	19	16	180	26	15	9.5	15°	M4.5 × 14W	T20
S18Q-SCLNR/L12		21	18	180	28	16.8	10.5	15°		
S20R-SCLNR/L12		23	20	200	28	18.4	11.5	15°		

▲更多型号可咨询, 可接受高要求非标定制

STUNR/L 93°

专利产品 专利号: 2L2013 2 0320285.8

主偏角93°
Tool cutting edge angle 93°

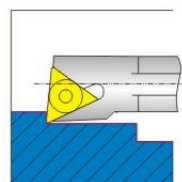

内孔车刀
Internal turning tool

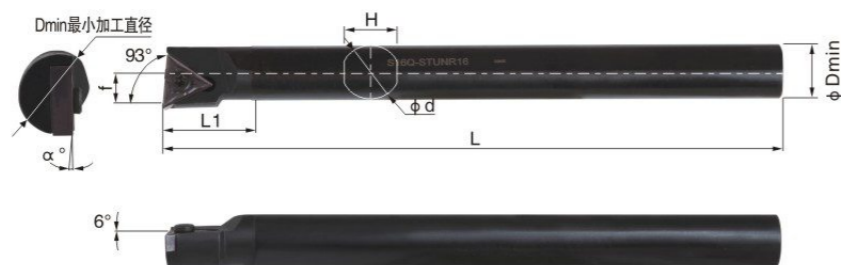

型号 Type	刀片 Blade	规格 Specification							螺丝 Screw	扳手 Wrench
		ϕ Dmin	ϕ d	L	L1	H	f	α°		
S16Q-STUNR/L16	TN□□1604□□	19	16	180	26	14.8	9	15°	M3.5 × 13T	T15
S18Q-STUNR/L16		20	18	180	28	16.8	10	15°		
S20R-STUNR/L16		22	20	200	28	18.4	11	15°		

▲更多型号可咨询, 可接受高要求非标定制

SCKNR/L 75°

专利产品 专利号: 2L2013 2 0320285.8

主偏角75°
Tool cutting edge angle 75°

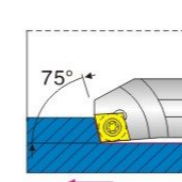

内孔车刀
Internal turning tool

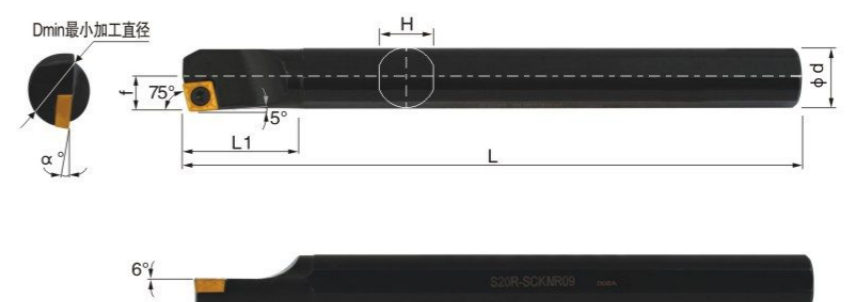

型号 Type	刀片 Blade	规格 Specification							螺丝 Screw	扳手 Wrench
		ϕ Dmin	ϕ d	L	L1	H	f	α°		
S16Q-SCKNR/L12	CN□□1204□□	19	16	180	26	15	9.5	15°	M4.5 × 14W	T20
S18Q-SCKNR/L12		20	18	180	28	16.8	10.5	15°		
S20R-SCKNR/L12		23	20	200	28	18.4	11.5	15°		

▲更多型号可咨询, 可接受高要求非标定制

STFNR/L 91°

专利产品 专利号: 2L2013 2 0320285.8

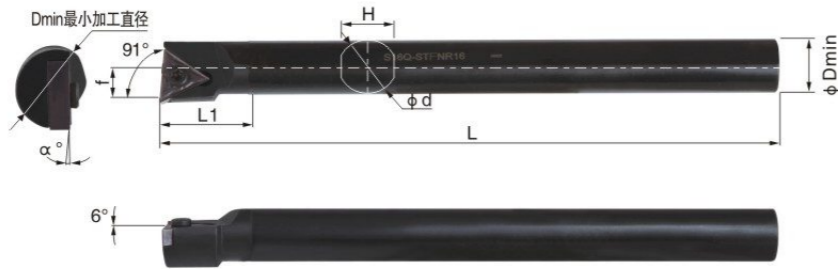
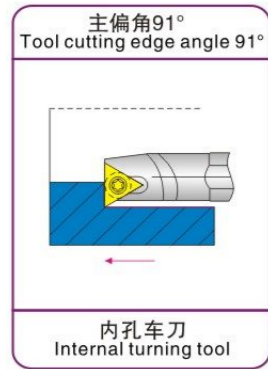

型号 Type	刀片 Blade	规格 Specification							螺丝 Screw	扳手 Wrench
C刀片后角7° B刀片后角5°		ϕD_{min}	ϕd	L	L1	H	f	α°		
S16Q-STFNR/L16	TN□□1604□□	18	16	180	26	15	9	15°	M3.5×13T	T15
S18Q-STFNR/L16		21	18	180	28	16.8	10	15°		
S20R-STFNR/L16		22	20	200	28	18.4	11	15°		

▲更多型号可咨询, 可接受高要求非标定制

STLNR/L 95°

专利产品 专利号: 2L2013 2 0320285.8

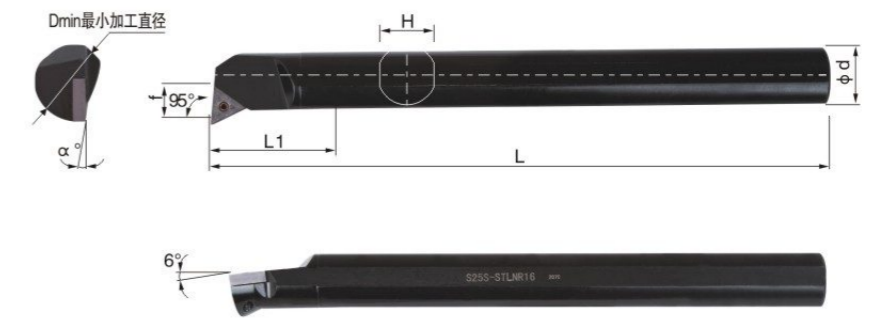
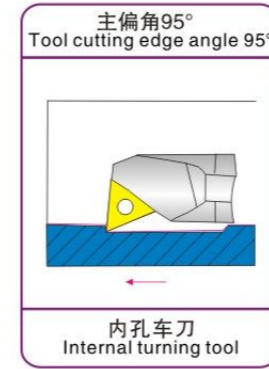

型号 Type	刀片 Blade	规格 Specification							螺丝 Screw	扳手 Wrench
C刀片后角7° B刀片后角5°		ϕD_{min}	ϕd	L	L1	H	f	α°		
S16Q-STLNR/L16	TN□□1604□□	21	16	180	26	15	11.5	15°	M3.5×13T	T15
S18Q-STLNR/L16		23	18	180	28	16.8	12.5	15°		
S20R-STLNR/L16		25	20	200	28	18.4	13.5	15°		

▲更多型号可咨询, 可接受高要求非标定制

STQNR/L 105°

专利产品 专利号: 2L2013 2 0320285.8

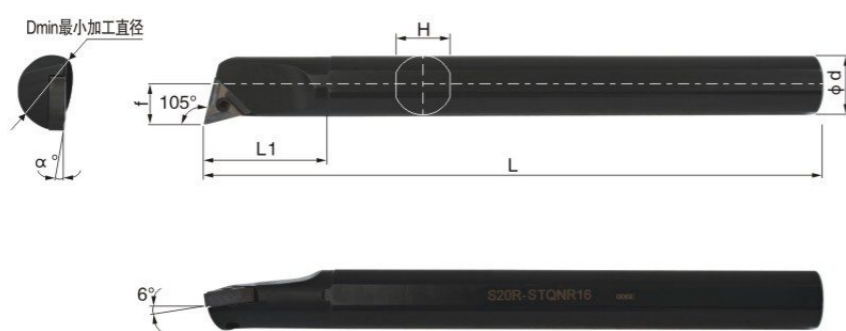
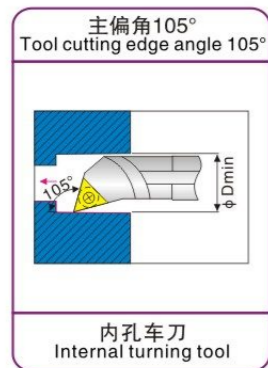

型号 Type	刀片 Blade	规格 Specification							螺丝 Screw	扳手 Wrench
C刀片后角7° B刀片后角5°		ϕD_{min}	ϕd	L	L1	H	f	α°		
S16Q-STQNR/L16	TN□□1604□□	21	16	180	26	15	11.5	15°	M3.5×13T	T15
S18Q-STQNR/L16		23	18	180	28	16.8	12.5	15°		
S20R-STQNR/L16		25	20	200	28	18.4	13.5	15°		

▲更多型号可咨询, 可接受高要求非标定制

STWNR/L 60°

专利产品 专利号: 2L2013 2 0320285.8

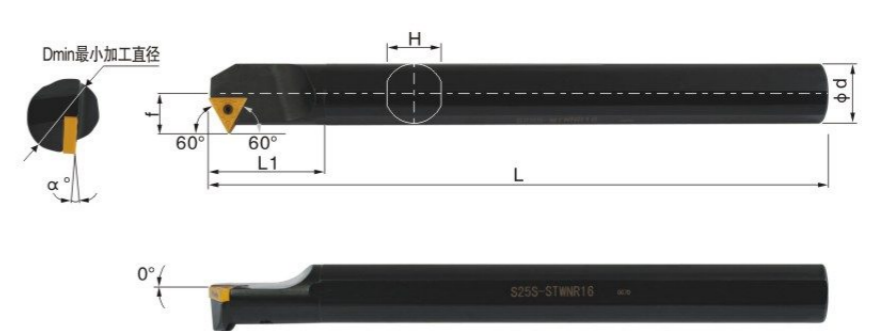
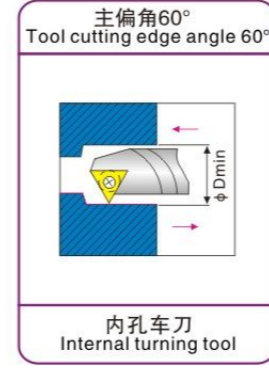

型号 Type	刀片 Blade	规格 Specification							螺丝 Screw	扳手 Wrench
C刀片后角7° B刀片后角5°		ϕD_{min}	ϕd	L	L1	H	f	α°		
S16Q-STWNR/L16	TN□□1604□□	21	16	180	26	15	11.5	15°	M3.5×13T	T15
S18Q-STWNR/L16		23	18	180	28	16.8	12.5	15°		
S20R-STWNR/L16		25	20	200	28	18.4	13.5	15°		

▲更多型号可咨询, 可接受高要求非标定制

SWLNR/L 95°

专利产品 专利号: 2L2013 2 0320285.8

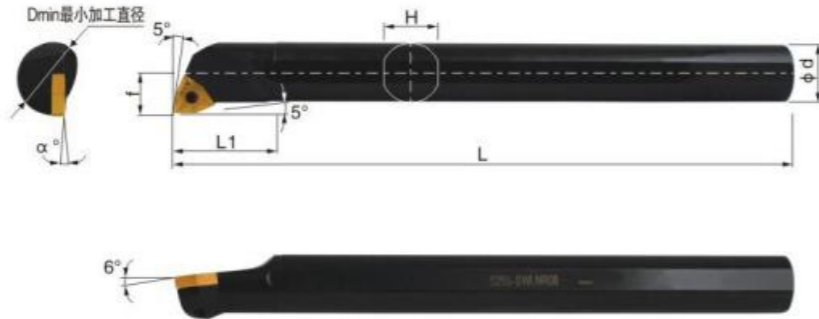
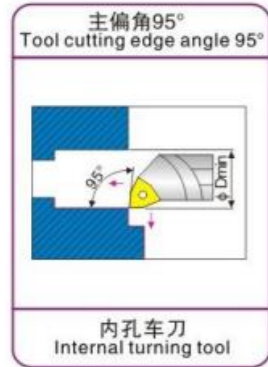

型号 Type	刀片 Blade	规格 Specification							螺丝 Screw	扳手 Wrench
		ϕ Dmin	ϕ d	L	L1	H	f	α°		
S16Q-SWLNR/L08	WN□□0804□□	21	16	180	26	15	11.5	15°	M4.5 x 14W	T20
S18Q-SWLNR/L08		23	18	180	28	16.8	12.5	15°		
S20R-SWLNR/L08		25	20	200	28	18.4	13.5	15°		

▲更多型号可咨询, 可接受高要求非标定制

专利产品

专利号: 2L2013 2 0297867.9

阻尼深孔车刀

Deep turning damping

H+Z镗刀杆的特点

根据电子计算机仿真解析而设计的高刚性+轻的刀头形状。可防止挠曲，使振动衰减。抗振效果为以往刀杆的两倍。

专利产品 专利号：2L2013 2 0297867.9

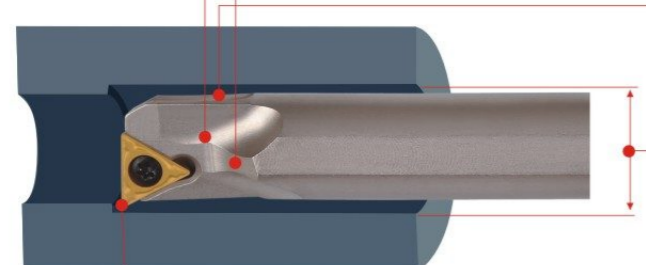

- 2个方向有容屑槽，排屑性能良好。
- 设计制造了凹窝，减轻了刀头重量并防止了振动。
- 可加工的最小直径超越了ISO标准。
- 注重表面质量时用F、FS型断屑槽。注重排屑性能时用MV型断屑槽。注重耐磨性能时用超高压烧结刀片。

防止挠曲的效果

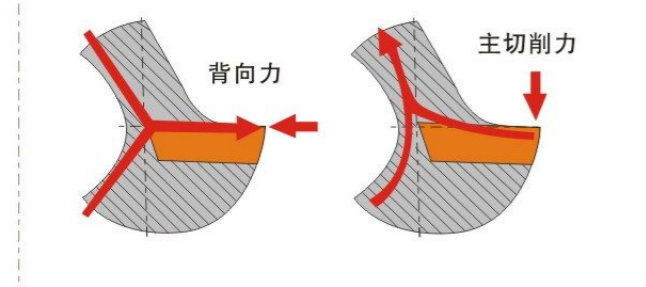

凹窝形成了独特的断面形状，使切削力中主切削力和背向力得到良好的平衡，挠曲量减少了17%。

镗刀杆	挠曲量
H+Z镗刀杆	28.3 μm
以往产品	34 μm

振动衰减的效果

刀头重量	振动停止时间
49.7g	15.8ms

5倍径

刀头重量轻，减少了切削时的振动。

刀头重量	振动停止时间
70.1g	20ms

3倍径

上述仿真是刀柄FSCLP1816R-09S在l/d=5、切削深度为0.5mm和进给量为0.05mm/rev的加工条件下作出的。

关于CCG/MT·CPG/MT·CPMX·TPG/MX刀片的使用

对于H+Z镗刀杆，只要更换夹紧螺钉，就可换用如下表所示的刀片。

对应刀柄：FSCLC/P·FSCLC/P...E

刀片型号	夹紧螺钉
CCG/MT0602○○(Φ6.35)	使用原螺钉不变
CPG/MT0802○○(Φ7.94)	请改用TS3型
CPG/MT0903○○(Φ9.525)	请改用TS4型
CPMX0802○○(Φ7.94)	使用原螺钉不变

对应刀柄：FSTUP·FSTUP...E

刀片型号	夹紧螺钉
CPMX0903○○(Φ9.525)	使用原螺钉不变
TPG/MX0802○○(Φ4.76)	请改用CS200T型
TPG/MX0902○○(Φ5.56)	请改用CS250T型
TPG/MX1103○○(Φ9.525)	请改用CS300890T型

如变更螺钉过长，可用砂轮等削短。
注：TPMT/W09,11型的夹紧螺钉尺寸不同，因而无法安装。

SCLCR/L

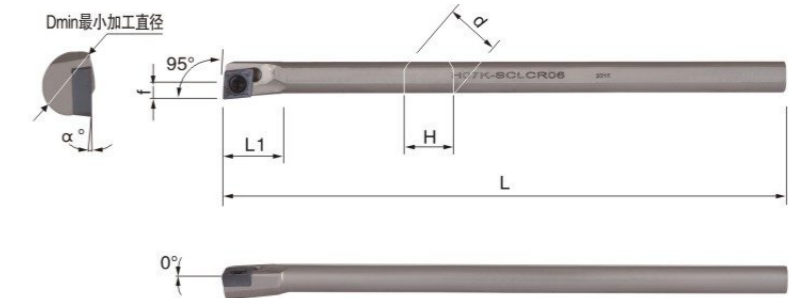
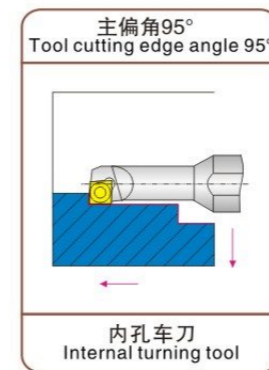

型号 Type	刀片 Blade	规格 Specification							螺丝 Screw	扳手 Wrench
		φ Dmin	φ d	f	L	L1	H	α°		
H04F-SCLCR/03	CC□□03T0□□	4.8	4	2.5	80	15	3.6	15°	M1.8×4	T6
H05G-SCLCR/03		5.5	5	2.8	90	15	4.5	15°		
H05H-SCLCR/04		5.8	5	2.8	100	22	4.5	15°		
H07K-SCLCR/06	CC□□0602□□	9	7	4.9	125	35	6	15°	M2.5×6	T8
H08K-SCLCR/06		10	8	5	125	40	7	15°		
H10K-SCLCR/06		12	10	6	125	50	9	13°		
H12M-SCLCR/06		14	12	7	150	60	11	10°		
H12M-SCLCR/09	CC□□09T3□□	16	12	9	150	60	11	12°	M4×8	T15
H14Q-SCLCR/09		16	14	8.5	180	70	13	12°		
H16R-SCLCR/09		18	16	9.5	200	80	15	12°		
H18R-SCLCR/09		20	18	10.5	200	90	17	8°		
H20X-SCLCR/09		22	20	11.5	230	100	19	8°		

▲更多型号可咨询，可接受高要求非标定制

SDUCR/L

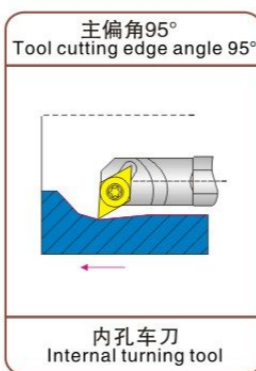

型号 Type	刀片 Blade	规格 Specification							螺丝 Screw	扳手 Wrench
		φ Dmin	φ d	f	L	L1	H	α°		
H10K-SDUCR/L07	DC□□0702□□	15	10	8	125	50	9	10°	M2.5×6	T8
H12M-SDUCR/L07		17	12	9	150	60	11	8°		

▲更多型号可咨询，可接受高要求非标定制

STUBR/L

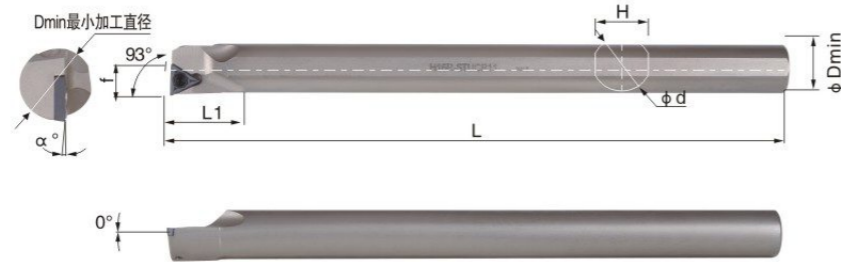
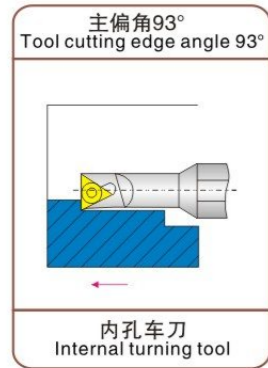

型号 Type	刀片 Blade	规格 Specification							螺丝 Screw	扳手 Wrench
		φ Dmin	φ d	f	L	L1	H	α°		
H06J-STUBR/L06	TB□□0601□□	7	6	4	110	25	5.4	12°	M2.2 × 5	T6
H0806J-STUBR/L06		7	8	3.6	110	25	7	12°		
H1006K-STUBR/L06		7	10	4	125	25	9	12°		
H1206K-STUBR/L06		7	12	4	125	25	11	12°		
H08K-STU□R/L09	TC□□0902□□ TP□□0902□□	10	8	5.5	125	40	7	15°	M2.5 × 6	T8
H10K-STU□R/L11	TC□□1102□□ TP□□1103□□	12	10	6	125	50	9	12°	M2.5 × 6 M3 × 8	T8
H12M-STU□R/L11		14	12	7	150	60	11	10°		
H16R-STU□R/L11		18	16	9	200	80	15	8°		
H16R-STUCR/L16	TC□□16T3□□	19	16	9.5	200	80	15	8°	M4 × 10	T15
H18R-STUCR/L16		20	18	10.5	200	80	17	8°		
H20X-STUCR/L16		22	20	11.5	230	80	19	6°		

▲更多型号可咨询，可接受高要求非标定制

SWUBR/L

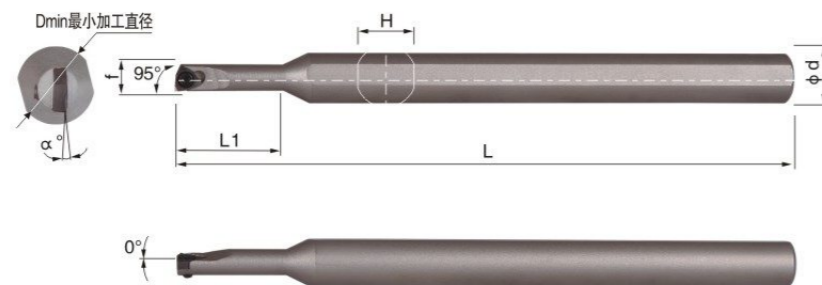
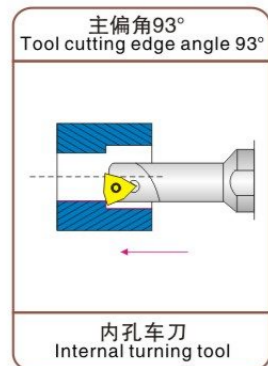

型号 Type	刀片 Blade	规格 Specification							螺丝 Screw	扳手 Wrench
		φ Dmin	φ d	f	L	L1	H	α°		
H06J-SWUBR/L06	WB□□0601□□	7	6	3.4	110	12	5.4	15°	M2.2 × 5	T6
H1005K-SWUBR/L06		6	10	3	125	22	9	15°		
H1205K-SWUBR/L06		6	12	3	125	22	11	15°		

▲更多型号可咨询，可接受高要求非标定制

HNR

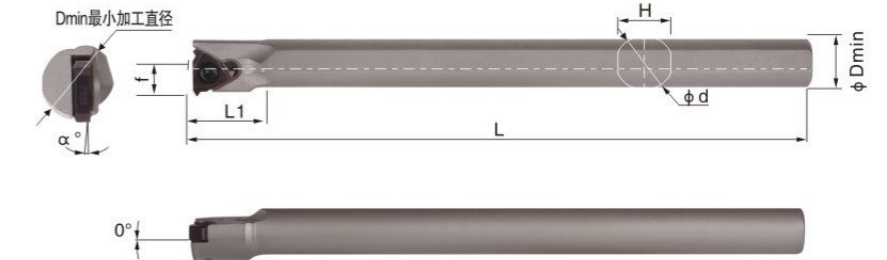
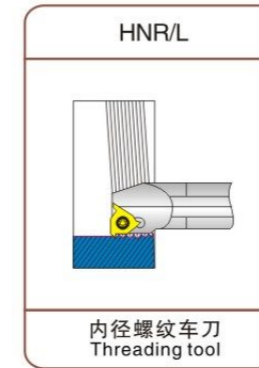

型号 Type	刀片 Blade	规格 Specification							螺丝 Screw	扳手 Wrench
		φ Dmin	φ d	f	L	L1	H	α°		
HNR0006K06J06	06□R□□	8	6	4	110	12	5.4	15°	M2 × 5	T6
HNR0006K06-A10	06□R□□	8	10	4	125	25	9	15°		
HNR0007J08	06□R□□	10	7	5.3	110	12	6.2	15°		
HNR0008K08	08□R□□	10	8	5.5	125	12	7	15°	M2.5 × 6	T6
HNR0010K11	11□R□□	12	10	6.8	125	15	9	15°	M2.5 × 6	T6
HNR0012M11	11□R□□	16	12	6.6	150	15	11	15°		
HNR0013N16	16□R□□	18	13	9	160	22	12	15°	M3.5 × 10	T15
HNR0016R16	16□R□□	20	16	10.5	200	25	15	15°		

▲更多型号可咨询，可接受高要求非标定制

HNGR/L

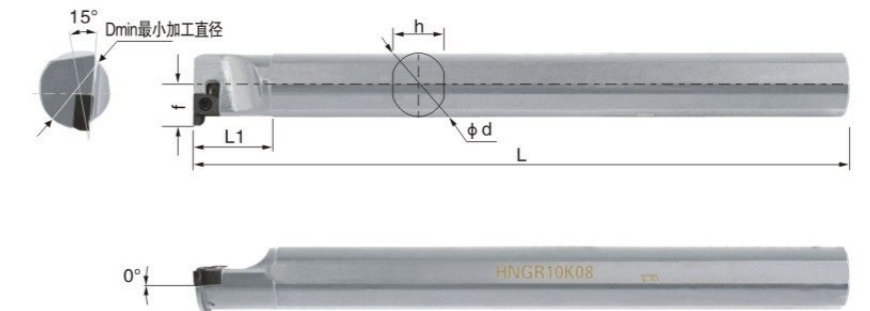
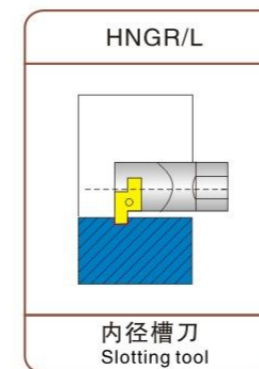

型号 Type	刀片 Blade	规格 Specification						螺丝 Screw	扳手 Wrench
		Tmax	φ d	F	L1	L	H		
HNGR08J06	6GR/L	2	8	4.7	15	110	7	M2.2 × 4	T7
HNGR08J07	7GR/L	2	8	5.8	15	110	7	M2.5 × 6	T7
HNGR10K08	8GR/L	3.5	10	7.6	20	125	8	M2.5 × 6	T7

▲更多型号可咨询，可接受高要求非标定制



螺纹车刀系列

Threading tool

www.wercerl.com

螺纹车刀型号编制说明

Preparation description for screw turning tool



螺纹刀片型号编制说明

Preparation description for model of screw blade



SNR/L

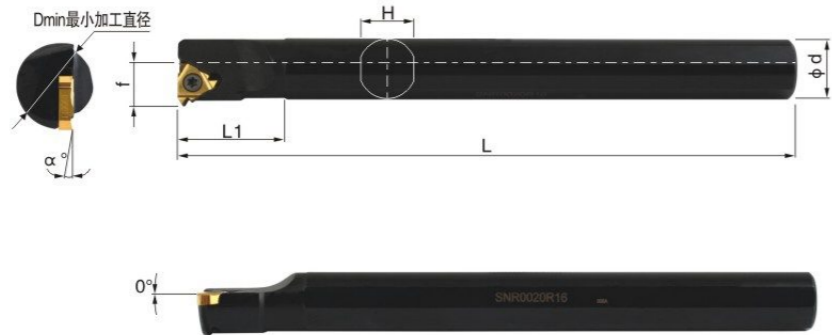
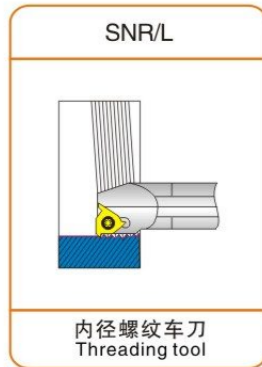

型号 Type	刀片 Blade	规格 Specification							垫片 Shim	螺丝 Screw	扳手 Wrench	侧螺丝 Lateral screw
		φDmin	φ d	f	L	L1	H	α°				
SNR/L0007J08	08NR/L□□	9	7	5.3	110	15	6.4	15°	/	M2.2×6	T6	M3×8C
SNR/L0008K08		11	8	6.6	125	15	7					
SNR/L0008K11		11	8	6	125	15	7					
SNR/L0010K11	11NR/L□□	13	10	7.2	125	18	9		/	M2.5×7	T8	
SNR/L0012M11		16	12	8.7	150	18	11					
SNR/L0013M11		15	13	8	150	18	12					
SNR/L0016Q11	16NR/L□□	18	16	9.5	180	20	15		/	M3.5×10	T15	
SNR/L0013N16		17	13	10.2	160	25	12					
SNR/L0014N16		17	14	9.5	160	25	13					
SNR/L0016Q16	16NR/L□□	20	16	11.5	180	25	14.6		STM1603R/ STM1603L	M3.5×12	T15	
SNR/L0018Q16		21	18	11.5	180	25	16.8					
SNR/L0020R16		24	20	13.5	200	28	18.4					
SNR/L0025S16	22NR/L□□	29	25	16	250	32	23.4	STM22T3R/ STM22T3L	M4.5×14	T15		
SNR/L0032T16		36	32	19.5	300	38	30					
SNR/L0040T16		44	40	23.5	300	42	38					
SNR/L0050U16	22NR/L□□	54	50	28.5	350	50	48	STM22T3R/ STM22T3L	M4.5×14	T15		
SNR/L0020R22		24	20	13.5	200	32	18.4					
SNR/L0025S22		31	25	18	250	32	23.4					
SNR/L0032T22	22NR/L□□	38	32	21.5	300	38	30	STM22T3R/ STM22T3L	M4.5×14	T15		
SNR/L0040T22		46	40	25.5	300	42	38					
SNR/L0050U22		56	50	30.5	350	50	48					
MNR0032T27 (配压板)	27NR□□	38	32	21.5	300	38	30	STM27T3	M6X15	L3/T20		

▲更多型号可咨询, 可接受高要求非标定制

SUNR/L

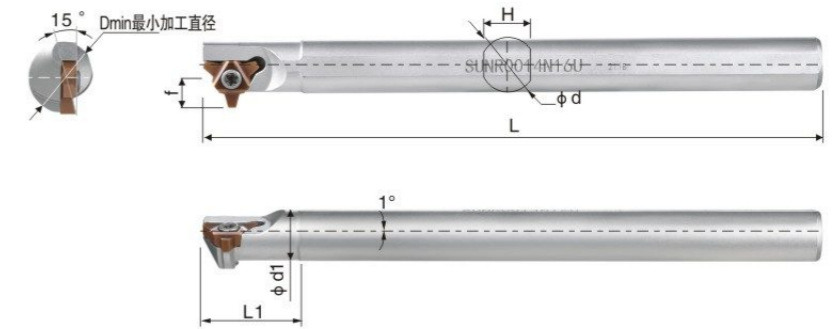
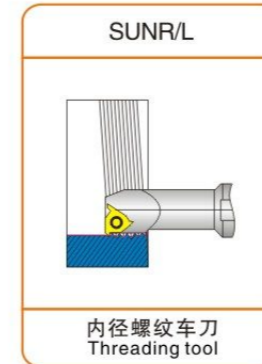

型号 Type	刀片 Blade	规格 Specification							螺丝 Screw	扳手 Wrench
		φDmin	φ d	F	L	L1	H	α°		
SUNR/L0008K11U	11UNR	11	8	6.1	125	15	7	15°	M2.5X6	T8
SUNR/L0010K11U		13	10	7.1	125	15	9			
SUNR/L0012M11U		15	12	8.1	150	15	11			
SUNR/L0012M16U	16UNR	16	12	9	150	25	11		M3.5X10	T15
SUNR/L0013N16U		17	13	9.5	160	27	12			
SUNR/L0014N16U		18	14	10	160	27	13			
SUNR/L0016Q16U	22UNR	20	16	11	180	27	14.8		M4.5X12	T20
SUNR/L0016Q22U		21	16	12.3	180	30	14.8			
SUNR/L0020R22U		25	20	14.3	200	30	18.4			
SUNR/L0025S22U		30	25	16.8	250	30	23.4			

▲更多型号可咨询, 可接受高要求非标定制

SMT

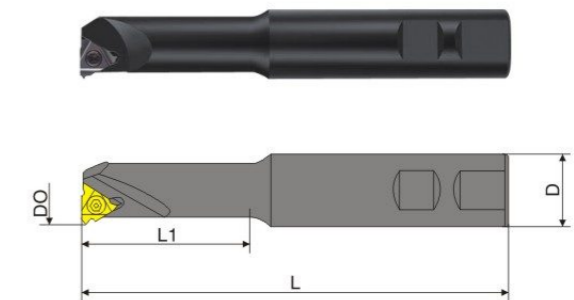
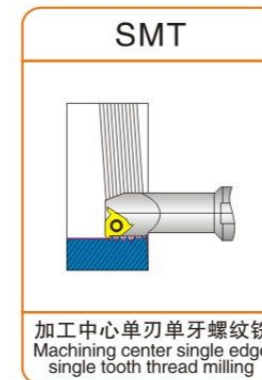

型号 Type	刀片 Blade		规格 Specification				螺丝 Screw	扳手 Wrench
	铣螺纹	铣槽	D0	L1	D	L		
SMT12-12F11	11NR**	T11N**	11	8	6.1	125	M2.5*8	T8
SMT18-20K16	16NR**	T16N**	13	10	7.1	125	M3.5*8	T15
SMT25-25M16			15	12	8.1	150		
SMT35-32S22	22NR**	T22N**	16	12	9	150	M5*12	T20

▲更多型号可咨询, 可接受高要求非标定制

SNR/L

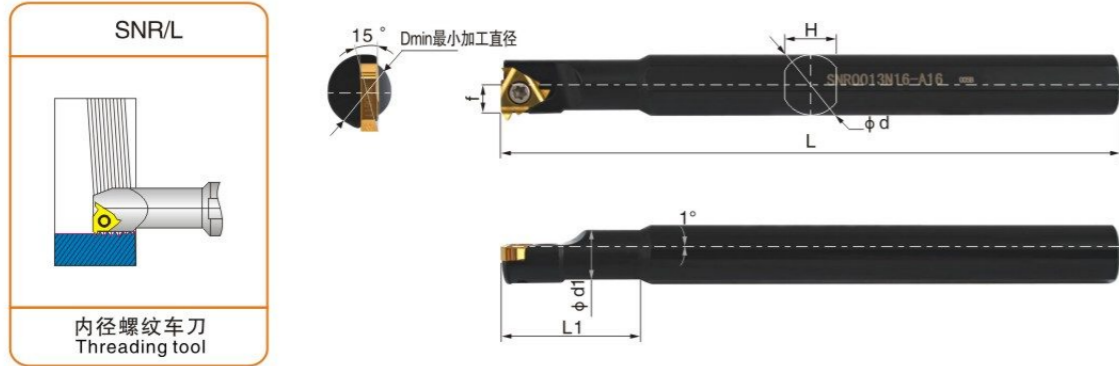

内径螺纹车刀 Threading tool

型号 Type	刀片 Blade	规格 Specification							螺丝 Screw	扳手 Wrench
		φ Dmin	φ d	f	L	L1	H	α°		
SNR/L0005K06-A12	06NR/L□□	7	16	4	125	13	14.6	15°	M2.0×6	T6
SNR/L0006K06-A16	06NR/L□□	8	16	4	125	18	14.6		M2.5×6	T8
SNR/L0008M08-A16	08NR/L□□	11	16	5.5	150	28	14.6		M2.5×6	T8
SNR/L0010K11-A16	11NR/L□□	13	16	7.2	125	28	14.6		M3.5×10	T15
SNR/L0012M11-A16	11NR/L□□	15	16	8.7	150	33	14.6		M2.5×6	T8
SNR/L0013N16-A16	16NR/L□□	17	16	10	160	33	14.6		M3.5×10	T15
SNR/L0010K11-A16	11NR/L□□	13	16	7.2	125	28	14.6		M2.5×6	T8
SNR/L0012M11-A16	11NR/L□□	15	16	8.7	150	33	14.6		M3.5×10	T15
SNR/L0013N16-A16	16NR/L□□	17	16	10	160	33	14.6		M3.5×10	T15

▲更多型号可咨询, 可接受高要求非标定制

CNR/L

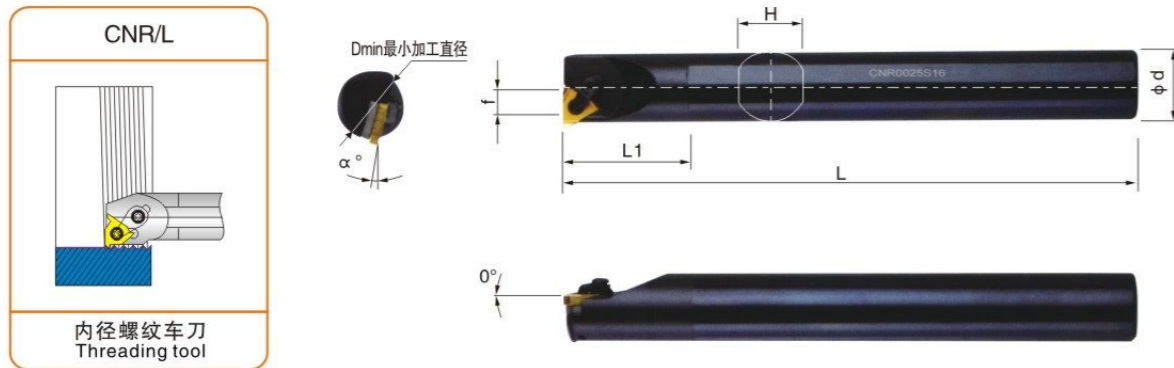

内径螺纹车刀 Threading tool

型号 Type	刀片 Blade	规格 Specification							垫片 Shim	螺丝 Screw	压板 Clamp	双头螺丝 Screw	扳手 Wrench						
		φ Dmin	φ d	f	L	L1	H	α°											
CNR/L0025S16	16NR/L□□	29	25	16	250	32	23.4	15°	STM1603R/STM1603L	M3.5×8	HL1808	ML618	T15 L2.5						
CNR/L0032T16		36	32	19.5	300	38	30												
CNR/L0040T16		44	40	23.5	300	42	38												
CNR/L0050U16		54	50	28.5	350	50	48												
CNR/L0025S22	22NR/L□□	31	25	18	250	32	23.4		15°	STM22T3R/STM22T3L		M4×11		HL1808	ML618	T15 L2.5			
CNR/L0032T22		38	32	21.5	300	38	30												
CNR/L0040T22		46	40	25.5	300	42	38												
CNR/L0050U22		56	50	30.5	350	50	48												
HCNR/L0025S16	16NR/L□□	29	25	16	250	32	23.4			15°		STM1603R/STM1603L			M3.5×8		HL1808	ML618	T15 L2.5
HCNR/L0032T16		36	32	19.5	300	38	30												
HCNR/L0040T16		44	40	23.5	300	42	38												
HCNR/L0050U16		54	50	28.5	350	50	48												
HCNR/L0025S22	22NR/L□□	31	25	18	250	32	23.4	15°			STM22T3R/STM22T3L	M4×11	HL1808		ML618			T15 L2.5	
HCNR/L0032T22		38	32	21.5	300	38	30												
HCNR/L0040T22		46	40	25.5	300	42	38												
HCNR/L0050U22		56	50	30.5	350	50	48												

▲更多型号可咨询, 可接受高要求非标定制

STTR/L

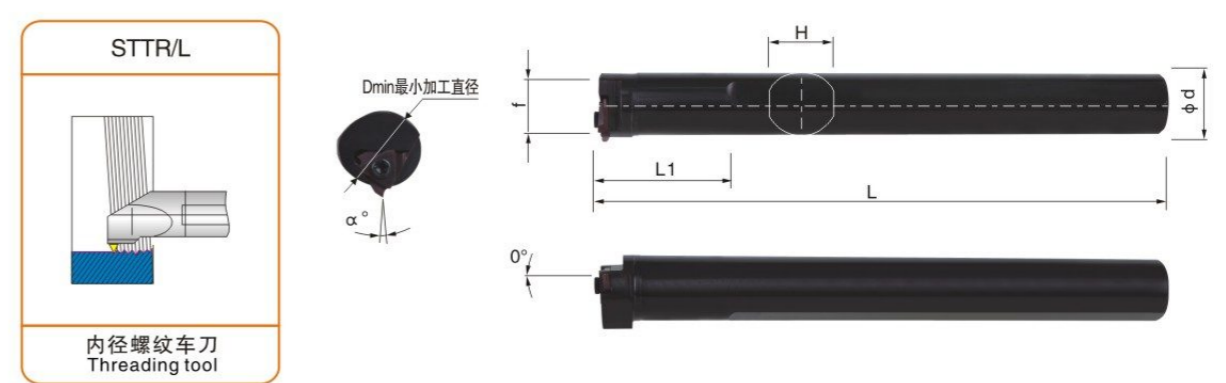

内径螺纹车刀 Threading tool

型号 Type	刀片 Blade	规格 Specification							螺丝 Screw	扳手 Wrench	
		φ Dmin	φ D	f	L	L1	H	α°			
STTR/L0020Q16	TT32/R/L	25	20	14.5	200	26	18.4	15°	M4×10	T15	
STTR/L0025S16		30	25	17.5	250	30	23.4				
STTR/L0032T16		38	32	22	300	35	30				
STTR/L0025S22	TT43R/L	31	25	18	250	32	23.4		M5×12	T20	
STTR/L0032T22		39	32	22.5	300	38	30				
HSTTR/L0020R16	TT32R/L	25	20	14.5	200	26	18.4		15°	M4×10	T15
HSTTR/L0025S16		30	25	17.5	250	30	23.4				
HSTTR/L0032T16		38	32	22	300	35	30				
HSTTR/L0025S22	TT43R/L	31	25	18	250	32	23.4			M5×12	T20
HSTTR/L0032T22		39	32	22.5	300	38	30				

▲更多型号可咨询, 可接受高要求非标定制

B-SER/L

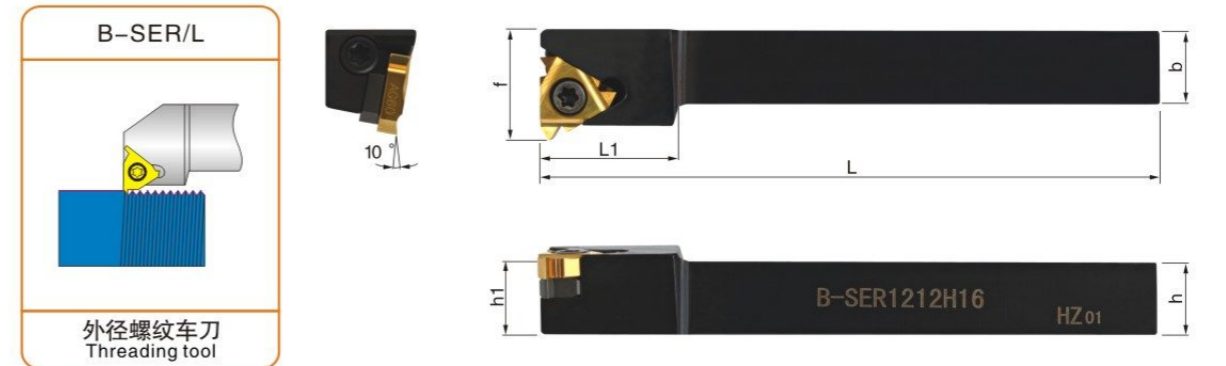

外径螺纹车刀 Threading tool

型号 Type	刀片 Blade	规格 Specification						垫片 Shim	螺丝 Screw	侧螺丝 Lateral screw	扳手 Wrench
		h	b	L	L1	h1	f				
B-SER/L1212H16	16ER/L□□	12	12	100	20	12	18	STM1603/STM1603L	M3.5×12	M3×8C	T15
B-SER/L1616H16		16	16	100	20	16	20				
B-SER/L2020K16		20	20	125	22	20	25				
B-SER/L2525M16		25	25	150	22	25	32				
B-SER/L2020K22	22ER/L□□	20	20	125	28	20	25	STM22T3	M4.5×12	M3×8C	T20
B-SER/L2525N22		25	25	150	28	25	30				
B-SER/L3232P22		32	32	170	28	32	40				

▲更多型号可咨询, 可接受高要求非标定制

SER/L

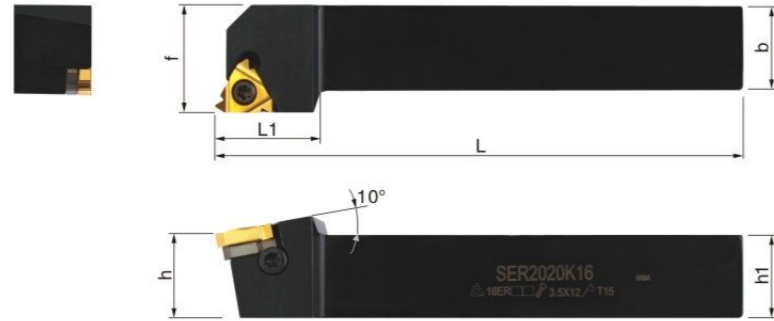
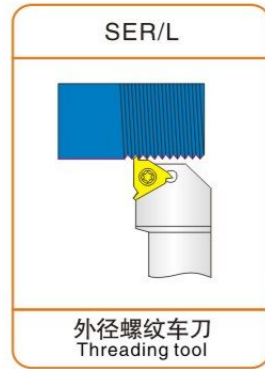

型号 Type	刀片 Blade	规格 Specification						压板 Clamp	垫片 Shim	螺丝 Screw	侧螺丝 Lateral screw	扳手 Wrench
		h	b	L	L1	h1	f					
SER/L1010H11	11ER/L□□	10	10	100	16	10	12			M2.5×6		T8
SER/L1212H11		12	12	100	16	12	16					
SER/L1616H11	11NR/L□□	16	16	100	20	16	20					
SER/L1212H16		12	12	100	20	12	18					
SER/L1616H16	16ER/L□□	16	16	100	20	16	20	STM1603R/ STM1603L	M3.5×12	M3×8C		T15
SER/L2020K16		20	20	125	22	20	25					
SER/K2525M16		25	25	150	22	25	32					
SER/L3232P16		32	32	170	25	32	32					
SER/L2020K22	22ER/L□□	20	20	125	26	20	32	STM22T3/ STM22T3L	M4.5×14	M3×8C		
SER/L2525M22		25	25	150	26	25	32					
SER/L3232P22	27ER/L□□	32	32	170	28	32	32	HL1813	STM2704	M6×16	M3×8C	T15 T20 L3
MER2525M27		25	25	150	36	25	32					
MER3232P27		32	32	170	36	32	40					

▲更多型号可咨询，可接受高要求非标定制

CER/L

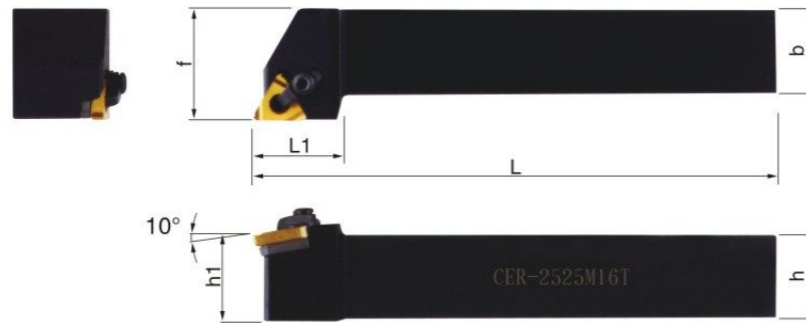
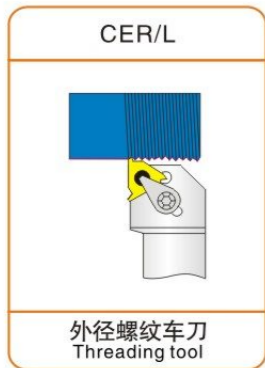

型号 Type	刀片 Blade	规格 Specification						垫片 Shim	螺丝 Screw	压板 Clamp	双头螺丝 Screw	扳手 Wrench
		h	b	L	L1	h1	f					
CER/L1616H16	16ER/L□□	16	16	100	20	16	20	STM1603R/ STM1603L	M3.5×12	HL1808	ML0520	T15 L2.5
CER/L2020K16		20	20	125	22	20	25					
CER/L2525M16		25	25	150	22	25	32					
CER/L3225P16		32	32	170	25	32	32					
CER/L2525M22	22ER/L□□	25	25	150	26	25	32	STM22T3R/ STM22T3L	M4×14			
CER/L3225P22		32	32	170	28	32	32					

▲更多型号可咨询，可接受高要求非标定制

SER/L

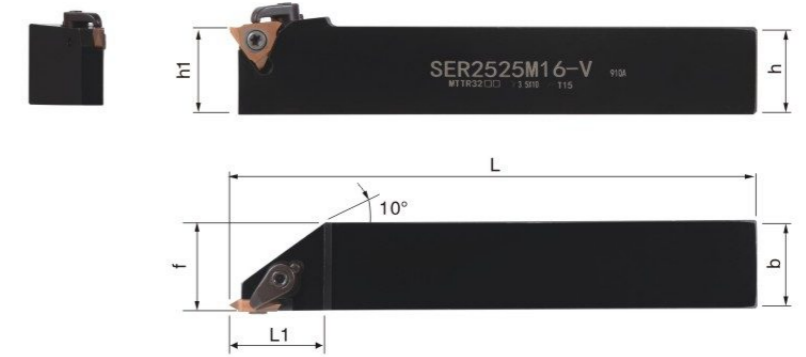
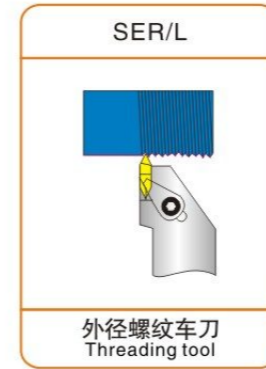

型号 Type	刀片 Blade	规格 Specification					压板 Clamp	双头螺丝 Screw	螺丝 Screw	扳手 Wrench
		h	b	L	h1	f				
SER1212H16-V	MTTR32□□	12	12	100	12	12	HL1808	MI0520		T15 L2.5
SER1616H16-V		16	16	100	16	16				
SER2020K16-V		20	20	125	20	20				
SER2525M16-V		25	25	150	25	25				
KER1010H16-V	MTTR32□□	10	10	100	10	10	/	/	M4X10	T15
KER1212H16-V		12	12	100	12	12				
KER1616H16-V		16	16	100	16	16				
KER2020K16-V		20	20	125	20	20				
KER2525M16-V	MTTR43□□	25	25	150	25	25	HL1808	ML0520	M4.5X12	T20 L2.5
SER2020K22-V		20	20	125	20	20				
SER2525M22-V		25	25	150	25	25				
SER3232P22-V		32	32	170	32	32				
KER2020K22-V	MTTR43□□	20	20	125	20	20	/	/	M4.5X12	T20
KER2525M22-V		25	25	150	25	25				
KER3232P22-V		32	32	170	32	32				
SER2525M27-V-6		27VER(厚度6.35)	25	25	150	25				
SER3232P27-V-6	32		32	170	32	32				
SER2525M27-V-8	27VER(厚度8.75)	25	25	150	25	25	HL1813	/	M6X16	T20 L3
SER3232P27-V-8		32	32	170	32	32				
SER2525M27-V-10	27VER(厚度10.2)	25	25	150	25	25	HL1813	/	M6X16	T20 L3
SER3232P27-V-10		32	32	170	32	32				

▲更多型号可咨询，可接受高要求非标定制

CTTR/L

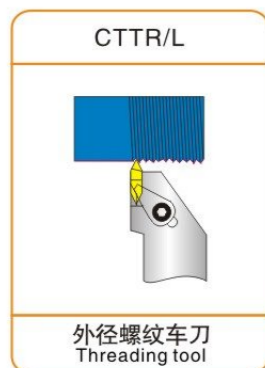

型号 Type	刀片 Blade	规格 Specification						螺丝 Screw	压板 Clamp	双头螺丝 Screw	扳手 Wrench
		h	b	L	L1	h1	f				
CTTR/L1010F16	TT32ER/L□□	10	10	90	20	10	12	M4 x 10	HL1808	ML0520	T15 L2.5
CTTR/L1212H16		12	12	100	20	12	16				
CTTR/L1616H16		16	16	100	20	16	20				
CTTR/L2020K16		20	20	125	22	20	25				
CTTR/L2020K22	TT43ER/L□□	20	20	125	28	20	25	M5 x 12	HL1808	ML0520	T20 L2.5
CTTR/L2525M22		25	25	150	30	25	32				
CTTR/L3232P22		32	32	170	30	32	40				

▲更多型号可咨询, 可接受高要求非标定制

KTTXR

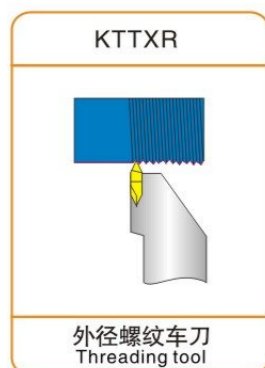

型号 Type	刀片 Blade	规格 Specification						螺丝 Screw	扳手 Wrench
		h	b	L	L1	h1	f		
KTTXR1010F16	TT32ER/L□□	10	10	90	20	10	12	M4 x 10	T15
KTTXR1212H16		12	12	100	20	12	16		
KTTXR1616H16		16	16	100	20	16	20		
KTTXR2020K16		20	20	125	22	20	25		
KTTXR2020K22	TT43ER/L□□	20	20	125	28	20	25	M5 x 12	T20
KTTXR2525M22		25	25	150	30	25	32		
KTTXR3232P22		32	32	170	30	32	40		

▲更多型号可咨询, 可接受高要求非标定制

SVNR

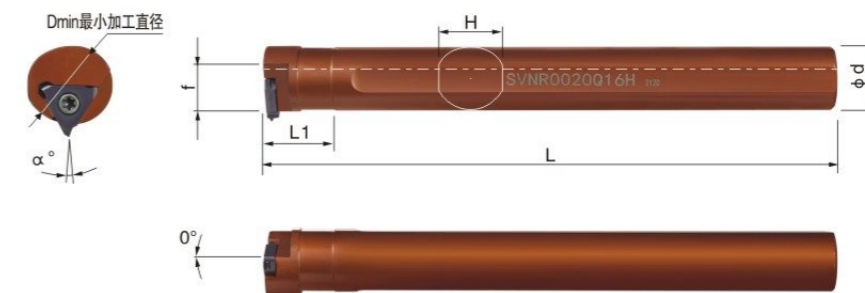
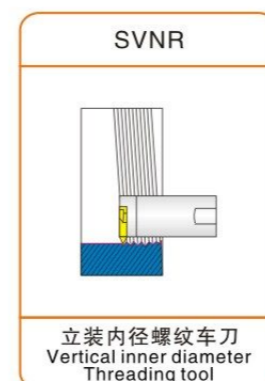

型号 Type	刀片 Blade	规格 Specification					螺丝 Screw	压板 Clamp	扳手 Wrench
		ΦD	F	L	L1	H			
SVNR0016N16	16VEL	16	19	160	30	14.8	M3.5X10	HL1808	T15
SVNR0020Q16		20	23	180	30	18.4			
SVNR0025R16		25	28	200	40	23.4			
SVNR0025R22	22VEL	25	31	200	30	23	M4.5X12	HL1813	T20
SVNR0032T22		32	37	300	30	30			
SVNR0032T27-6	27VEL(厚度6.35)	32	39	300	35	30	M6X16	HL1813	T20 L3
SVNR0040T27-6		40	46	300	35	38			
SVNR0032T27-8	27VEL(厚度8.75)	32	39	300	35	30			
SVNR0040T27-8		40	46	300	35	38			
SVNR0032T27-10	27VEL(厚度10.2)	32	39	300	35	30			
SVNR0040T27-10		40	46	300	35	38			

▲更多型号可咨询, 可接受高要求非标定制

切槽刀系列

Slotting tool

www.wencerl.com

ZQ□□R/L

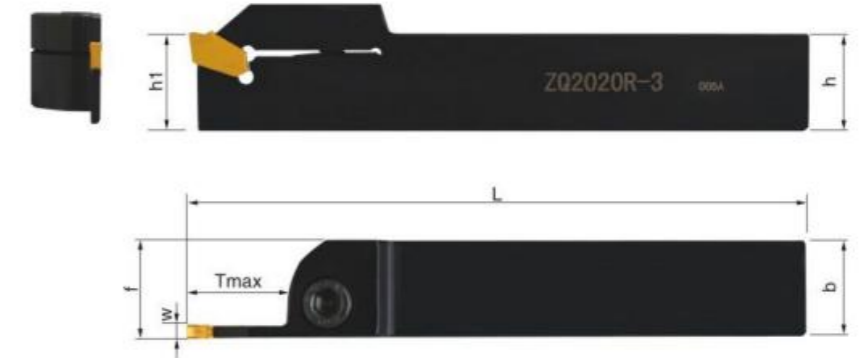
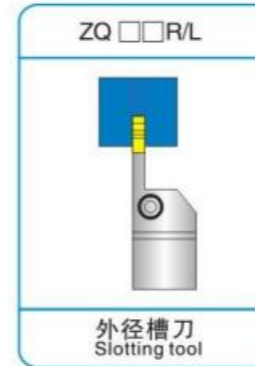

型号 Type	刀片 Blade	规格 Specification							螺丝 Screw	扳手 Wrench
		w	b	h	L	h1	f	Tmax		
ZQ1616R/L-02	ZQMX2N11-1E SP200	2	16	16	100	16	16.3	16	M5×20	L4
ZQ2020R/L-02		2	20	20	125	20	20.3	16		
ZQ2525R/L-02		2	25	25	150	25	25.3	16		
ZQ1616R/L-03	ZQMX3N11-1E SP300	3.125	16	16	100	16	16.4	20	M6×20	L5
ZQ2020R/L-03		3.125	20	20	125	20	20.4	20		
ZQ2525R/L-03		3.125	25	25	150	25	25.4	20		
ZQ3225R/L-03		3.125	25	32	170	32	25.4	25		
ZQ1616R/L-04	ZQMX4N11-1E SP400	4.125	16	16	100	16	16.4	20	M5×20	L4
ZQ2020R/L-04		4.125	20	20	125	20	20.4	20		
ZQ2525R/L-04		4.125	25	25	150	25	25.4	20		
ZQ3225R/L-04		4.125	32	32	170	32	25.4	25		
ZQ2020R/L-05	ZQMX5N11-1E SP500	5.125	20	20	125	20	20.5	25	M6×22	L5
ZQ2525R/L-05		5.125	25	25	150	25	25.5	25		
ZQ3232R/L-05		5.125	32	32	170	32	32.5	25		
ZQ2525R/L-06	ZQMX6N11-1E SP600	6.4	25	25	150	25	25.5	32		
ZQ3232R/L-06		6.4	32	32	170	32	32.5	32		

▲更多型号可咨询，可接受高要求非标定制

专利产品 专利号: 2L2013 2 0320 273.5

MGEHR/L □□

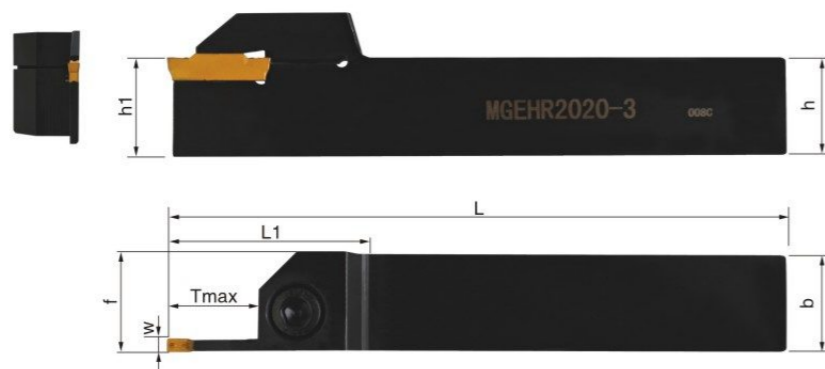
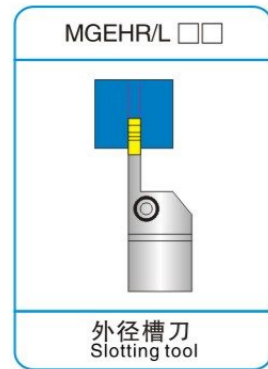

MGEHR/L □□(加长切深)

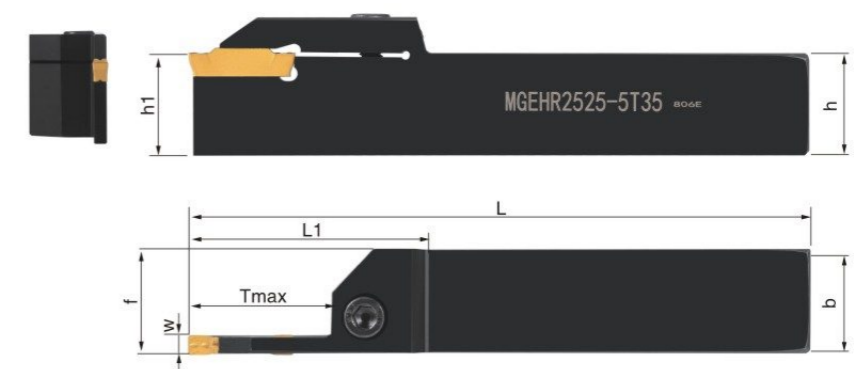
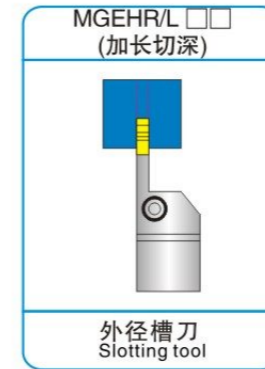

型号 Type	刀片 Blade	规格 Specification							螺丝 Screw	扳手 Wrench
		w	b	h	L	h1	f	Tmax		
MGEHR/L1010-1.5	MGMN150-M	1.5	10	10	100	10	10	15	M4 × 16	L3
MGEHR/L1212-1.5			12	12	100	12	12	15	M4 × 16	
MGEHR/L1616-1.5			16	16	100	16	16	15	M5 × 20	
MGEHR/L2020-1.5			20	20	125	20	20	15	M6 × 20	
MGEHR/L2525-1.5			25	25	150	25	25	15	M6 × 20	
MGEHR/L1010-2	MGMN200-M	2	10	10	100	10	10	16	M4 × 16	L3
MGEHR/L1212-2			12	12	100	12	12	16	M4 × 16	
MGEHR/L1616-2			16	16	100	16	16	16	M5 × 20	
MGEHR/L2020-2			20	20	125	20	20	16	M6 × 20	
MGEHR/L2525-2			25	25	150	25	25	16	M6 × 20	
MGEHR/L1616-2.5	MGMN250-M	2.5	16	16	100	16	16	17	M5 × 20	L4
MGEHR/L2020-2.5			20	20	125	20	20	17	M6 × 20	
MGEHR/L2525-2.5			25	25	150	25	25	17	M6 × 20	
MGEHR/L1212-3	MGMN300-M	3	12	12	100	12	12	20	M4 × 16	L3
MGEHR/L1616-3	MGMN300-M MGGN300-M MRMN300-M	3	16	16	100	16	16	20	M5 × 20	L4
MGEHR/L2020-3			20	20	125	20	20	20	M6 × 20	
MGEHR/L2525-3			25	25	150	25	25	20	M6 × 20	
MGEHR/L3232-3			32	32	170	32	32	20	M6 × 20	
MGEHR/L1616-4	MGMN400-M MGGN400-M MRMN400-M	4	16	16	100	16	16	20	M5 × 20	L4
MGEHR/L2020-4			20	20	125	20	20	20	M6 × 20	
MGEHR/L2525-4			25	25	150	25	25	20	M6 × 20	
MGEHR/L3232-4			32	32	170	32	32	20	M6 × 20	
MGEHR/L2020-5	MGMN500-M MGGN500-M MRMN500-M	5	20	20	125	20	20	25	M6 × 20	L5
MGEHR/L2525-5			25	25	150	25	25	25		
MGEHR/L3232-5			32	32	170	32	32	25		
MGEHR/L2020-6	MGMN600-M MGGN600-M MRMN600-M	6	20	20	125	20	20	25	M6 × 20	L5
MGEHR/L2525-6			25	25	150	25	25	25		
MGEHR/L3232-6			32	32	170	32	32	25		
MGEHR/L2525-8	MGMN800-M MGGN800-M MRMN800-M	8	25	25	150	25	25	28	M6 × 20	L5
MGEHR/L3232-8			32	32	170	32	32	28		

▲更多型号可咨询, 可接受高要求非标定制

型号 Type	刀片 Blade	规格 Specification							螺丝 Screw	扳手 Wrench
		w	b	h	L	h1	f	Tmax		
MGEHR/L2020-3T25	MGMN300-M MGGN300-M MRMN300-M	3	20	20	125	20	20	25	M6 × 20	L5
MGEHR/L2525-3T25			25	25	150	25	25	25		
MGEHR/L3232-3T25			32	32	170	32	32	25		
MGEHR/L2020-4T30	MGMN400-M MGGN400-M MRMN400-M	4	20	20	125	20	20	30	M6 × 20	L5
MGEHR/L2525-4T30			25	25	150	25	25	30		
MGEHR/L3232-4T30			32	32	170	32	32	30		
MGEHR/L2525-5T35	MGMN500-M MGGN500-M MRMN500-M	5	25	25	150	25	25	35	M6 × 20	L5
MGEHR/L3232-5T35			32	32	170	32	32	35		

▲更多型号可咨询, 可接受高要求非标定制

CGWSR/L(东芝槽型)

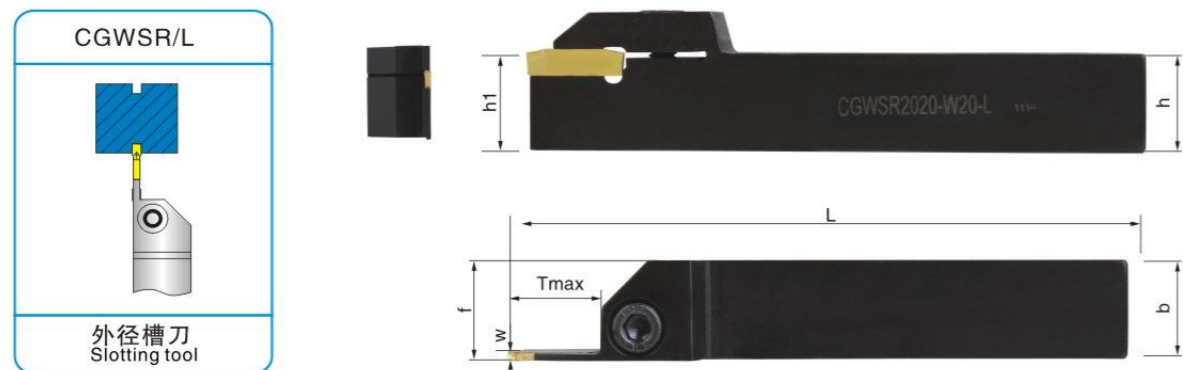

型号 Type	刀片 Blade	规格 Specification							螺丝 Screw	扳手 Wrench
		w	b	h	L	h1	f	Tmax		
CGWSR/L1616-W20-L	WGE20	2	16	16	100	16	16.23	20	M5 x 20	L4
CGWSR/L2020-W20-L		2	20	20	125	20	20.23	20		
CGWSR/L2525-W20-L		2	25	25	150	25	25.23	20		
CGWSR/L1616-W30-L	WGE30	3	16	16	100	16	16.35	20	M5 x 20	L4
CGWSR/L2020-W30-L		3	20	20	125	20	20.35	20		
CGWSR/L2525-W30-L		3	25	25	150	25	25.35	20		
CGWSR/L2020-W40-L	WGE40	4	20	20	125	20	20.5	23	M6 x 20	L5
CGWSR/L2525-W40-L		4	25	25	150	25	25.5	23		
CGWSR/L2525-W50-L	WGE50	5	25	25	150	25	25.5	25.5	M6 x 20	L5

▲更多型号可咨询, 可接受高要求非标定制

QE□DR/L(株洲槽型)

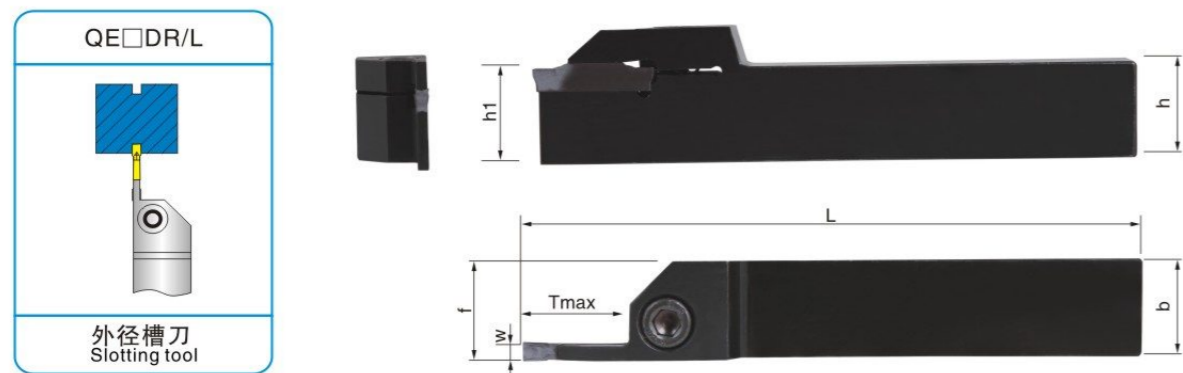

型号 Type	刀片 Blade	规格 Specification							螺丝 Screw	扳手 Wrench
		w	b	h	L	h1	f	Tmax		
QECD1616R/L15-2	Z□BD02□□	2	16	16	100	16	16.2	15	M5 x 20	L4
QECD2020R/L15-2		2	20	20	125	20	20.2	15		
QEFD2020R/L17-3	Z□FD03□□	3	20	20	125	20	20.3	17	M6 x 20	L5
QEFD2525R/L17-3		3	25	25	150	25	25.3	17		
QEGD2020R/L22-4	Z□GD04□□	4	20	20	125	20	20.5	22	M6 x 20	L5
QEGD2525R/L22-4		4	25	25	150	25	25.5	22		
QEHD2525R/L22-5	Z□GD05□□	5	25	25	150	25	25.5	22	M6 x 20	L5

▲更多型号可咨询, 可接受高要求非标定制

R-MGEHR/L

专利产品 专利号: 2L2013 2 0320 289.6

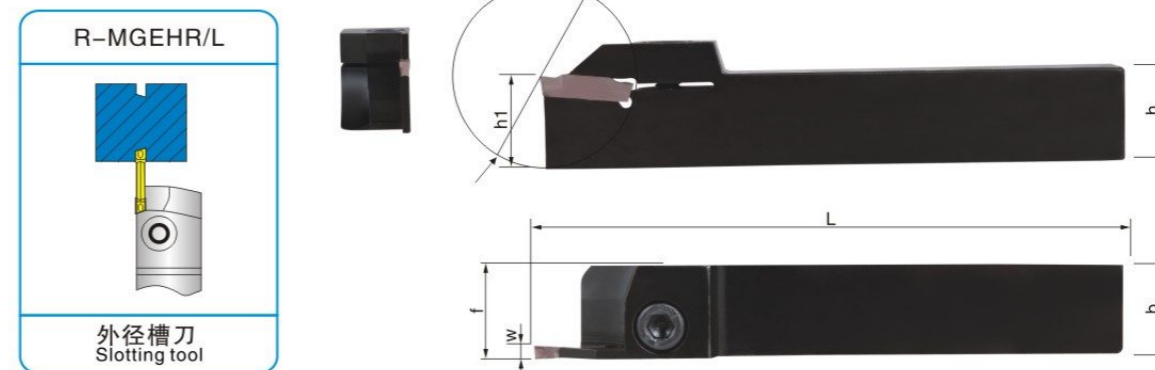

型号 Type	刀片 Blade	规格 Specification							螺丝 Screw	扳手 Wrench
		w	b	h	L	h1	f	Dmax		
MGEHR/L1616-2R	MGMN200	2	16	16	100	16	16.2	32	M5 x 20	L4
MGEHR/L2020-2R		2	20	20	125	20	20.2	32		
MGEHR/L1616-2.5R	MGMN250	2.5	16	16	100	16	16.3	34	M5 x 20	L4
MGEHR/L2020-2.5R		2.5	20	20	125	20	20.3	34		
MGEHR/L1616-3R	MGMN300	3	16	16	100	16	16.35	40	M5 x 20	L4
MGEHR/L2020-3R		3	20	20	125	20	20.35	40		

▲更多型号可咨询, 可接受高要求非标定制

TTER/L(特固克槽型)

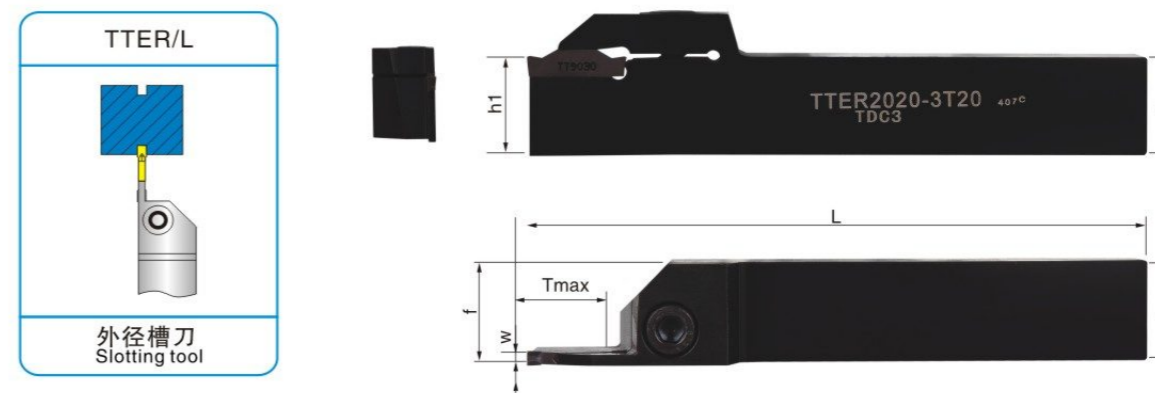

型号 Type	刀片 Blade	规格 Specification							螺丝 Screw	扳手 Wrench
		w	b	h	L	h1	f	Tmax		
TTER/L1212-2T17	TDC2	2	12	12	100	12	12.2	17	M4 x 16	L3
TTER/L1616-2T17		2	16	16	100	16	16.2	17		
TTER/L2020-2T17		2	20	20	125	20	20.2	17	M6 x 20	L5
TTER/L2525-2T17		2	25	25	150	25	25.2	17		
TTER/L1616-3T20	TDC3	3	16	16	100	16	16.4	20	M5 x 20	L4
TTER/L2020-3T20		3	20	20	125	20	20.4	20		
TTER/L2525-3T20	TDC4	3	25	25	150	25	25.4	20	M6 x 20	L5
TTER/L1616-4T25		4	16	16	100	16	16.5	25		
TTER/L2020-4T25	TDC5	4	20	20	125	20	20.5	25	M5 x 20	L4
TTER/L2525-4T25		4	25	25	150	25	25.5	25		
TTER/L2020-5T25	TDC5	5	20	20	125	20	20.5	25	M6 x 20	L5
TTER/L2525-5T25		5	25	25	150	25	25.5	25		

▲更多型号可咨询, 可接受高要求非标定制

KGMR/L(京瓷槽型)

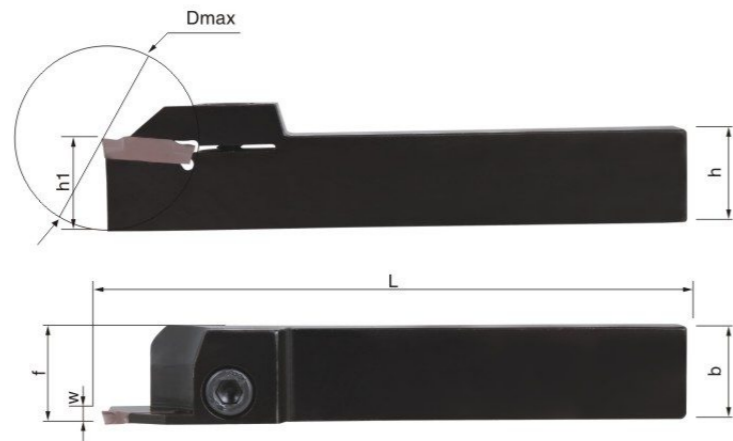
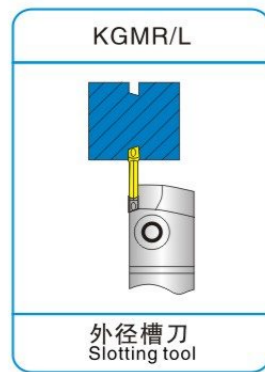

型号 Type	刀片 Blade	规格 Specification							螺丝 Screw	扳手 Wrench
		w	b	h	L	h1	f	Dmax		
KGMR/L1010F-1.5-85	GMM1520-MT	1.5	10	10	85	10	10.2	20	M4 x 12	T15
KGMR/L1212F-1.5-85		1.5	12	12	85	12	12.2	25		
KGMR/L1616H-1.5T15		1.5	16	16	100	16	16.3	30	M5 x 16	L4
KGMR/L2020K-1.5T15		1.5	20	20	125	20	20.3	30	M6 x 20	L5
KGMR/L1010F-2-85	GMM2020-MT	2	10	10	85	10	10.3	20	M4 x 12	T15
KGMR/L1212F-2-85	GMM2020-MT GMM2020R/L-MT	2	12	12	85	12	12.3	25	M4 x 12	T15
KGMR/L1616H-2T17		2	16	16	100	16	16.3	35	M5 x 16	L4
KGMR/L2020K-2T17	GMM2020-MT	2	20	20	125	20	20.3	35	M5 x 20	L5
KGMR/L2525M-2T17		2	25	25	150	25	25.3	35		
KGMR/L1616H-2.5T18	GMM2520-MT	2.5	16	16	100	16	16.3	36	M5 x 16	L4
KGMR/L2020K-2.5T18		2.5	20	20	125	20	20.3	36	M6 x 20	L5
KGMR/L1212F-3-85	GMM3020-MT GMM3020R/L-MT	3	12	12	85	12	12.4	25	M4 x 12	T15
KGMR/L1616H-3T20		3	16	16	100	16	16.4	40	M5 x 16	L4
KGMR/L2020K-3T20		3	20	20	125	20	20.4	40	M6 x 20	L5
KGMR/L2525M-3T20	GMM3020-MT	3	25	25	150	25	25.4	40	M5 x 20	L5
KGMR/L2020K-4T20	GMM4020-MT	4	20	20	125	20	20.4	40		
KGMR/L2525M-4T20		4	25	25	150	25	25.4	40		
KGMR/L2020K-5T25	GMM5020-MT	5	20	20	125	20	20.5	50		
KGMR/L2525M-5T25		5	25	25	150	25	25.5	50		

▲更多型号可咨询, 可接受高要求非标定制

R/L123□□(山特维克槽型)

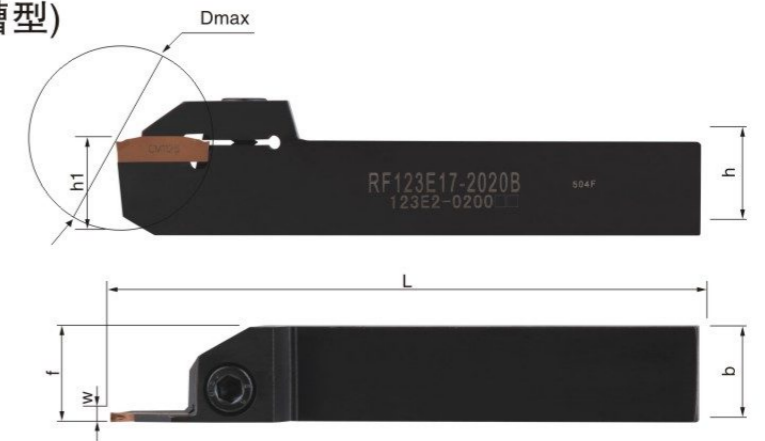
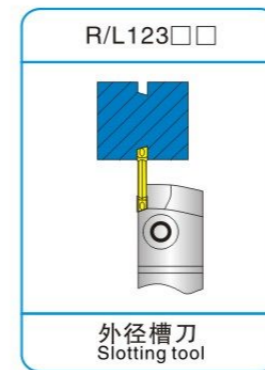

型号 Type	刀片 Blade	规格 Specification							螺丝 Screw	扳手 Wrench
		W	b	h	L	h1	f	Tmax		
RF123E17-1616B	N123E2□□	2	16	16	100	16	16.2	17	M5 x 20	L4
RF123E17-2020B		2	20	20	125	20	20.2	17	M6 x 20	L5
RF123E17-2525B		2	25	25	150	25	25.2	17	M6 x 20	L5
RF123G20-1616B	N123G2□□	3	16	16	100	16	16.2	20	M5 x 20	L4
RF123G20-2020B		3	20	20	125	20	20.2	20	M6 x 20	L5
RF123G20-2525B		3	25	25	150	25	25.2	20	M6 x 20	L5
RF123H25-1616B	N123H2□□	4	16	16	100	16	16.2	25	M5 x 20	L4
RF123H25-2020B		4	20	20	125	20	20.2	25	M6 x 20	L5
RF123H25-2525B		4	25	25	150	25	25.2	25	M6 x 20	L5

▲更多型号可咨询, 可接受高要求非标定制

DGTR/L□□(伊斯卡槽型)

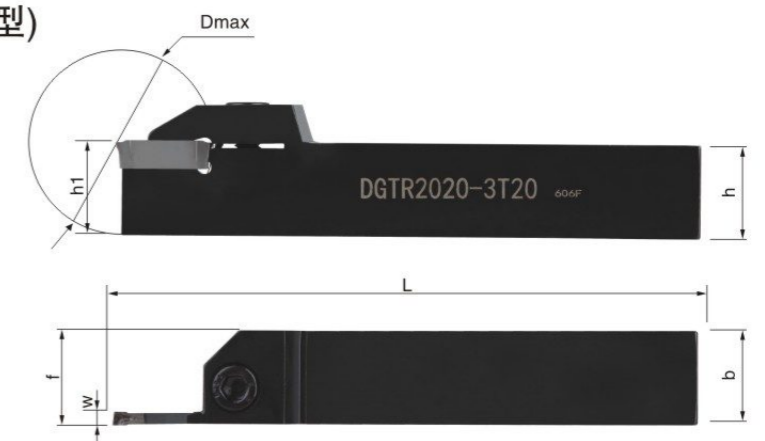
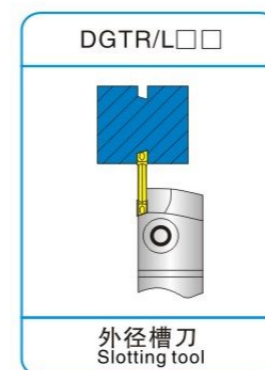

型号 Type	刀片 Blade	规格 Specification							螺丝 Screw	扳手 Wrench
		W	b	h	L	h1	f	Tmax		
DGTR1616-2T18	DGN2202C	2	16	16	100	16	16.2	18	M5 x 20	L4
DGTR2020-2T18		2	20	20	125	20	20.2	18	M6 x 20	L5
DGTR2525-2T18		2	25	25	150	25	25.2	18	M6 x 20	L5
DGTR1616-3T20	DGN3002C	3	16	16	100	16	16.2	20	M5 x 20	L4
DGTR2020-3T20		3	20	20	125	20	20.2	20	M6 x 20	L5
DGTR2525-3T20		3	25	25	150	25	25.2	25	M6 x 20	L5

▲更多型号可咨询, 可接受高要求非标定制

■ A4SMR/L(肯纳槽型)

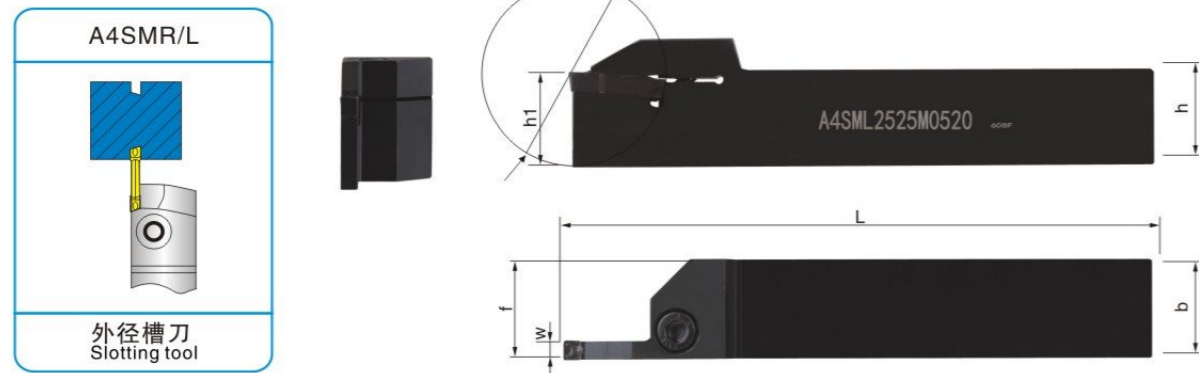

型号 Type	刀片 Blade	规格 Specification							螺丝 Screw	扳手 Wrench
		W	b	h	L	h1	f	Tmax		
A4SMR/L2020K0317	A4G0300M3□□ A4G0305M3□□	3	20	20	125	20	20.3	17	M6 × 20	L5
A4SMR/L2525K0317		3	25	25	150	25	25.3	17		
A4SMR/L3232P0317		3	32	32	170	32	32.3	17		
A4SMR/L2020K0417	A4G0400M4□□ A4G0405M4□□	4	20	20	125	20	20.3	17		
A4SMR/L2525M0417		4	25	25	150	25	25.3	17		
A4SMR/L3232P0417		4	32	32	170	32	32.3	17		
A4SMR/L2020K0520	AG0500M5□□ AG0505M5□□	5	20	20	125	20	20.3	20		
A4SMR/L2525M0520		5	25	25	150	25	25.3	20		
A4SMR/L3232P0520		5	32	32	170	32	32.3	20		

▲更多型号可咨询, 可接受高要求非标定制

■ GNDLR/L(住友槽型)

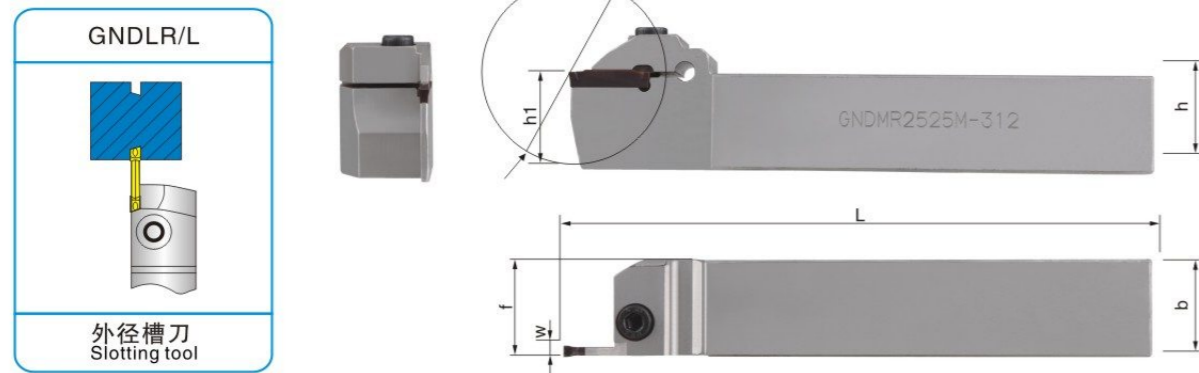

型号 Type	刀片 Blade	规格 Specification							螺丝 Screw	扳手 Wrench
		W	b	h	L	h1	f	Tmax		
GNDLR/L2020K-216	GCMN2002-GG	2	20	20	125	20	20.3	16	M6 × 20	L5
GNDLR/L2525M-216		2	25	25	150	25	25.3	16		
GNDLR/L3232P-216		2	32	32	170	32	32.3	16		
GNDLR/L2020K-320	GCMN3002-GG	3	20	20	125	20	20.3	20		
GNDLR/L2525M-320		3	25	25	150	25	25.3	20		
GNDLR/L3232P-320		3	32	32	170	32	32.3	20		
GNDLR/L2020K-425	GCMN4002-GG	4	20	20	125	20	20.3	25		
GNDLR/L2525M-425		4	25	25	150	25	25.3	25		
GNDLR/L3232P-425		4	32	32	170	32	32.3	25		

▲更多型号可咨询, 可接受高要求非标定制

■ GYHR(三菱槽型)

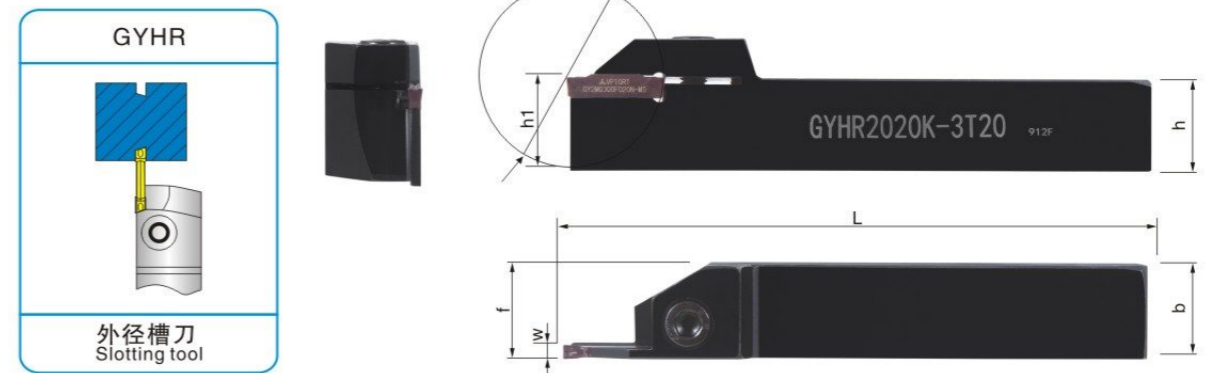

型号 Type	刀片 Blade	规格 Specification							螺丝 Screw	扳手 Wrench			
		W	b	h	L	h1	f	Tmax (切深)			Dmax		
GYHR1616H-2T18	GY2M0200□□-MM	2	16	16	100	16	16.2	18	50	M5 × 20	L4		
GYHR2020K-2T18		2	20	20	125	20	20.2	18	60	M6 × 20	L5		
GYHR2020K-3T20	GY2M0300□□-MM	3	20	20	125	20	20.2	20	60				
GYHR2525M-3T20		3	25	25	150	25	25.2	20	80				
GYHR2020K-4T25		GY2M0300□□-MM	4	20	20	125	20	20.2	25			60	
GYHR2525M-4T25	4		25	25	150	25	25.2	25	80				
GYHR2525M-5T25	GY2M0200□□-MM	5	25	25	150	25	25.2	25	80				

▲更多型号可咨询, 可接受高要求非标定制

MGEVR/L

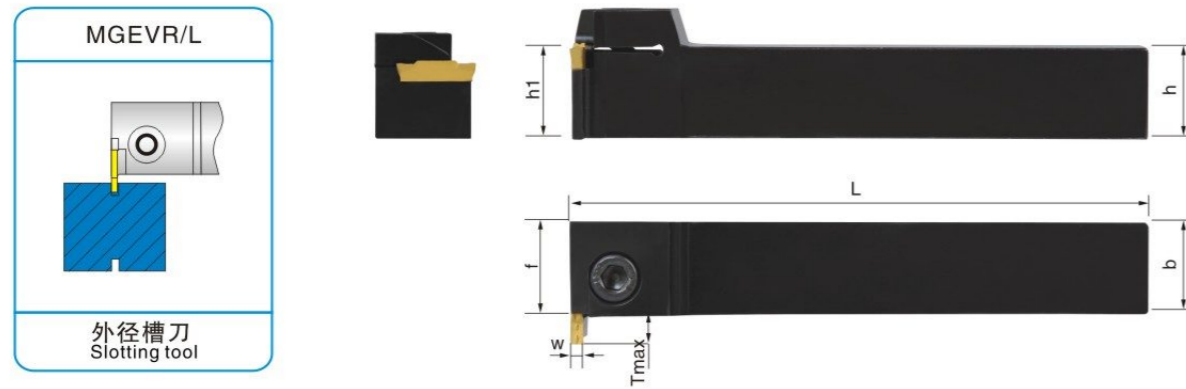

型号 Type	刀片 Blade	规格 Specification							螺丝 Screw	扳手 Wrench
		w	b	h	L	h1	f	Tmax		
MGEVR/L1616-1.5	MGMN150-M	1.5	16	16	100	16	21.3	5	M5 x 20	L4
MGEVR/L2020-1.5		1.5	20	20	125	20	26.3	6	M6 x 20	L5
MGEVR/L2525-1.5		1.5	25	25	150	25	33	6	M6 x 20	
MGEVR/L1616-2	MGMN200	2	16	16	100	16	21.3	5	M5 x 20	L4
MGEVR/L2020-2		2	20	20	125	20	26.3	6	M6 x 20	L5
MGEVR/L2525-2		2	25	25	150	25	33	6	M6 x 20	
MGEVR/L1616-2.5	MGMN250	2.5	16	16	100	16	21.3	5	M5 x 20	L4
MGEVR/L2020-2.5		2.5	20	20	125	20	26.3	6	M6 x 20	L5
MGEVR/L2525-2.5		2.5	25	25	150	25	33	7	M6 x 20	
MGEVR/L1616-3	MGMN300	3	16	16	100	16	24	7	M5 x 20	L4
MGEVR/L2020-3		3	20	20	125	20	26.5	6	M6 x 20	L5
MGEVR/L2525-3		3	25	25	150	25	33	7	M6 x 20	
MGEVR/L1616-4	MGMN400-M	4	16	16	100	16	21.3	7	M5 x 20	L4
MGEVR/L2020-4		4	20	20	125	20	26.3	6	M6 x 20	L5
MGEVR/L2525-4		4	25	25	150	25	33	7	M6 x 20	
MGEVR/L1616-1.5T8	MGMN150	1.5	16	16	100	16	24	8	M6X18	L5
MGEVR/L1616-2T10	MGMN200	2	16	16	100	16	26	10	M6X18	
MGEVR/L2020-2T12		2	20	20	125	20	32	12	M6X20	
MGEVR/L2525-2T15		2	25	25	150	25	40	15	M6X20	
MGEVR/L1616-3T10	MGMN300	3	16	16	100	16	26	10	M6X18	
MGEVR/L2020-3T12		3	20	20	125	20	32	12	M6X20	
MGEVR/L2525-3T15		3	25	25	150	25	40	15	M6X20	
MGEVR/L1616-4T10	MGMN400	4	16	16	100	16	26	10	M6X18	
MGEVR/L2020-4T12		4	20	20	125	20	32	12	M6X20	
MGEVR/L2525-4T15		4	25	25	150	25	40	15	M6X20	

▲更多型号可咨询, 可接受高要求非标定制

MGEUR (退刀槽加工用)

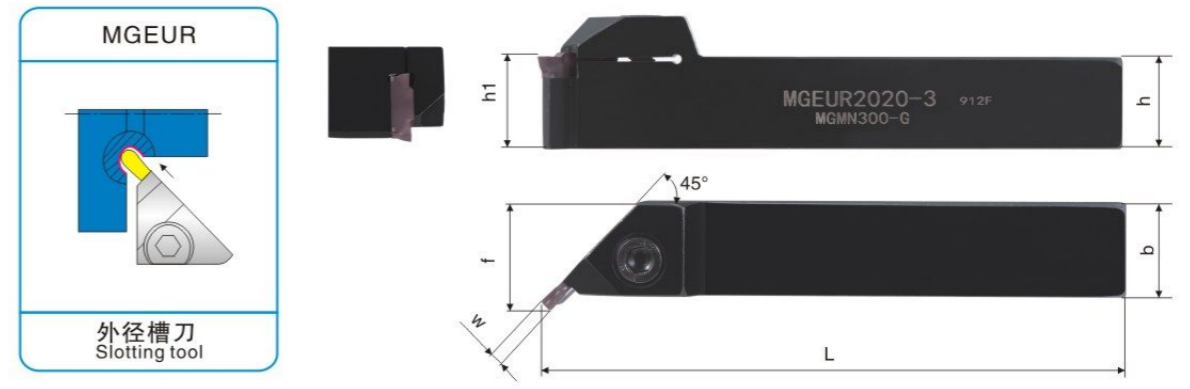

型号 Type	刀片 Blade	规格 Specification						螺丝 Screw	扳手 Wrench
		W	b	h	L	h1	f		
MGEUR2020-2	MGMN200-M	2	20	20	125	16	16.2	M6 x 20	L5
MGEUR2525-2		2	25	25	150	20	20.2		
MGEUR2020-3	MGMN300-M	3	20	20	125	20	20.2		
MGEUR2525-3		3	25	25	150	25	25.2		
MGEUR2020-4	MGMN400-M	4	20	20	125	20	20.2		
MGEUR2525-4		4	25	25	150	25	25.2		

▲更多型号可咨询, 可接受高要求非标定制

SGB□□R/L

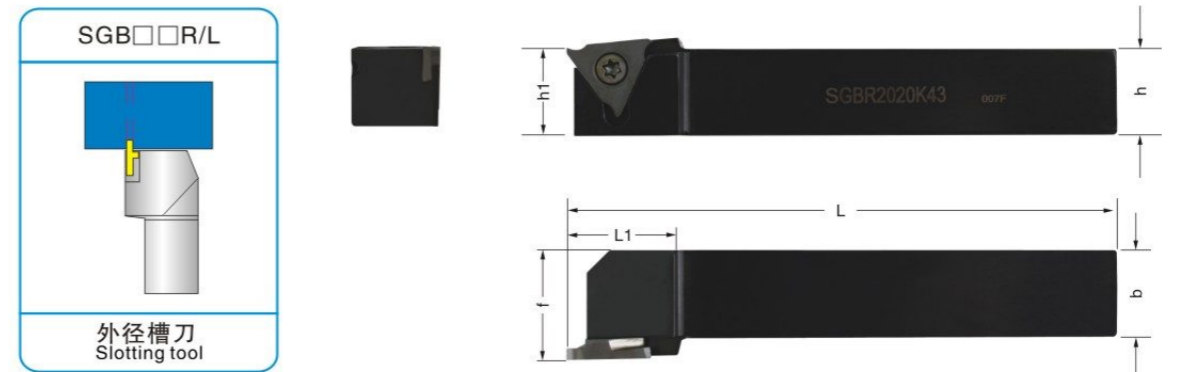

型号 Type	刀片 Blade	规格 Specification							螺丝 Screw	扳手 Wrench
		w	b	h	L	L1	h1	f		
SGBR/L1616H16	GBR/L32	0.33-2.5	16	16	100	22	16	20	M4 x 10	T15
SGBR/L2020K16		0.33-2.5	20	20	125	26	20	25		
SGBR/L2525M16		0.33-2.5	25	25	150	26	25	32		
SGBR/L1616H22-1	GBR/L43125-185	1.25-1.85	16	16	100	26	16	20	M5 x 12	T20
SGBR/L1616H22-2	GBR/L43200-280	2.0-2.8	16	16	100	26	16	20		
SGBR/L1616H22-3	GBR/L43300-450	3.0-4.5	16	16	100	26	16	20	M5 x 12	T20
SGBR/L2020K22-1	GBR/L43125-185	1.25-1.85	20	20	125	26	20	25		
SGBR/L2020K22-2	GBR/L43200-280	2.0-2.8	20	20	125	26	20	25		
SGBR/L2020K22-3	GBR/L43300-450	3.0-4.5	20	20	125	26	20	25		
SGBR/L2525M22-1	GBR/L43125-185	1.25-1.85	25	25	150	26	25	32		
SGBR/L2525M22-2	GBR/L43200-280	2.0-2.8	25	25	150	26	25	32		
SGBR/L2525M22-3	GBR/L43300-450	3.0-4.5	25	25	150	26	25	32		

▲更多型号可咨询, 可接受高要求非标定制

■ CGB□□R/L 专利产品 专利号: 2L2013 2 0320 273.5

外径槽刀
Slotting tool

型号 Type	刀片 Blade	规格 Specification							C型压板 Clamp	螺丝 Screw	双头螺丝 Screw	扳手 Wrench
		w	b	h	L	L1	h1	f				
CGBR/L1616H16	GB32R/L	0.5-2.5	16	16	100	22	16	20	HL1808	M4 x 10		T15 L2.5
CGBR/L2020K16		0.5-2.5	20	20	125	26	20	25				
CGBR/L2525M16		0.5-2.5	25	25	150	26	25	32				
CGBR/L1616H22-1	GB43R/L125-185	1.25-1.85	16	16	100	26	16	20		M5 x 12	ML0520	T20 L2.5
CGBR/L1616H22-2	GB43R/L200-280	2.0-2.8	16	16	100	26	16	20				
CGBR/L1616H22-3	GB43R/L300-450	3.0-4.5	16	16	100	26	16	20				
CGBR/L2020K22-1	GB43R/L125-185	1.25-1.85	20	20	125	26	20	25				
CGBR/L2020K22-2	GB43R/L200-280	2.0-2.8	20	20	125	26	20	25				
CGBR/L2020K22-3	GB43R/L300-450	3.0-4.5	20	20	125	26	20	25				
CGBR/L2525M22-1	GB43R/L125-185	1.25-1.85	25	25	150	26	25	32				
CGBR/L2525M22-2	GB43R/L200-280	2.0-2.8	25	25	150	26	25	32				
CGBR/L2525M22-3	GB43R/L300-450	3.0-4.5	25	25	150	26	25	32				

▲更多型号可咨询, 可接受高要求非标定制

■ KTGFR/L

外径槽刀
Slotting tool

型号 Type	刀片 Blade	规格 Specification							螺丝 Screw	扳手 Wrench
		w	b	h	L	h1	f	L1		
KTGFR/L1616H-16F	TGF32R/L	0.75-3.0	16	16	100	16	16	22	M4 x 10	T15
KTGFR/L2020K-16F			20	20	125	20	20	26		
KTGFR/L2525M-16F			25	25	150	25	25	26		
KTGFR/L1616H-16			16	16	100	16	20	22		
KTGFR/L2020K-16			20	20	125	20	25	26		
KTGFR/L2525M-16	25	25	150	25	32	26				
KTGFR/L1616H-22	TG43R/L	1.25-4.5	16	16	100	16	20	27	M5 x 12	T20
KTGFR/L2020K-22			20	20	125	20	25	27		
KTGFR/L2525M-22			25	25	150	25	32	27		

▲更多型号可咨询, 可接受高要求非标定制

■ CTGFR/L 专利产品 专利号: 2L2013 2 0320 275.4

外径槽刀
Slotting tool

型号 Type	刀片 Blade	规格 Specification							C型压板 Clamp	螺丝 Screw	双头螺丝 Screw	扳手 Wrench
		w	b	h	L	h1	f	L1				
CTGFR/L1616H-16F	TGF32R/L	0.75-3.0	16	16	100	16	16	22	HL1808	M4 x 10	ML0520	T15 L2.5
CTGFR/L2020K-16F			20	20	125	20	20	26				
CTGFR/L2525M-16F			25	25	150	25	25	26				
CTGFR/L1616H-16			16	16	100	16	20	22				
CTGFR/L2020K-16			20	20	125	20	25	26				
CTGFR/L2525M-16	25	25	150	25	32	26						
CTGFR/L1616H-22	TG43R/L	1.25-4.5	16	16	100	16	20	27		M5 x 12		T20 L2.5
CTGFR/L2020K-22			20	20	125	20	25	27				
CTGFR/L2525M-22			25	25	150	25	32	27				

▲更多型号可咨询, 可接受高要求非标定制

■ PCHR/L

外径槽刀
Slotting tool

型号 Type	刀片 Blade	规格 Specification					螺丝 Screw	扳手 Wrench
		b	h	L	L1	f		
PCHR/L16-24	PENTA24N239J015	16	16	100	26	16.6	M4.5 x 10	T20
PCHR/L20-24		20	20	125	26	20.6		
PCHR/L25-24		25	25	150	26	25.5		

▲更多型号可咨询, 可接受高要求非标定制

SVQBR/L

正手刀 反手刀
正手和反手刀片通装

外径槽刀
Slotting tool

型号 Type	刀片 Blade	规格 Specification					螺丝 Screw	扳手 Wrench
		b	h	L	f	h1		
SVQBR/L2020K16-NJ	FB1604口口	20	20	125	20	24	M4 x 10	T15
SVQBR/L2525M16-NJ		25	25	150	25	29		
SVQCR/L2020K16-NJ	FC1604口口	20	20	125	20	24		
SVQCR/L2525M16-NJ		25	25	150	25	29		

▲更多型号可咨询, 可接受高要求非标定制

SGEL

外径槽刀
Slotting tool

型号 Type	刀片 Blade	规格 Specification								螺丝 Screw	扳手 Wrench
		h	b	L	H	F	Tmax	最小加工直径			
SGEL1616H-D	GER口口-D	16	16	100	16	16	5	10	M3X8	T8	
SGEL2020K-D		20	20	125	20	20	5	10			
SGEL2525M-D		25	25	150	25	25	5	10			
SGEL1616H-D-F		16	16	100	16	16	5	10			
SGEL2020K-D-F		20	20	125	20	20	5	10			
SGEL2525M-D-F		25	25	150	25	25	5	10			

▲更多型号可咨询, 可接受高要求非标定制

SGESR

外径槽刀
Slotting tool

型号 Type	刀片 Blade	规格 Specification					螺丝 Screw	扳手 Wrench	
		h	b	L	H	F			Tmax
SGESR1616H-D	GER口口-D	16	16	100	16	16	5	M3X8	T8
SGESR2020K-D		20	20	125	20	20	5		
SGESR2525M-D		25	25	150	25	25	5		

▲更多型号可咨询, 可接受高要求非标定制

□□□SR/L

外径槽刀
Slotting tool

型号 Type	刀片 Blade	规格 Specification							螺丝 Screw	扳手 Wrench
		w	b	h	L	h1	f	L1		
KTGFSR/L1010H-16	TGF32R/L	0.75-3.0	10	10	100	10	14	15	M4 x 10	T15
KTGFSR/L1212H-16			12	12	100	12	16	16		
KTGFSR/L1616H-16			16	16	100	16	20	22		
KTGFSR/L2020K-16			20	20	125	20	25	26		
KTGFSR/L2525M-16			25	25	150	25	32	26		
SGBSR/L1616H-16	GBA32R/L	0.33-3.0	16	16	100	16	20	22	M4 x 10	T15
SGBSR/L2020K-16			20	20	125	20	25	26		
SGBSR/L2525M-16			25	25	150	25	32	26		

▲更多型号可咨询, 可接受高要求非标定制

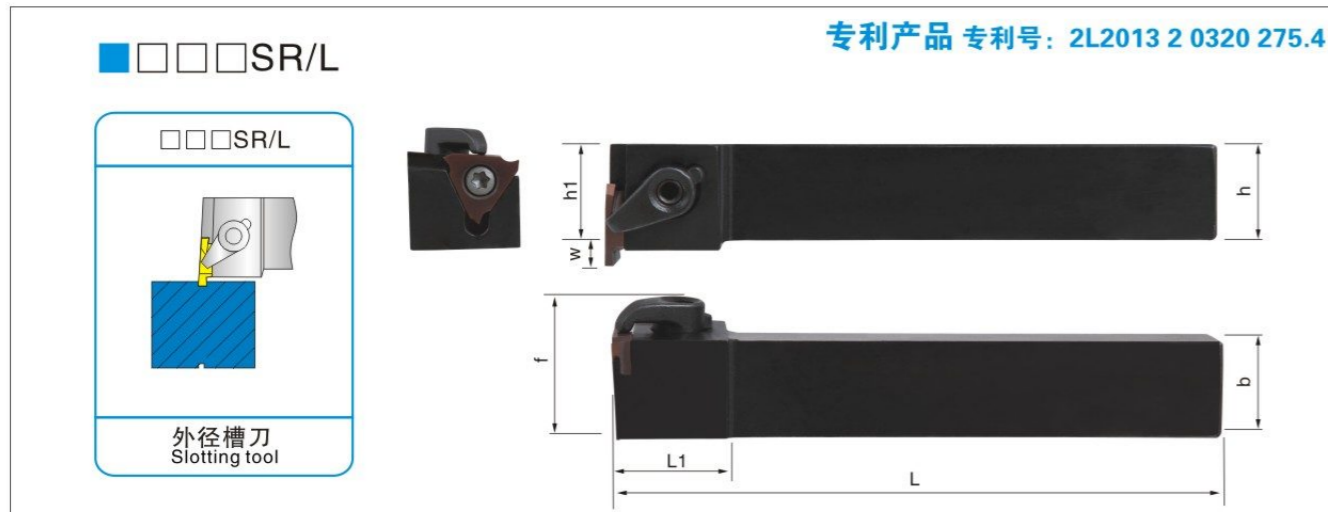

型号 Type	刀片 Blade	规格 Specification							C型压板 Clamp	螺丝 Screw	双头螺丝 Screw	扳手 Wrench
		w	b	h	L	h1	f	L1				
CTGFSR/L1616H-16	TGF32R/L	0.75-3.0	16	16	100	16	16	22	HL1808	M4 x 10	ML0520	T15 L2.5
CTGFSR/L2020K-16			20	20	125	20	20	26				
CTGFSR/L2525M-16			25	25	150	25	25	26				
CGBSR/L1616H-16	GBA32R/L	0.33-3.0	16	16	100	16	20	22				
CGBSR/L2020K-16			20	20	125	20	25	26				
CGBSR/L2525M-16			25	25	150	25	32	26				

▲更多型号可咨询, 可接受高要求非标定制

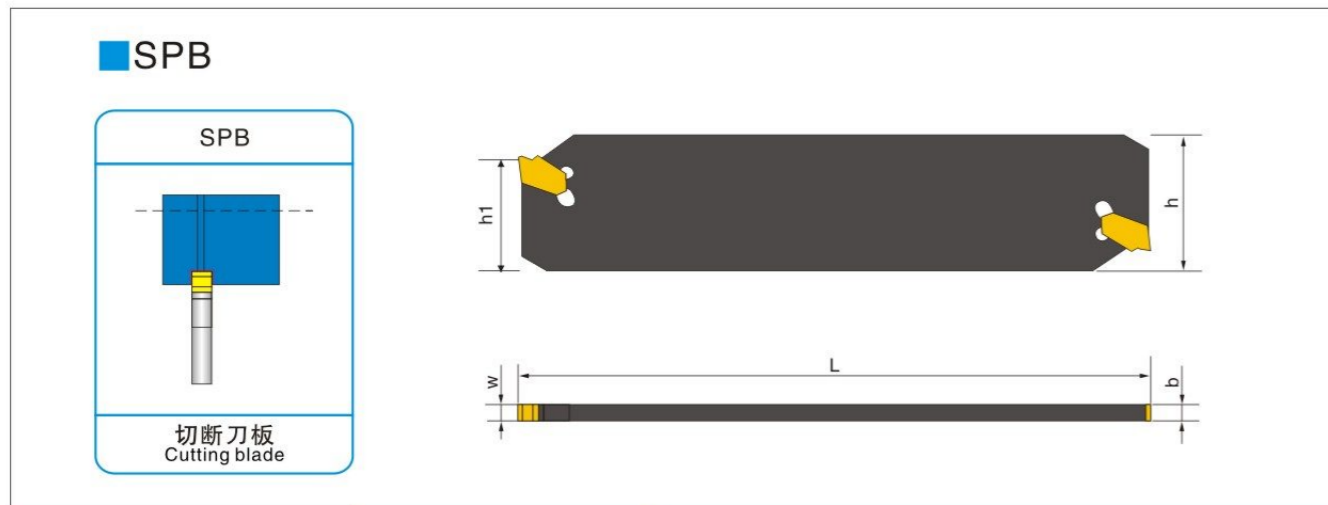

型号 Type	刀片 Blade	规格 Specification				
		w	b	h	L	h1
SPB226	SP200,200R/L	2	1.6	26	26	21
SPB326	ZQM x 3N-11-1E SP300,300R/L	3	2.4	26	26	21
SPB426	ZQM x 4N-11-1E SP400,400R/L	4	3.2	26	26	21
SPB526	ZQM x 5N-11-1E SP500,500R/L	5	4.2	26	26	21
SPB232	SP200,200R/L	2	1.6	32	32	25
SPB332	ZQM x 3N-11-1E SP300,300R/L	3	2.4	32	32	25
SPB432	ZQM x 4N-11-1E SP400,400R/L	4	3.2	32	32	25
SPB532	ZQM x 5N-11-1E SP500,500R/L	5	4.2	32	32	25
SPB632	ZQM x 6N-11-1E SP600,600R/L	6	5.2	32	32	25

▲更多型号可咨询, 可接受高要求非标定制

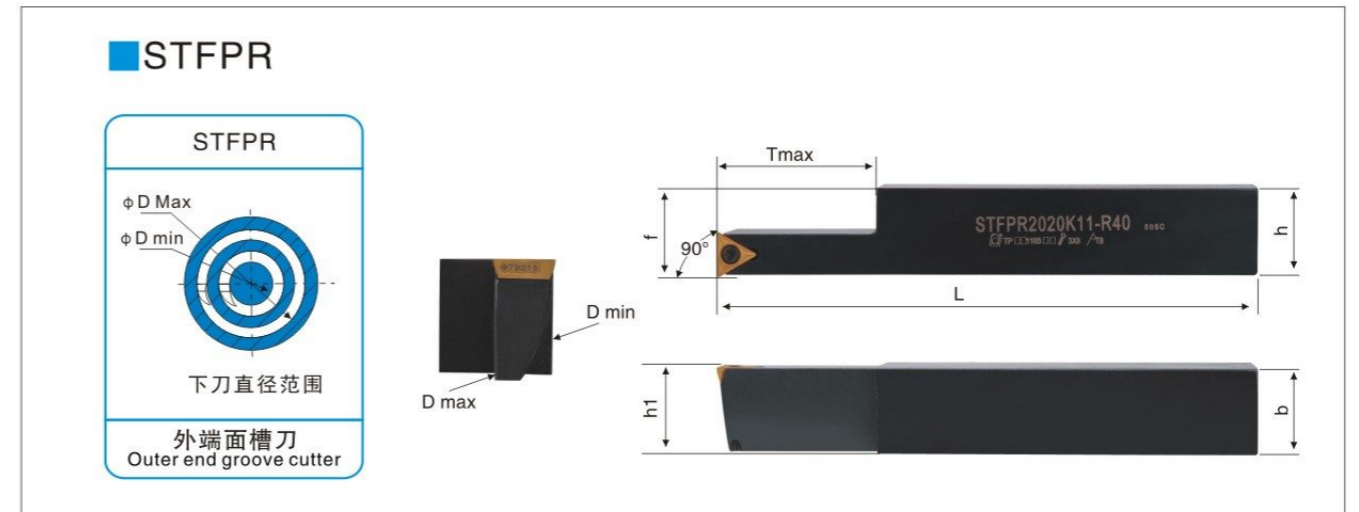

型号 Type	刀片 Blade	规格 Specification							螺丝 Screw	扳手 Wrench
		f	b=h1	h	L	Min	Max	Tmax		
STFPR2020K09-R40	TP□□0902□□	20.5	20	20	125	80	500	32	M2.5 x 6	T8
STFPR2020K11-R40	TP□□1103□□	20.7	20	20	125	80	500	37	M3 x 8	

▲更多型号可咨询, 可接受高要求非标定制

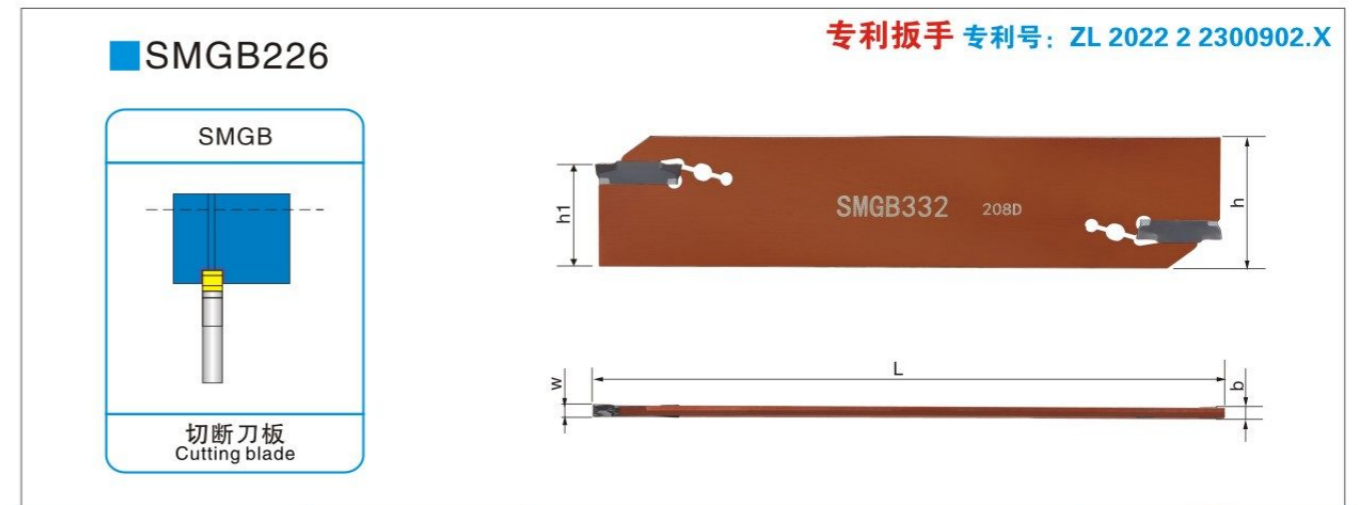

型号 Type	刀片 Blade	规格 Specification					扳手 Wrench
		w	b	h	L	h1	
SMGB226	MGMN200	2	2.4	26	110	21	DB-L5
SMGB232				32	150	25	
SMGB326	MGMN300	3	1.6	26	110	21	
SMGB332				32	150	25	
SMGB426	MGMN400	4	3.3	26	110	21	
SMGB432				32	150	25	

▲更多型号可咨询, 可接受高要求非标定制

专利扳手 专利号: ZL 2022 2 2300902.X

SSACN

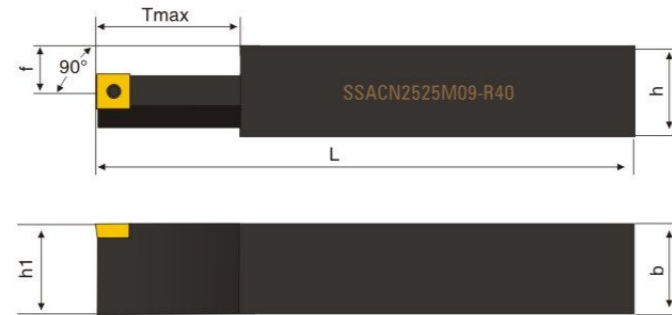
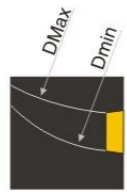
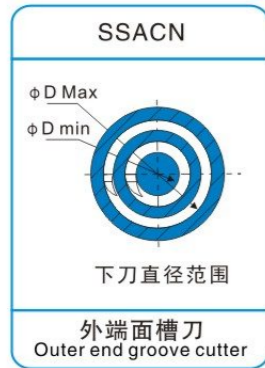

型号 Type	刀片 Blade	规格 Specification							螺丝 Screw	扳手 Wrench
		f	b=h1	h	L	Min	Max	Tmax		
SSACN2020K09-R35	SC□□09T3□□	10	20	20	125	80	500	35	M4 x 10	T15
SSACN2525M09-R40		12.5	25	25	150	80	500	40		

▲更多型号可咨询, 可接受高要求非标定制

STACR/L

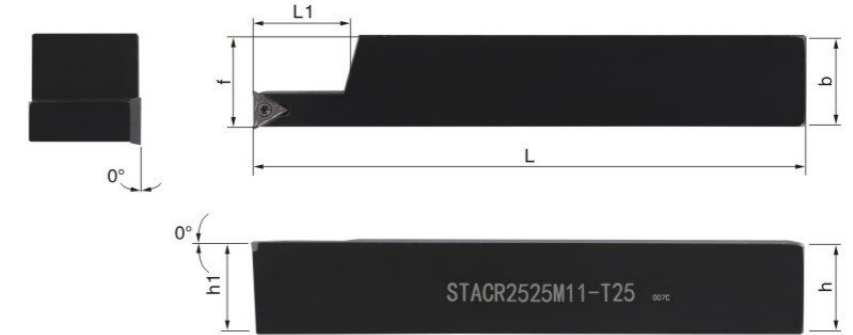
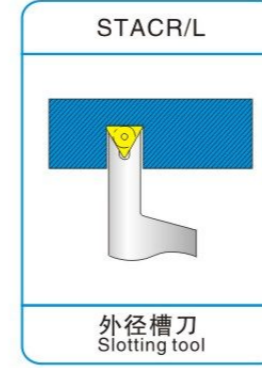

型号 Type	刀片 Blade	规格 Specification						螺丝 Screw	扳手 Wrench
		h	b	L	L1	h1	f		
STACR2020K06	TBGT060102	20	20	125	20	20	20.3	M2.2X6	T6
STACR2525M06		25	25	150	20	25	25.3		
STACR2020K09		20	20	125	23	20	20.3		
STACR2525M09	TC□0902□	25	25	150	23	25	25.3	M2.5X7	T6
STACR2020K11	TC□1102□	20	20	125	25	20	20.3		
STACR2525M11		25	25	150	25	25	25.3		

▲更多型号可咨询, 可接受高要求非标定制

STC

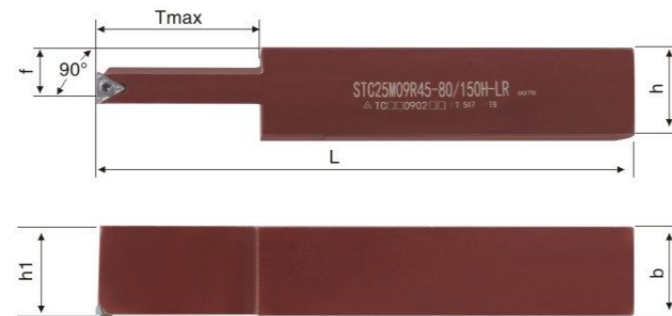

型号 Type	刀片 Blade	规格 Specification							螺丝 Screw	扳手 Wrench
		f	b=h1	h	L	Min	Max	Tmax		
STC20K09R40-80/150-LR	TC□□0902□□	10	20	20	125	80	80	40	M2.5X7	T8
STC20K11R40-80/150-LR		TC□□1102□□	10	20	20	125	80	80		
STC25M09R40-80/150-LR	TC□□0902□□	12.5	25	25	150	80	80	45	M2.5X7	T8
STC25M11R40-80/150-LR	TC□□1102□□	12.5	25	25	150	80	80	45		

▲更多型号可咨询, 可接受高要求非标定制

SRAPR/L



型号 Type	刀片 Blade	规格 Specification							螺丝 Screw	扳手 Wrench
		f	h	b	L	Min	Max	Tmax		
SRAPR/L2020K10T3-30/200-T20	RP10T3	15.8	20	20	125	30	200	20	M3.5X10	T15
SRAPR/L2020K10T3-50/200-T40		15.8	20	20	125	50	200	40		
SRAPR/L2525M10T3-30/200-T20		20.8	25	25	150	30	200	20		
SRAPR/L2525M10T3-50/200-T40	RP1204	20.8	25	25	150	50	200	40	M4X10	T15
SRAPR/L2020K1204-30/200-T20		15	20	20	125	30	200	20		
SRAPR/L2020K1204-50/200-T40		15	20	20	125	50	200	40		
SRAPR/L2525M1204-30/200-T20		20	25	25	150	30	200	20		
SRAPR/L2525M1204-50/200-T40	20	25	25	150	50	200	40			

▲更多型号可咨询, 可接受高要求非标定制

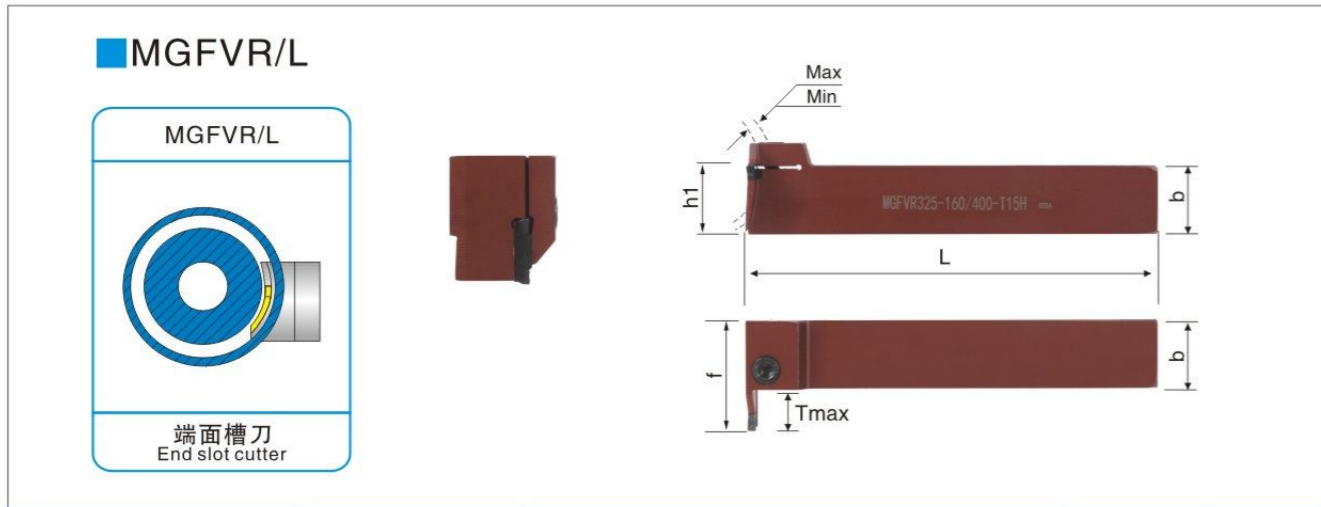

型号 Type	刀片 Blade	规格 Specification							螺丝 Screw	扳手 Wrench			
		f	b=h1	h	L	Min	Max	Tmax					
MGFVR320-24/36-T13H	MGMN300-□	33	20	20	125	24	36	13	M6 × 20	L5			
MGFVR325-24/36-T13H		38	25	25	150	24	36	13					
MGFVR320-30/50-T15H		35	20	20	125	30	50	15					
MGFVR325-30/50-T15H		40	25	25	150	30	50	15					
MGFVR320-55/80-T15H		35	20	20	125	55	80	15					
MGFVR325-55/80-T15H		40	25	25	150	55	80	15					
MGFVR320-80/160-T15H		35	20	20	125	80	160	15					
MGFVR325-80/160-T15H		40	25	25	150	80	160	15					
MGFVR320-160/400-T15H		35	20	20	125	160	400	15					
MGFVR325-160/400-T15H		40	25	25	150	160	400	15					
MGFVR420-24/36-T13H		MGMN400-□	33	20	20	125	24	36			13	M6 × 20	L5
MGFVR425-24/36-T13H			38	25	25	150	24	36			13		
MGFVR420-30/50-T15H	35		20	20	125	30	50	15					
MGFVR425-30/50-T15H	40		25	25	150	30	50	15					
MGFVR420-55/80-T15H	35		20	20	125	55	80	15					
MGFVR425-55/80-T15H	40		25	25	150	55	80	15					
MGFVR420-80/160-T15H	35		20	20	125	80	160	15					
MGFVR425-80/160-T15H	40		25	25	150	80	160	15					
MGFVR420-160/400-T15H	35		20	20	125	160	400	15					
MGFVR425-160/400-T15H	40		25	25	150	160	400	15					

▲更多型号可咨询, 可接受高要求非标定制

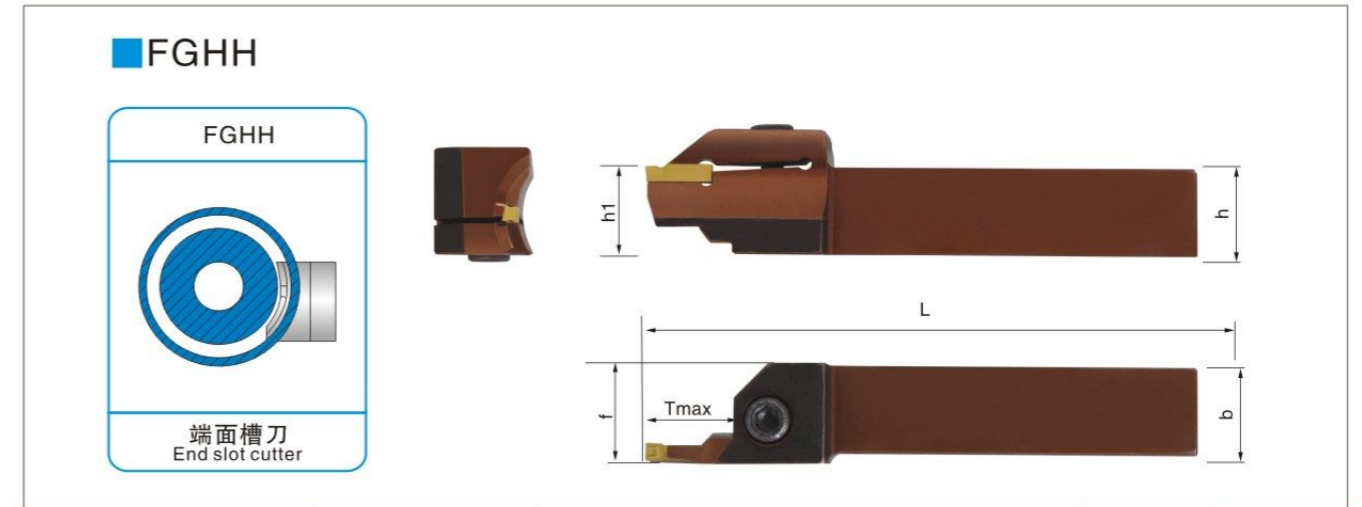

型号 Type	刀片 Blade	规格 Specification							螺丝 Screw	扳手 Wrench
		f	b=h1	h	L	Min	Max	Tmax		
FGHH320-25/35	FGD300R-03	20.6	20	20	125	25	35	10	M6 × 20	L5
FGHH320-35/48		20.6	20	20	125	35	48	12		
FGHH320-48/66		20.6	20	20	125	48	66	13		
FGHH320-64/100		20.6	20	20	125	64	100	15		
FGHH320-98/160		20.6	20	20	125	98	160	17		
FGHH320-160/300		20.6	20	20	125	160	300	20		
FGHH420-25/35		FGD400R-04	20.6	20	20	125	25	35		
FGHH420-35/48	20.6		20	20	125	35	48	12		
FGHH420-48/66	20.6		20	20	125	48	66	13		
FGHH420-64/100	20.6		20	20	125	64	100	15		
FGHH420-98/160	FGD500R-04	20.6	20	20	125	98	160	20	M6 × 20	L5
FGHH420-160/300		20.6	20	20	125	160	300	20		
FGHH520-25/35		20.6	20	20	125	25	35	12		
FGHH520-35/48		20.6	20	20	125	35	48	15		
FGHH520-48/66		20.6	20	20	125	48	66	17		
FGHH520-64/100		20.6	20	20	125	64	100	20		
FGHH520-98/160		20.6	20	20	125	98	160	20		
FGHH520-160/300	20.6	20	20	125	160	300	25			

▲更多型号可咨询, 可接受高要求非标定制

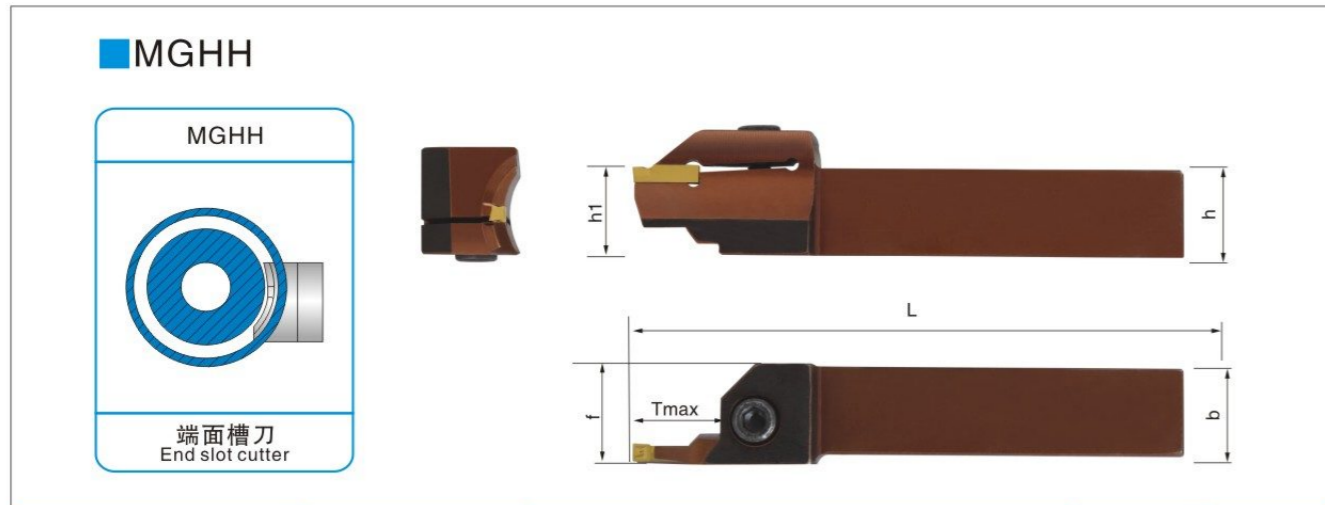

型号 Type	刀片 Blade	规格 Specification							螺丝 Screw	扳手 Wrench		
		f	b=h1	h	L	Min	Max	Tmax				
MGHH216R06-20/30	MGMN200-□	16.6	16	16	100	20	30	6	M5X18	L4		
MGHH216R08-30/50		16.6	16	16	100	30	50	8				
MGHH216R08-50/80		16.6	16	16	100	50	80	8				
MGHH220R06-20/30		20.6	20	20	125	20	30	6				
MGHH220R08-30/50		20.6	20	20	125	30	50	8				
MGHH220R08-50/80		20.6	20	20	125	50	80	8				
MGHH225R08-50/80		25.6	25	25	150	50	80	8				
MGHH225R08-80/120		25.6	25	25	150	80	120	8				
MGHH320R-24/36		20.6	20	20	125	24	36	13			M6X20	L5
MGHH325R-24/36		25.6	25	25	150	24	36	13				
MGHH320R-35/48	20.6	20	20	125	35	48	13					
MGHH325R-35/48	25.6	25	25	150	35	48	13					
MGHH325R-36/48-T25	26	25	25	150	36	48	25					
MGHH325R-48/60-T25	26	25	25	150	48	60	25					
MGHH320R-48/66	20.6	20	20	125	48	66	17					
MGHH325R-48/66	25.6	25	25	150	48	66	17					
MGHH320R-55/80	20.6	20	20	125	55	80	17					
MGHH325R-55/80	25.6	25	25	150	55	80	17					
MGHH325R-55/80-T25	26	25	25	150	55	80	25					
MGHH320R-64/100	20.6	20	20	125	64	100	17					
MGHH325R-64/100	25.6	25	25	150	64	100	17					
MGHH325R-64/100-T25	26	25	25	150	64	100	25					
MGHH320R-80/120	20.6	20	20	125	80	120	17					
MGHH325R-80/120	25.6	25	25	150	80	120	17					
MGHH325R-80/120-T25	26	25	25	150	80	120	25					
MGHH320R-98/160	20.6	20	20	125	98	160	17					
MGHH325R-98/160	25.6	25	25	150	98	160	17					
MGHH325R-98/160-T25	26	25	25	150	98	160	25					
MGHH325R-100/200-T25	26	25	25	150	100	200	25					
MGHH320R-120/200	20.6	20	20	125	120	200	17					
MGHH325R-120/200	25.6	25	25	150	120	200	17					
MGHH320R-160/400	20.6	20	20	125	160	400	17					
MGHH325R-160/400	25.6	25	25	150	160	400	17					
MGHH325R-160/400-T25	26	25	25	150	160	400	25					
MGHH325R-200/800	25.6	25	25	150	200	800	17					
MGHH325R-200/800-T25	26	25	25	150	200	800	25					

▲更多型号可咨询, 可接受高要求非标定制

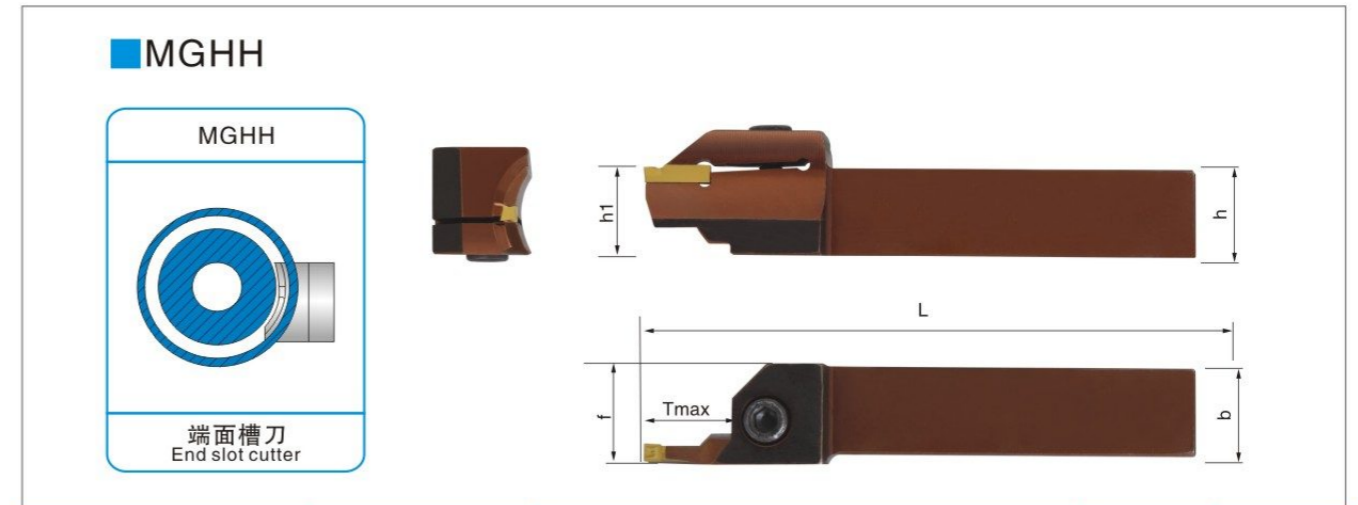

型号 Type	刀片 Blade	规格 Specification							螺丝 Screw	扳手 Wrench	
		f	b=h1	h	L	Min	Max	Tmax			
MGHH420R-24/36	MGMN400-□	20.6	20	20	125	24	36	13	M6X20	L5	
MGHH425R-24/36		25.6	25	25	150	24	36	13			
MGHH420R-35/48		20.6	20	20	125	35	48	13			
MGHH425R-35/48		25.6	25	25	150	35	48	13			
MGHH425R-36/48-T25		26	25	25	150	36	48	25			
MGHH425R-48/60-T25		26	25	25	150	48	60	25			
MGHH420R-48/66		20.6	20	20	125	48	66	17			
MGHH425R-48/66		25.6	25	25	150	48	66	17			
MGHH420R-55/80		20.6	20	20	125	55	80	17			
MGHH425R-55/80		25.6	25	25	150	55	80	17			
MGHH425R-55/80-T25		26	25	25	150	55	80	25			
MGHH420R-64/100		20.6	20	20	125	64	100	17			
MGHH425R-64/100		25.6	25	25	150	64	100	17			
MGHH425R-64/100-T25		26	25	25	150	64	100	25			
MGHH420R-80/120		20.6	20	20	125	80	120	17			
MGHH425R-80/120		25.6	25	25	150	80	120	17			
MGHH425R-80/120-T25		26	25	25	150	80	120	25			
MGHH420R-98/160		20.6	20	20	125	98	160	17			
MGHH425R-98/160		25.6	25	25	150	98	160	17			
MGHH425R-98/160-T25		26	25	25	150	98	160	25			
MGHH425R-100/200-T25		26	25	25	150	100	200	25			
MGHH420R-120/200		20.6	20	20	125	120	200	17			
MGHH425R-120/200		25.6	25	25	150	120	200	17			
MGHH420R-160/400		20.6	20	20	125	160	400	17			
MGHH425R-160/400		25.6	25	25	150	160	400	17			
MGHH425R-160/400-T25		26	25	25	150	160	400	25			
MGHH425R-200/800		25.6	25	25	150	200	800	17			
MGHH425R-200/800-T25		26	25	25	150	200	800	25			
MGHH525R20-50-80H		MGMN500-□	25.6	25	25	150	50	80			20
MGHH525R20-80-160H			25.6	25	25	150	80	160			20
MGHH525R20-160-400H			25.6	25	25	150	160	400			20

▲更多型号可咨询, 可接受高要求非标定制

QFFD/QFGD

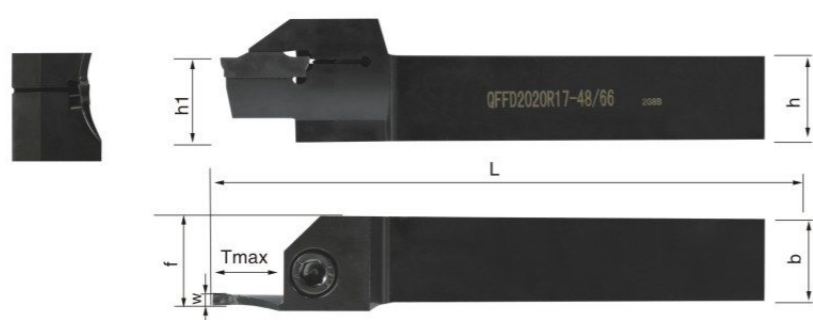

QFHD/QFHS/QFKD/QFKS



型号 Type	刀片 Blade	规格 Specification						螺丝 Screw	扳手 Wrench	
		h × b	L	f	w	Tmax	φ D min-max			
QFFD	ZTFD0303-MG	2020R/L7-48H	20 × 20	150	21	3	7	48-66	GB70-85-M6 × 20	WH50L
		2020R/L10-48H	20 × 20	150	21	3	10	48-66		
		2525R/L10-48H	25 × 25	150	26	3	10	48-66		
		2525R/L17-48H	25 × 25	150	26	3	17	48-66		
		2020R/L7-60H	20 × 20	150	21	3	7	60-80		
		2020R/L10-60H	20 × 20	150	21	3	10	60-80		
		2525R/L10-60H	25 × 25	150	26	3	10	60-80		
		2525R/L17-60H	25 × 25	150	26	3	17	60-80		
		2020R/L7-74H	20 × 20	150	21	3	7	74-100		
		2020R/L10-74H	20 × 20	150	21	3	10	74-100		
		2525R/L10-74H	25 × 25	150	26	3	10	74-100		
		2525R/L17-74H	25 × 25	150	26	3	17	74-100		
		2020R/L7-100H	20 × 20	150	21	3	7	100-150		
		2020R/L10-100H	20 × 20	150	21	3	10	100-150		
		2525R/L10-100H	25 × 25	150	26	3	10	100-150		
		2525R/L17-100H	25 × 25	150	26	3	17	100-150		
QFGD	ZTGD0404-MG	2020R/L10-52H	20 × 20	150	21	4	10	52-72	GB70-85-M6 × 20	WH50L
		2525R/L13-52H	25 × 25	150	26	4	13	52-72		
		2020R/L15-52H	20 × 20	150	21	4	15	52-72		
		2525R/L22-52H	25 × 25	150	26	4	22	52-72		
		2020R/L10-64H	20 × 20	150	21	4	10	64-100		
		2525R/L13-64H	25 × 25	150	26	4	13	64-100		
		2020R/L15-64H	20 × 20	150	21	4	15	64-100		
		2525R/L22-64H	25 × 25	150	26	4	22	64-100		
		2020R/L10-90H	20 × 20	150	21	4	10	90-140		
		2525R/L13-90H	25 × 25	150	26	4	13	90-140		
		2020R/L15-90H	20 × 20	150	21	4	15	90-140		
		2525R/L22-90H	25 × 25	150	26	4	22	90-140		
		2020R/L10-130H	20 × 20	150	21	4	10	130-230		
		2525R/L13-130H	25 × 25	150	26	4	13	130-230		
		2020R/L15-130H	20 × 20	150	21	4	15	130-230		
		2525R/L22-130H	25 × 25	150	26	4	22	130-230		

▲更多型号可咨询, 可接受高要求非标定制

型号 Type	刀片 Blade	规格 Specification						螺丝 Screw	扳手 Wrench			
		h × b	L	f	w	Tmax	φ D min-max					
QFHD	ZTHD0504-MG	2525R/L13-58H	25 × 25	150	26	5	13	58-96	GB70-85-M6 × 20	WH50L		
		2525R/L22-58H	25 × 25	150	26	5	22	58-96				
		2525R/L13-86H	25 × 25	150	26	5	13	86-140				
		2525R/L22-86H	25 × 25	150	26	5	22	86-140				
		2525R/L13-130H	25 × 25	150	26	5	13	130-200				
		2525R/L22-130H	25 × 25	150	26	5	22	130-200				
		2525R/L13-185H	25 × 25	150	26	5	13	185-400				
		2525R/L22-185H	25 × 25	150	26	5	22	185-400				
QFHS	2525R/L30-185H	ZTHS0504-MG	25 × 25	150	26	5	30	185-400	GB70-85-M6 × 20	WH50L		
QFKD	ZTKD0608-MG	2525R/L13-60H	25 × 25	150	26	6	13	60-100				
		2525R/L22-60H	25 × 25	150	26	6	22	60-100				
		2525R/L13-88H	25 × 25	150	26	6	13	88-180				
		2525R/L22-88H	25 × 25	150	26	6	22	88-180				
QFKS	ZTKS0608-MG	2525R/L13-160H	25 × 25	150	26	6	13	160-400			GB70-85-M6 × 20	WH50L
		2525R/L22-160H	25 × 25	150	26	6	22	160-400				
QFKS	2525R/L30-160H	ZTKS0608-MG	25 × 25	150	26	6	30	160-400				

▲更多型号可咨询, 可接受高要求非标定制

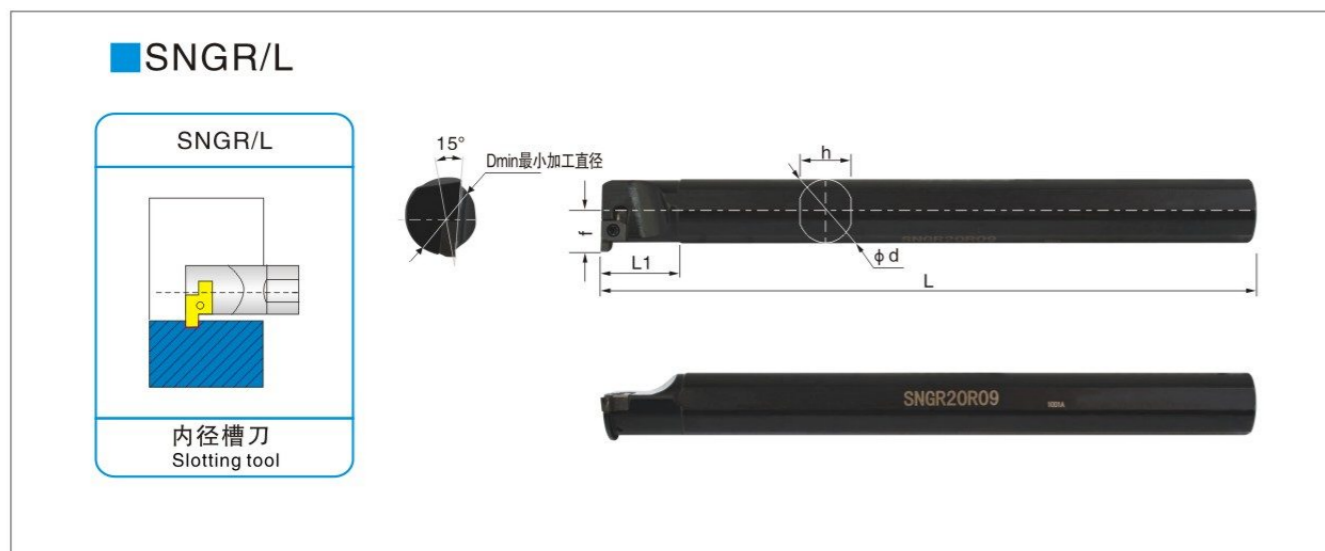

型号 Type	刀片 Blade	规格 Specification							螺丝 Screw	扳手 Wrench
		Dmin	Tmax	φ d	F	L1	L	H		
SNGR/L0806J06	6GR/L	8.5	2	8	4.7	15	110	7	M2.2×4	T7
SNGR/L08J07	7GR/L	10.5	2	8	5.8	15	110	7	M2.5×6	T7
SNGR/L10K07	7GR/L	12.5	2	10	6.8	15	125	8	M2.5×6	T7
SNGR/L10K08	8GR/L	13	3.5	10	7.6	20	125	8	M2.5×6	T7
SNGR/L12M08	8GR/L	15	3.5	12	8.6	20	150	11	M2.5×6	T7
SNGR/L16Q09	9GR/L	20	3.5	16	11.6	20	180	14.8	M2.5×6	T8
SNGR/L20R09	9GR/L	24	3.5	20	13.6	20	200	18.4	M2.5×6	T8

▲更多型号可咨询，可接受高要求非标定制

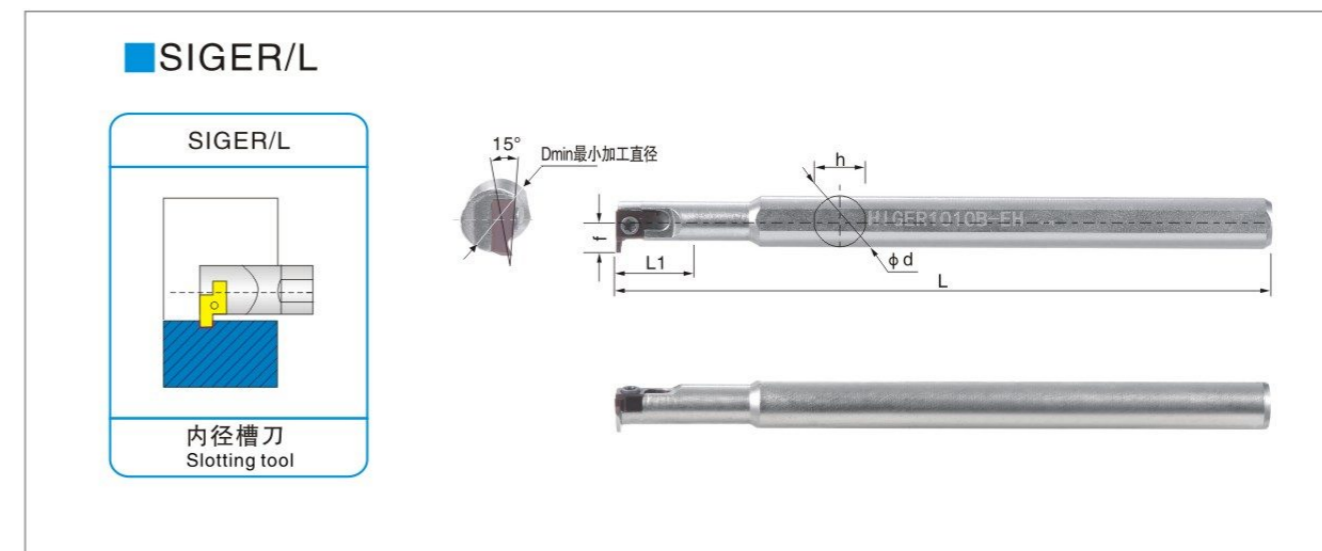

型号 Type	刀片 Blade	规格 Specification							螺丝 Screw	扳手 Wrench
		Tmax (切深)	Φ d	Dmin	L1	L	H	F		
SIGER0606A-EH	GER□□A	1.5	6	8	20	100	5.4	4.8	M2.2X6	T6
SIGER0808A-EH			8	8	20	125	7	4.8		
SIGER1010B-EH	GER□□B	2.2	10	10	25	125	9	6.2	M2.5X6	T8
SIGER1210B-EH			10	12	30	125	9	7		
SIGER1212B-EH			12	12	30	150	11	7		
SIGER1412C-EH	GER□□C	2.5	12	14	33	150	11	8.3	M2.5X7	T8
SIGER1612C-EH			12	16	33	150	11	8.5		
SIGER1616C-EH			16	16	36	160	14.8	9		
SIGER2020D-EH	GER□□D	4.5	20	20	45	180	18.4	12.1	M3X8	T8
SIGER2525D-EH			25	25	45	200	23.2	12.3		
SIGER2520E-EH	GER□□E	6.5	20	25	50	180	18.4	15.8	M4X10	T15
SIGER2525E-EH			25	25	50	200	23.2	15.8		
SIGER3232E-EH			32	25	55	220	31	19		

▲更多型号可咨询，可接受高要求非标定制

MGIVR/L

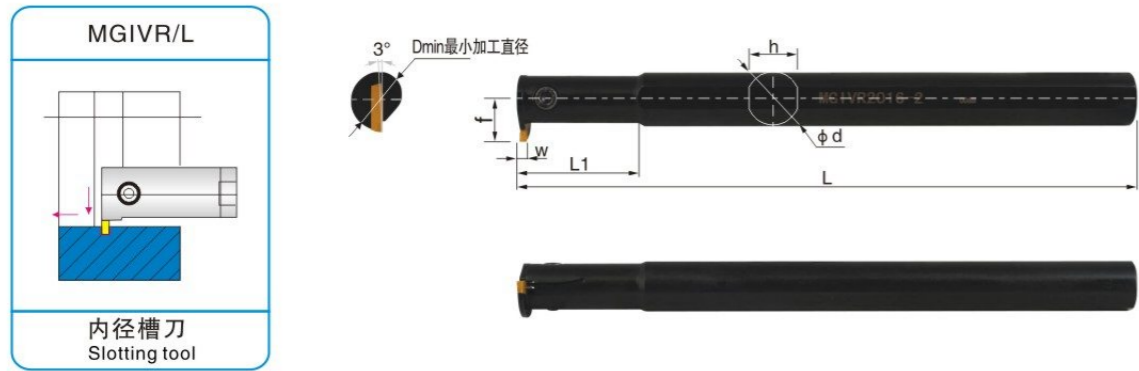

TTIR



型号 Type	刀片 Blade	规格 Specification							螺丝 Screw	扳手 Wrench
		Dmin	w	φ d	f	L	L1	h		
MGIVR/L2016-1.5	MGMN150	21	1.5	16	12.4	160	38	14.8	M4 × 15	L3
MGIVR/L2416-1.5T8		24	1.5	16	16	160	30	14.8		
MGIVR/L2520-1.5		26	1.5	20	14	180	45	18.4		
MGIVR/L2820-1.5T8		28	1.5	20	17.5	180	35	18.4	M5 × 18	L4
MGIVR/L2925-1.5		30	1.5	25	17.25	200	50	23.4		
MGIVR/L3525-1.5T10		35	1.5	25	22.5	200	37	23.4		
MGIVR/L2016-2	MGMN200	21	2	16	12.4	160	38	14.8	M4 × 15	L3
MGIVR/L2520-2		26	2	20	14	180	45	18.4	M5 × 20	L4
MGIVR/L2616-2T10		26	2	16	18	160	30	14.8	M4 × 15	L3
MGIVR/L2925-2		30	2	25	17.25	200	50	23.4	M5 × 20	L4
MGIVR/L3020-2T10		30	2	20	19.5	180	35	18.4		
MGIVR/L3525-2T10		35	2	25	22.5	200	37	23.4		
MGIVR/L2016-2.5	MGMN250	22	2.5	16	13.25	180	38	18.4	M4 × 15	L3
MGIVR/L2520-2.5		27	2.5	20	16	200	45	14.8	M5 × 18	L4
MGIVR/L2925-2.5		30	2.5	25	17.5	250	50	23.4		
MGIVR/L2016-3	MGMN300 MRMN300	23	3	16	15	110	38	14.8	M4 × 15	L3
MGIVR/L2520-3		27	3	20	15.6	180	45	18.4	M5 × 20	L4
MGIVR/L2816-3T12		28	3	16	20	160	30	14.8	M4 × 15	L3
MGIVR/L3120-3T12		32	3	20	21.5	180	35	18.4	M5 × 18	L4
MGIVR/L3125-3		32	3	25	18.9	200	50	23.4	M5 × 20	L4
MGIVR/L3625-3T12		37	3	25	24	200	37	23.4	M6 × 16	L5
MGIVR/L3732-3		38	3	32	21.5	250	65	30	M6 × 20	L5
MGIVR/L4532-3T15		46	3	32	30	250	55	30	M6 × 20	L5
MGIVR/L4540-3		48	3	40	27.2	300	70	38	M8 × 30	L6
MGIVR/L2016-4		MGMN400 MRMN400	23	4	16	15	160	38	14.8	M4 × 15
MGIVR/L2520-4	27		4	20	15.6	180	45	18.4	M5 × 20	L4
MGIVR/L2816-4T12	28		4	16	20	160	30	14.8	M4 × 15	L3
MGIVR/L3120-4T12	32		4	20	21.5	180	35	18.4	M5 × 18	L4

▲更多型号可咨询, 可接受高要求非标定制

型号 Type	刀片 Blade	规格 Specification							螺丝 Screw	扳手 Wrench
		Dmin	w	φ d	f	L	L1	H		
TTIR/L16-2C	TDC2	24	2	16	16.5	125	40	14.8	M4 × 15	L3
TTIR/L20-2C		26	2	20	15.8	160	40	18.4		
TTIR/L25-2C		30	2	25	17.5	200	40	23.4		
TTIR/L20-3C	TDC3	26	3	20	15.8	160	40	18.4	M5 × 18	L4
TTIR/L25-3C		30	3	25	17.5	200	40	23.4		
TTIR/L32-3C		40	3	32	19.8	250	60	30		
TTIR/L20-4C	TDC4	26	4	20	15.8	160	40	18.4	M5 × 18	L4
TTIR/L25-4C		30	4	25	17.5	200	40	23.4		
TTIR/L32-4C		40	4	32	20.8	250	60	30		

▲更多型号可咨询, 可接受高要求非标定制

铝材仿形车削刀具

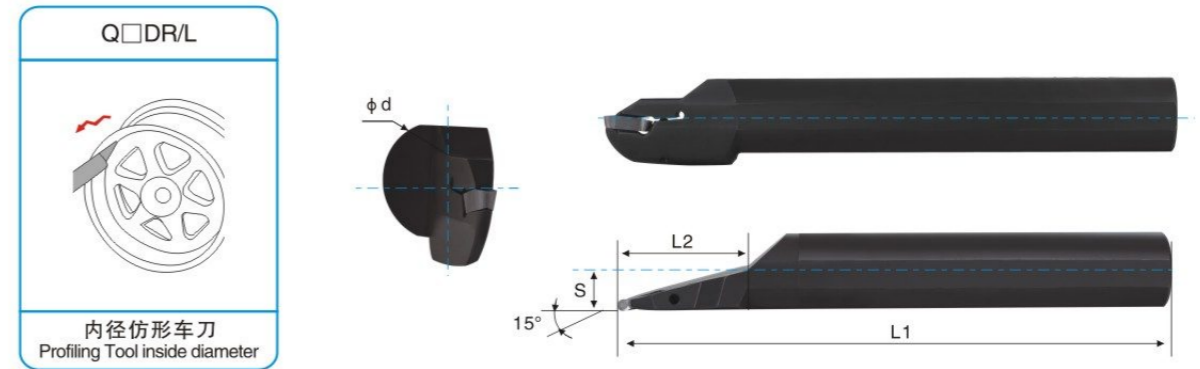

型号 Type	刀片 Blade	规格 Specification					螺丝 Screw	扳手 Wrench
		φ Dmin (最小加工直径)	φ d	S	L1	L2		
C40T-QLDR/L65-15A	ZRLD08-LH	160	40	21	300	65	M6 × 20	L5
C40T-QLDR/L80-15A		160	40	21	300	80		
C50U-QLDR/L80-15A		160	50	26	350	80		
C40T-QKDR/L60-15A	ZRKD06-LH	160	40	21	300	60	M6 × 20	L5
C40T-QKDR/L75-15A		160	40	21	300	75		
C50U-QKDR/L75-15A		160	50	26	350	75		

▲更多型号可咨询, 可接受高要求非标定制

KTGFR/L

KTGFR/L

外径槽刀
Slotting tool

型号 Type	刀片 Blade	规格 Specification						螺丝 Screw	扳手 Wrench
		ϕ Dmin	ϕ d	f	L	L1	H		
S16N-KTGFR/L16	TGF32R/L	20	16	11	160	30	15	M4 x 10	T15
S20Q-KTGFR/L16		24	20	12.8	180	40	19		
S25R-KTGFR/L16		29	25	15.3	200	40	23		

▲更多型号可咨询, 可接受高要求非标定制

MFKR

MFKR

内径槽刀
Slotting tool

型号 Type	刀片 Blade	规格 Specification							螺丝 Screw	扳手 Wrench
		ϕ Dmin	ϕ d	L	H	min	max	Tmax		
MFKR16-25/80-2T8	MGMN200-M	17	16	160	14.8	25	80	8	M4X14	L3
MFKR20-30/80-2T10		21	20	180	18.4	30	80	10		
MFKR25-35/80-2T10		26	25	200	23.4	35	80	10		
MFKR20-30/80-3T12	MGMN300-M	21	20	180	18.4	30	80	12	M6X15C	L4
MFKR25-35/80-3T12		26	25	200	23.4	35	80	12		
MFKR20-30/80-4T12	MGMN400-M	21	20	180	18.4	30	80	12		
MFKR25-35/80-4T12		26	25	200	23.4	35	80	12		

▲更多型号可咨询, 可接受高要求非标定制

SGIVFR

SGIVFR

内径槽刀
Slotting tool

型号 Type	刀片 Blade	规格 Specification						螺丝 Screw	扳手 Wrench
		ϕ Dmin	ϕ d	f	L	L1	H		
SGIVFR16N16	GVFR□□	17	16	8	160	30	14.8	M4 x 10	T15
SGIVFR20Q16		21	20	10	180	30	18.4		
SGIVFR25R16		26	25	12.5	200	30	23.4		

▲更多型号可咨询, 可接受高要求非标定制

MFHR

MFHR

内径槽刀
Slotting tool

型号 Type	刀片 Blade	规格 Specification							螺丝 Screw	扳手 Wrench
		Dmin	ϕ d	L	H	min	max	Tmax		
MFHR216-20/140	MGMN200□□	17	16	160	14.8	20	140	6	M4X13	L3
MFHR320-25/140	MGMN300□□	21	20	180	18.4	25	140	6		
MFHR325-25/140		26	25	200	23.4	25	140	6		
MFHR332-35/140		MGMN400□□	33	32	250	30	35	140	10	M6X15C
MFHR420-25/140	21		20	180	18.4	25	140	6		
MFHR425-25/140	26		25	200	23.4	25	140	6		
MFHR432-35/140	33		32	250	30	35	140	10		

▲更多型号可咨询, 可接受高要求非标定制

MGIUR/L

用于越程槽和仿形加工
Used for over range groove and profiling processing

型号 Type	刀片 Blade	规格 Specification							螺丝 Screw	扳手 Wrench
		ϕD	ϕd	L	L1	Tmax	H	S		
MGIUR/L3520-3	MRMN300-M	35	20	150	45	3.5	18	13	M5 x 18	L4
MGIUR/L4025-3		40	25	200	45	3.5	23	15.5		
MGIUR/L5032-3		50	32	250	65	3.5	30	19		
MGIUR/L3520-4	MRMN400-M	35	20	150	45	3.5	18	13		
MGIUR/L4025-4		40	25	200	45	3.5	23	15.5		
MGIUR/L5032-4		50	32	250	65	3.5	30	19		
MGIUR/L4025-5	MRMN500-M	40	25	200	45	3.5	23	15.5	M6 x 20	L5
MGIUR/L5032-5		50	32	250	65	3.5	30	19		
MGIUR/L4025-6		40	25	200	45	3.5	23	19		
MGIUR/L5032-6	50	32	250	65	3.5	30	19			

▲更多型号可咨询, 可接受高要求非标定制

GHVR/L

内径槽刀
Slotting tool

型号 Type	刀片 Blade	规格 Specification						螺丝 Screw	扳手 Wrench		
		ϕD_{min}	ϕd	f	L	L1	H				
GHVR/L1310M11-A16	TC1102	13	16	6.5	30	150	15	M2.5 x 7	T8		
GHVR/L1613M11-A16		16	16	8	35	150	15				
GHVR/L1613M16-A16		16	16	8.5	35	150	15				
GHVR/L2016N16-16	TC16T3	20	16	11	35	160	15			M4 x 10	T15
GHVR/L2520Q16-16		25	20	13	38	180	18				
GHVR/L3125R16-16		31	25	16	50	200	23				

▲更多型号可咨询, 可接受高要求非标定制

SMBB

型号 Type	刀片 Blade	规格 Specification									扳手 Wrench
		H	W	H3	L	H1	H2	W1	B	M	
SMBB1626	SPB□□	16	12	26	86	43	13	30	5.3	3-M6	L5
SMBB2026		20	19				9				
SMBB2032		20	19	32	100	50	13	38			
SMBB2526		25	23	26	86	43	4	42			
SMBB2532		25	23	32	110	50	8	30			
SMBB3232		32	30			54	5				

▲更多型号可咨询, 可接受高要求非标定制

2020-□

带扁位刀套

型号 Type	规格 Specification			
	ϕD	b	h	L
1616-06	6	16	16	80
1616-07	7	16	16	80
1616-08	8	16	16	80
1616-10	10	16	16	80
2020-06	6	20	20	80
2020-07	7	20	20	80
2020-08	8	20	20	80
2020-10	10	20	20	80
2020-12	12	20	20	80
2020-14	14	20	20	80

▲更多型号可咨询, 可接受高要求非标定制

2020-□

圆孔刀套

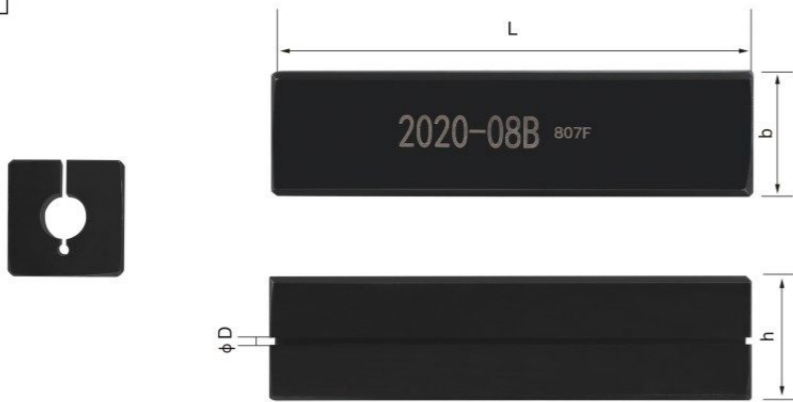

型号 Type	规格 Specification			
	φD	b	h	L
1616-06B	6	16	16	80
1616-07B	7	16	16	80
1616-08B	8	16	16	80
1616-10B	10	16	16	80
2020-06B	6	20	20	80
2020-07B	7	20	20	80
2020-08B	8	20	20	80
2020-10B	10	20	20	80
2020-12B	12	20	20	80

▲更多型号可咨询, 可接受高要求非标定制

SHB

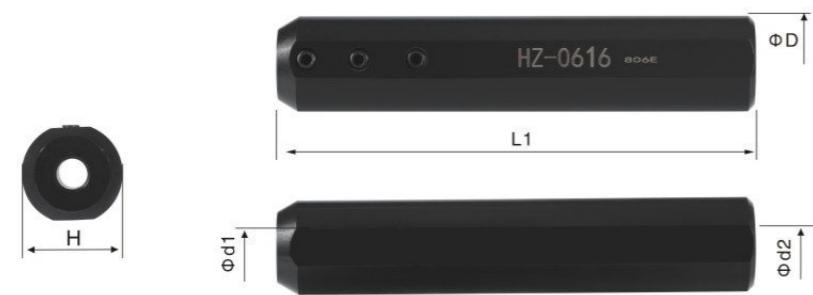

型号 Type	规格 Specification					螺丝 Screw	扳手 Wrench
	φD	φd1	φd2	H	L1		
SHB0416-100	16	4	5	14	100	HS4 x 4	L2
SHB0516-100		5	6				
SHB0616-100		6	7				
SHB0716-100		7	8				
SHB0820-120	20	8	9	18	120	HS4 x 4	L2
SHB1020-120		10	11				
SHB1225-150		12	13				
SHB1632-180	32	16	18	30	180	HS5 x 5	L2.5
SHB2032-180		20	22				

▲更多型号可咨询, 可接受高要求非标定制

CBSNR/L

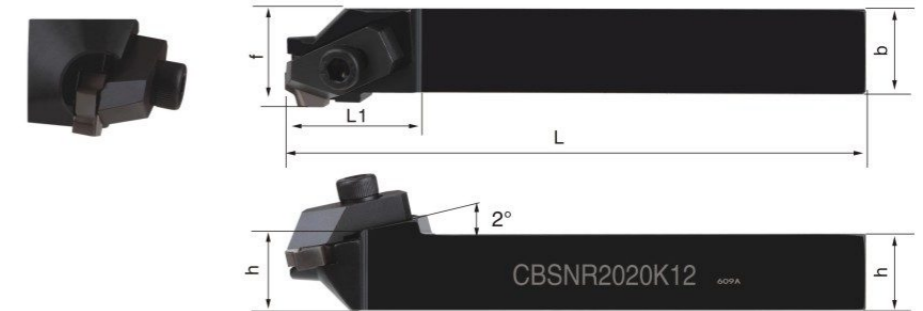
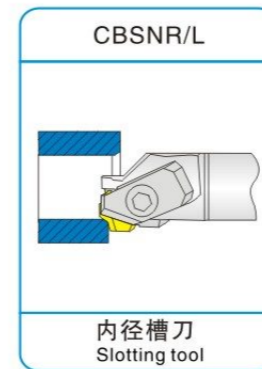

型号 Type	刀片 Blade	规格 Specification					压板 Clamp	螺丝 Screw	扳手 Wrench
		h	b	L	L1	f			
CBSNR/L2020K12	SNMF1204□□	20	20	125	32	20	CP-RCR	M6 x 20	L5
CBSNR/L2525M12		25	25	150	32	25			

▲更多型号可咨询, 可接受高要求非标定制

SBS

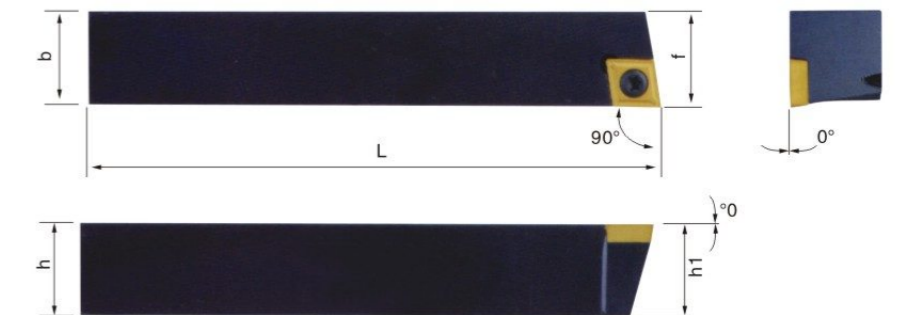
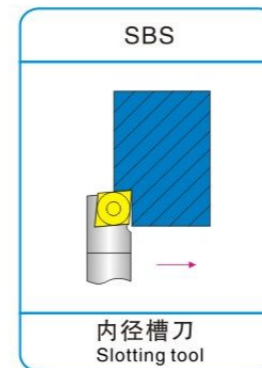

型号 Type	刀片 Blade	规格 Specification						螺丝 Screw	扳手 Wrench
		b	h	L	h1	f	L1		
SBS-108-CC06	CC□□0602□□	8	8	50	8	8	12	M2.5 x 7	T8
SBS-110-CC06		10	10	60	10	10	12		
SBS-113-CC09	CC□□09T3□□	13	13	80	13	13	15	M4 x 10	T15
SBS-116-CC09		16	16	100	16	16	15		
SBS-119-CC12	CC□□1204□□	19	19	125	19	19	22	M5 x 12	T20
SBS-125-CC12		25	25	150	25	25	22		

▲更多型号可咨询, 可接受高要求非标定制

SGS

内径槽刀
Slotting tool

型号 Type	刀片 Blade	规格 Specification						螺丝 Screw	扳手 Wrench
		b	h	L	h1	f	L1		
SGS-110-CC06	CC□□0602□□	10	10	60	10	12	12	M2.5 × 7	T8
SGS-113-CC09	CC□□09T3□□	13	13	80	13	16	15	M4 × 10	T15
SGS-116-CC09		16	16	100	16	20	15		
SGS-119-CC12	CC□□1204□□	19	19	125	19	23	20	M5 × 12	T20

▲更多型号可咨询, 可接受高要求非标定制

SBS

内径槽刀
Slotting tool

型号 Type	刀片 Blade	规格 Specification						螺丝 Screw	扳手 Wrench
		b	h	L	h1	f	L1		
SBS-408-CC06	CC□□0602□□	8	8	50	8	4.3	12	M2.5 × 7	T8
SBS-410-CC06		10	10	60	10	4.3	12		
SBS-413-CC09	CC□□09T3□□	13	13	80	13	6.4	15	M4 × 10	T15
SBS-416-CC09		16	16	100	16	6.4	15		
SBS-419-CC12	CC□□1204□□	19	19	125	19	8.5	22	M5 × 12	T20
SBS-425-CC12		25	25	150	25	6	22		

▲更多型号可咨询, 可接受高要求非标定制

SBS

内径槽刀
Slotting tool

型号 Type	刀片 Blade	规格 Specification						螺丝 Screw	扳手 Wrench
		b	h	L	h1	f	L1		
SBS-308-CC06	CC□□0602□□	8	8	50	8	3	12	M2.5 × 7	T8
SBS-310-CC06		10	10	60	10	3	12		
SBS-313-CC09	CC□□09T3□□	13	13	80	13	4.5	15	M4 × 10	T15
SBS-316-CC09		16	16	100	16	4.5	15		
SBS-316-CC12	CC□□1204□□	16	16	100	16	6	22	M5 × 12	T20
SBS-319-CC12		19	19	125	19	6	22		
SBS-325-CC12		25	25	150	25	6	22		

▲更多型号可咨询, 可接受高要求非标定制

SBS

内径槽刀
Slotting tool

型号 Type	刀片 Blade	规格 Specification						螺丝 Screw	扳手 Wrench
		b	h	L	h1	f	L1		
SBS-110-TC09	CC□□0902□□	10	10	60	10	19	12	M2.2 × 6	T6
SBS-113-TC11		13	13	80	13	13	15		
SBS-116-TC11	CC□□1102□□	16	16	100	16	16	15	M2.5 × 7	T8
SBS-116-TC16		16	16	100	16	16	20		
SBS-119-TC16	CC□□16T3□□	19	19	125	19	19	22	M4 × 10	T15
SBS-125-TC16		25	25	150	25	25	22		

▲更多型号可咨询, 可接受高要求非标定制

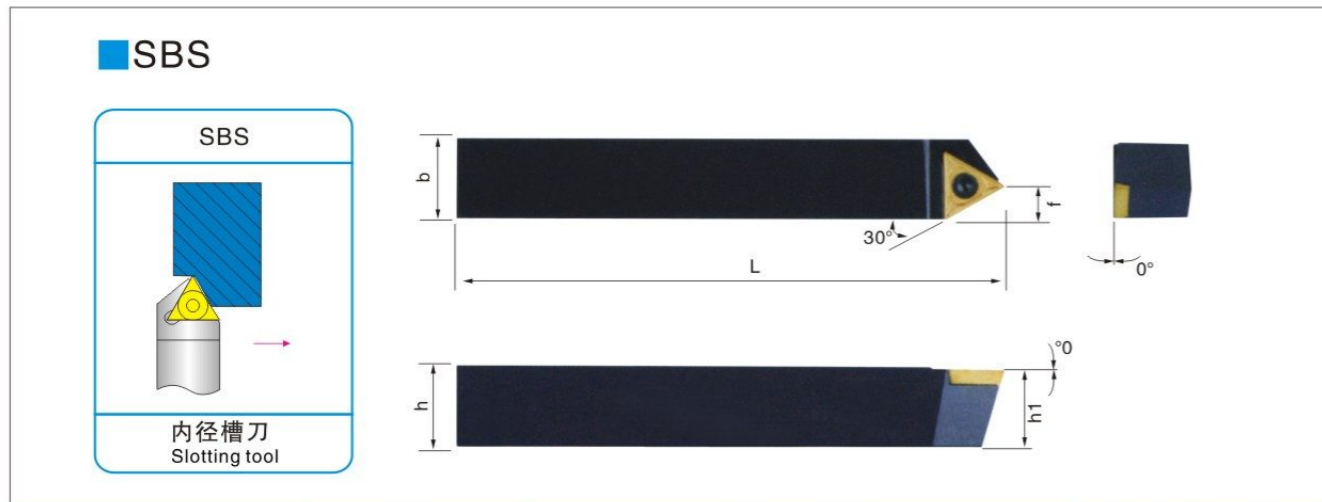

型号 Type	刀片 Blade	规格 Specification						螺丝 Screw	扳手 Wrench
		b	h	L	h1	f	L1		
SBS-310-TC09	CC□□0902□□	10	10	60	10	4.5	12	M2.2×6	T6
SBS-313-TC11		13	13	80	13	5.5	15		
SBS-316-TC11	CC□□1102□□	16	16	100	16	5.5	15	M2.5×7	T8
SBS-319-TC16		19	19	125	19	8	22		
SBS-325-TC16		25	25	150	25	8	22		

▲更多型号可咨询，可接受高要求非标定制

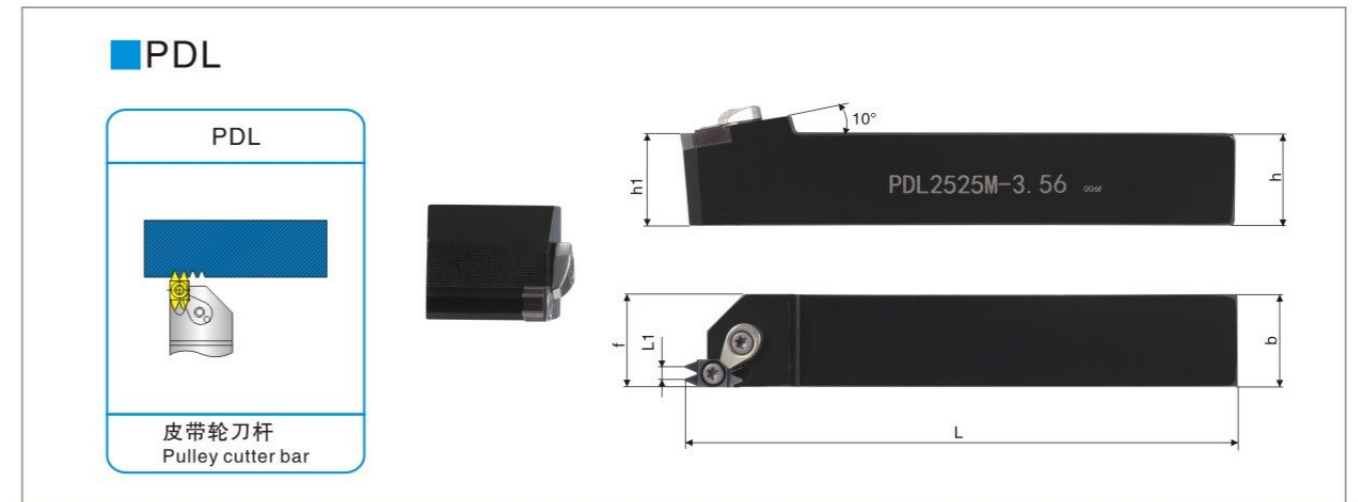

型号 Type	刀片 Blade	规格 Specification						螺钉 Screw	扳手 Wrench	压板 Clamp	压板螺钉 Plate screws
		h	b	L	L1	h1	f				
PDL2020K-2.34	PDL2B2.34	20	20	125	2.34	20	20	M4X10	T15	PD-0914	M4X10
PDL2525M-2.34		25	25	150	2.34	25	25				
PDL2020K-3.56	PDL2B3.56	20	20	125	3.56	20	20				
PDL2525M-3.56		25	25	150	3.56	25	25				

▲更多型号可咨询，可接受高要求非标定制

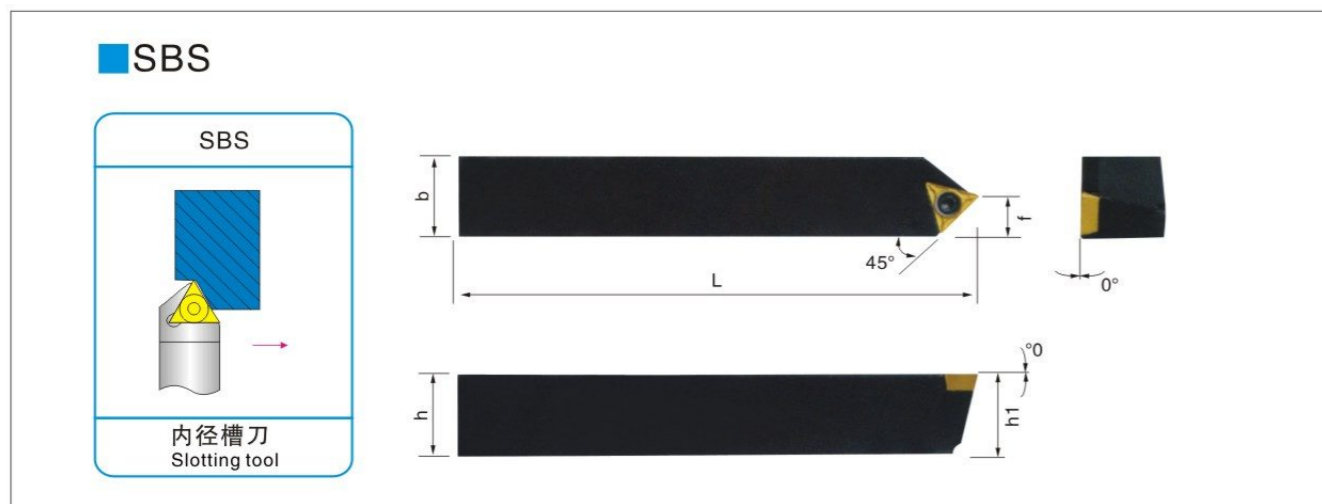

型号 Type	刀片 Blade	规格 Specification						螺丝 Screw	扳手 Wrench
		b	h	L	h1	f	L1		
SBS-410-TC09	CC□□0902□□	10	10	60	10	6.4	12	M2.2×6	T6
SBS-413-TC11		13	13	80	13	7.8	15		
SBS-416-TC11	CC□□1102□□	16	16	100	16	7.8	15	M2.5×7	T8
SBS-419-TC16		19	19	125	19	11.3	22		
SBS-425-TC16		25	25	150	25	11.3	22		

▲更多型号可咨询，可接受高要求非标定制

走心机槽刀系列

Centering machine slot cutter



JSDN3CR/L

主偏角62.5°
Tool cutting edge angle 62.5°

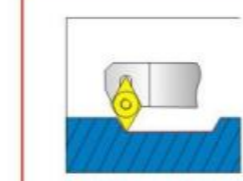

外圆车刀
Cylindrical turning tool

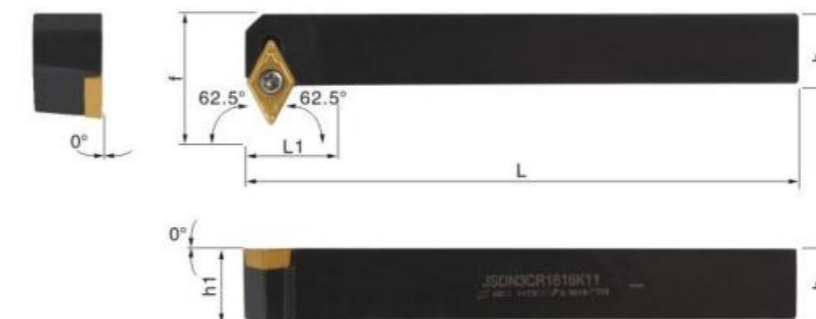

型号 Type	刀片 Blade	规格 Specification						螺丝 Screw	扳手 Wrench
		b	h	L	h1	f	L1		
JSDN3CR/L1212K07	DC□□11T3□□	12	12	125	12	18	12	M2.5 x 7	T8
JSDN3CR/L1616K11	DC□□11T3□□	16	16	125	16	25	15	M4 x 10	T15

▲更多型号可咨询, 可接受高要求非标定制

JSCL2CR/L

主偏角95°
Tool cutting edge angle 95°

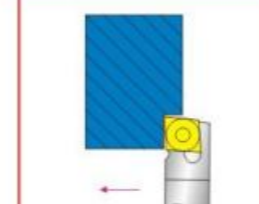

外圆车刀
Cylindrical turning tool



型号 Type	刀片 Blade	规格 Specification						螺丝 Screw	扳手 Wrench
		b	h	L	h1	f	L1		
JSCL2CR/L1010K06	CC□□0602□□	10	10	125	10	10	12	M2.5 x 7	T8
JSCL2CR/L1212K06		12	12	125	12	12	12		
JSCL2CR/L1010K09	CC□□09T3□□	10	10	125	10	10.5	16	M4 x 10	T15
JSCL2CR/L1212K09		12	12	125	12	12.5	16		

▲更多型号可咨询, 可接受高要求非标定制

JSDJ2CR/L

主偏角90°
Tool cutting edge angle 90°

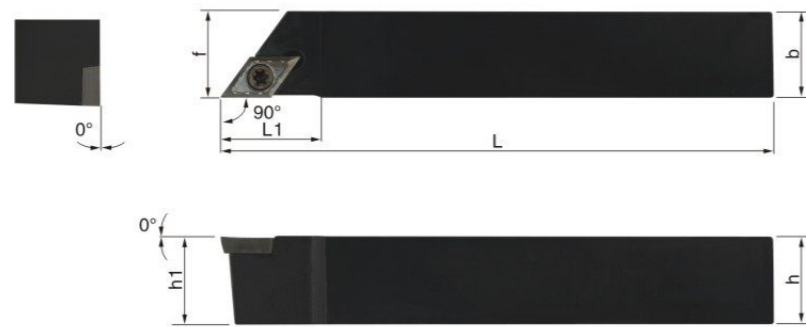
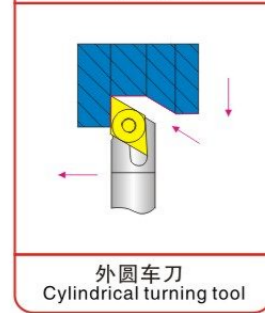

型号 Type	刀片 Blade	规格 Specification						螺丝 Screw	扳手 Wrench
		b	h	L	h1	f	L1		
JSDJ2CR/L1010K07	DC□□0702□□	10	10	125	10	10	16	M2.5×7	T8
JSDJ2CR/L1212K07		12	12	125	12	12	16		
JSDJ2CR/L1010K11	DC□□11T3□□	10	10	125	10	10.5	22	M4×10	T15
JSDJ2CR/L1212K11		12	12	125	12	12.5	22		

▲更多型号可咨询, 可接受高要求非标定制

SAB□R/L

SAB□R/L

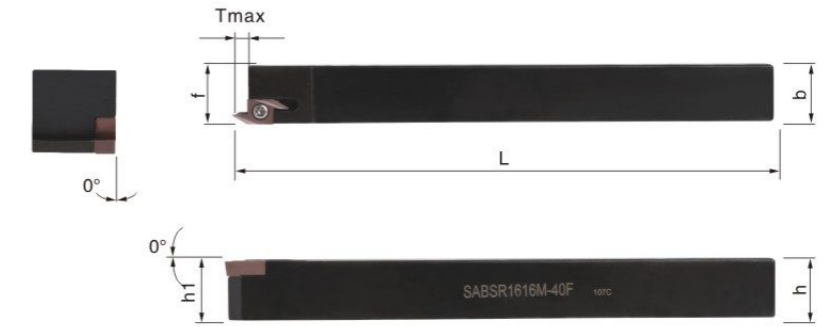
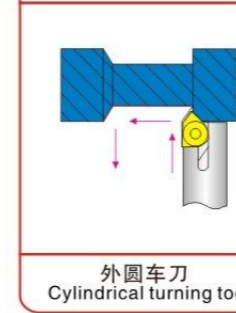

型号 Type	刀片 Blade	规格 Specification						螺丝 Screw	扳手 Wrench
		b	h	L	h1	f	Tmax		
SABSR1010K-40F	ABS15R/L40□□	10	10	125	10	10	4.2	M3×8	T8
SABSR1212K-40F		12	12	125	12	12	4.2		
SABWR1010K-40F	ABW15R/L40□□	10	10	125	10	10	8.2		
SABWR1212K-40F		12	12	125	12	12	8.2		
SABSR1616M-40F	ABS15R/L40□□	16	16	150	16	16	4.2		
SABSR2020M-40F		20	20	150	20	20	4.2		
SABWR/L1212K-50F	ABW23R/L50□□	12	12	125	12	12	8.2		
SABWR/L1616M-50F		16	16	150	16	16	8.2		
SABWR/L2020M-50F		20	20	150	20	20	8.2		

▲更多型号可咨询, 可接受高要求非标定制

JSVJ2□R/L

主偏角93°
Tool cutting edge angle 93°

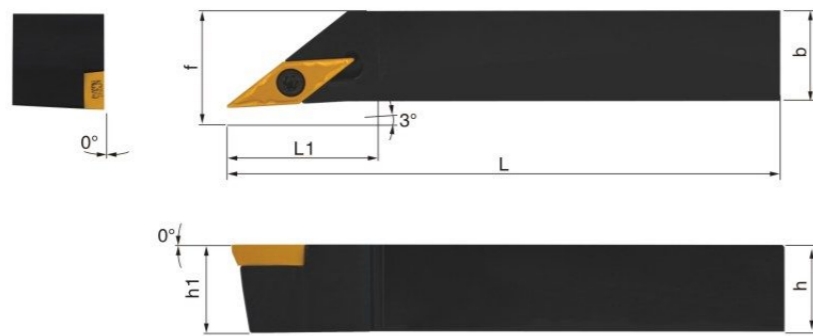
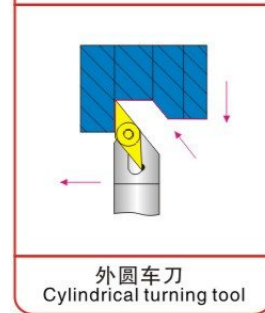

型号 Type	刀片 Blade	规格 Specification						螺丝 Screw	扳手 Wrench
		b	h	L	h1	f	L1		
JSVJ2CR/L1010K11	VC□□1103□□	10	10	125	10	10	23	M2.5×7	T8
JSVJ2CR/L1212K11		12	12	125	12	12	23		
JSVJ2BR/L1010K11	VB□□1103□□	10	10	125	10	10	23		
JSVJ2BR/L1212K11		12	12	125	12	12	23		

▲更多型号可咨询, 可接受高要求非标定制

CTPR/L

CTPR/L

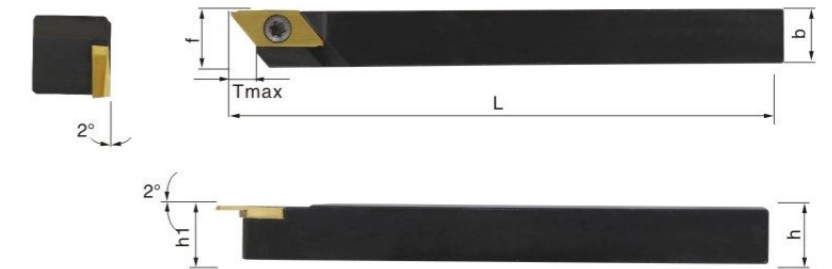
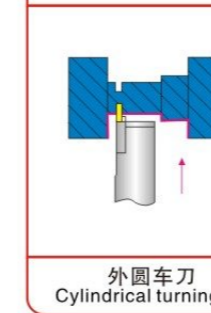

型号 Type	刀片 Blade	规格 Specification						螺丝 Screw	扳手 Wrench
		b	h	L	h1	f	Tmax		
CTPR/L08	CTP07-20FR/L□	8	8	120	8	8	5.5	M4×10	T15
CTPR/L10		10	10		10				
CTPR/L12		12	12		12				
CTPR/L16	CTPX15-20FR/L□	16	16	16					
CTPR/L20		20	20	20					

▲更多型号可咨询, 可接受高要求非标定制

TBPR/L

外圆车刀
Cylindrical turning tool

型号 Type	刀片 Blade	规格 Specification						螺丝 Screw	扳手 Wrench
		b	h	L	h1	f	Tmax		
TBPR/L08	TBP55FR/L□□	8	8	120	8	3.5	5.5	M4 x 10	T15
TBPR/L10		10	10	120	10	3.5	5.5		
TBPR/L12		12	12	120	12	3.5	5.5		
TBPR/L16		16	16	120	16	3.5	5.5		
TBPR/L20		20	20	120	20	3.5	5.5		

▲更多型号可咨询, 可接受高要求非标定制

KTKFR/L

外圆车刀
Cylindrical turning tool

型号 Type	刀片 Blade	规格 Specification						螺丝 Screw	扳手 Wrench
		b	h	L	h1	f	Tmax		
KTKFR/L1010JX-12	TKFB12R28	10	10	120	10	10	7	M4 x 10	T15
KTKFR/L1212JX-12		12	12	120	12	12	7		
KTKFR/L1616JX-12		16	16	120	16	16	7		
KTKFR/L2020JX-12		20	20	120	20	20	7		

▲更多型号可咨询, 可接受高要求非标定制

CTPAR/L

外圆车刀
Cylindrical turning tool

型号 Type	刀片 Blade	规格 Specification						螺丝 Screw	扳手 Wrench
		b	h	L	h1	f	Tmax		
CTPAR/L10	CTPA07~20FR/L□	10	10	120	10	10	4.5~9	M4 x 10	T15
CTPAR/L12		12	12	120	12	12	4.5~9		
CTPAR/L16		16	16	120	16	16	4.5~9		
CTPAR/L20F		20	20	80	20	20	4.5~9		

▲更多型号可咨询, 可接受高要求非标定制

KTKFR/L

外圆车刀
Cylindrical turning tool

型号 Type	刀片 Blade	规格 Specification						螺丝 Screw	扳手 Wrench
		b	h	L	h1	f	Tmax		
KTKFR/L1212JX-16	TKFB16R38	12	12	120	12	12	8	M4 x 10	T15
KTKFR/L1616JX-16		16	16	120	16	16	8		
KTKFR/L2020JX-16		20	20	120	20	20	8		

▲更多型号可咨询, 可接受高要求非标定制

TBPAR

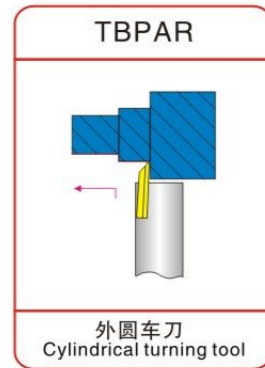

型号 Type	刀片 Blade	规格 Specification						螺丝 Screw	扳手 Wrench
		b	h	L	h1	f	Tmax		
TBPAR10	TBP60FR/L□□	10	10	120	10	4.5	7.5	M4 x 10	T15
TBPAR12		12	12	120	12	4.5	7.5		
TBPAR16		16	16	120	16	4.5	7.5		
TBPAR20		20	20	120	20	4.5	7.5		

▲更多型号可咨询, 可接受高要求非标定制

E-PTXNR

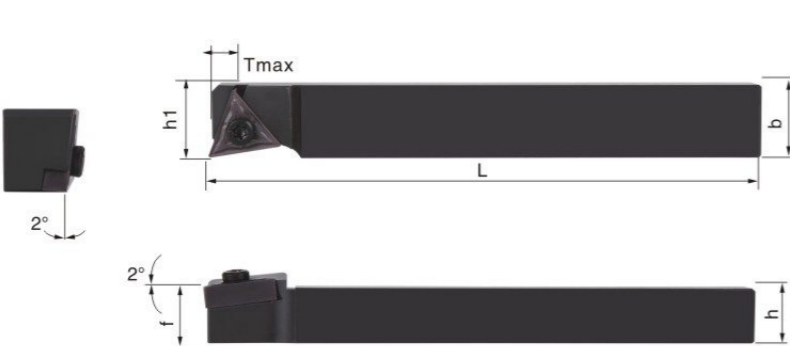
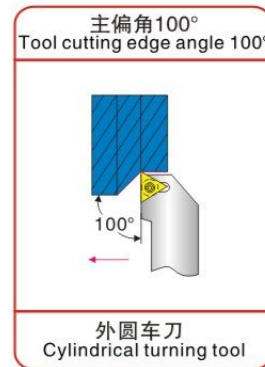

型号 Type	刀片 Blade	规格 Specification					螺丝 Screw	扳手 Wrench
		b	h	L	h1	f		
E-PTXNR1016X33N	TN□□33	10	16	120	10	16	M3.5 x 13T	T15
E-PTXNR1216X33N		12	16	120	12	16		
E-PTXNR1616X33N		16	16	120	16	16		
E-PTXNR2020X33N		20	20	120	20	20		

▲更多型号可咨询, 可接受高要求非标定制

TTER/L(特固克槽型)

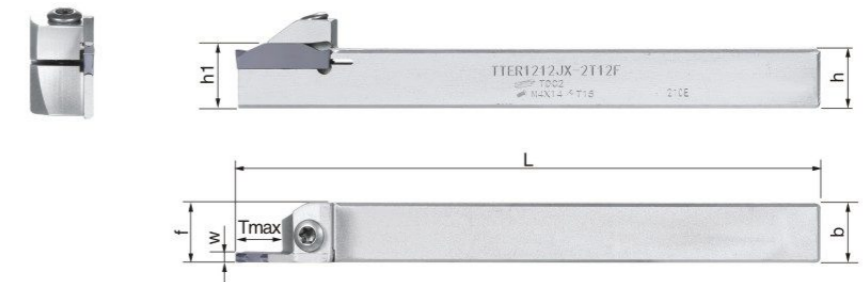
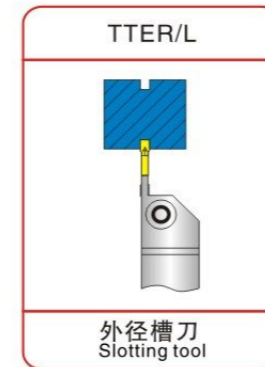

型号 Type	刀片 Blade	规格 Specification						螺丝 Screw	扳手 Wrench
		w	b	h	L	h1	Tmax		
TTER/L1010JX-2T12F	TDC2	2	10	10	120	10	24	M4 x 14	T15
TTER/L1212JX-2T12F		2	12	12	120	12	24	M4 x 14	T15
TTER/L1616JX-2T12F		2	16	16	120	16	24	M6 x 16	L5
TTER/L1212JX-3T12F	TDC3	3	12	12	120	12	24	M4 x 14	T15
TTER/L1616JX-3T12F		3	16	16	120	16	24	M6 x 16	L5

▲更多型号可咨询, 可接受高要求非标定制

KGMR/L(京瓷槽型)

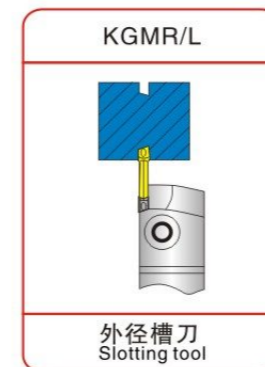

型号 Type	刀片 Blade	规格 Specification						螺丝 Screw	扳手 Wrench
		w	b	h	L	h1	Dmax		
KGMR/L1212JX-1.5T12F	GMM1520-MT	1.5	12	12	120	12	24	M4X14	T15
KGMR/L1616JX-1.5T12F		1.5	16	16	120	16	24	M6X16	L5
KGMR/L1212JX-2T12F	GMM2020-MT	2	12	12	120	12	24	M4X14	T15
KGMR/L1616JX-2T12F		2	16	16	120	16	24	M6X16	L5
KGMR/L1212JX-2.5T12F	GMM2520-MT	2.5	12	12	120	12	24	M4X14	T15
KGMR/L1616JX-2.5T12F		2.5	16	16	120	16	24	M6X16	L5
KGMR/L1212JX-3T12F	GMM3020-MT	3	12	12	120	12	24	M4X14	T15
KGMR/L1616JX-3T12F		3	16	16	120	16	24	M6X16	L5

▲更多型号可咨询, 可接受高要求非标定制

■ MGEHR/L □□

专利产品 专利号: 2L2013 2 0320 273.5

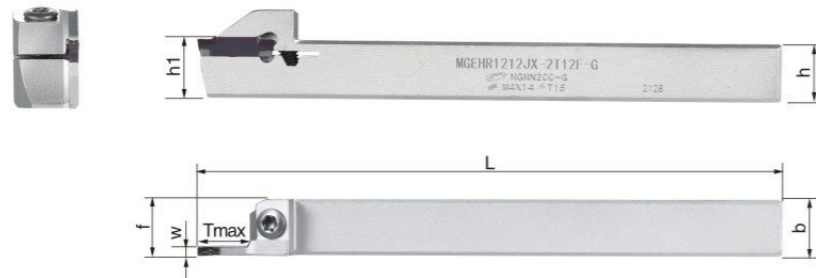
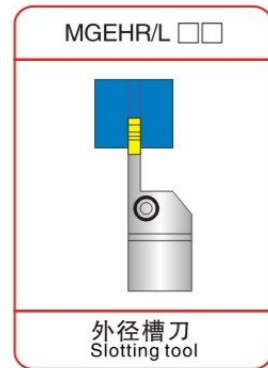

型号 Type	刀片 Blade	规格 Specification						螺丝 Screw	扳手 Wrench
		w	b	h	L	h1	Tmax		
MGEHR/L1010JX-1.5T12	MGMN150-M	1.5	10	10	120	10	24	M4 × 14	T15
MGEHR/L1212JX-1.5T12			12	12	120	12	24	M4 × 14	T15
MGEHR/L1212JX-1.5T12F			12	12	120	12	24	M4 × 14	T15
MGEHR/L1616JX-1.5T12			16	16	120	16	24	M6 × 16	L5
MGEHR/L1010JX-2T12	MGMN200-M	2	10	10	120	10	24	M4 × 14	T15
MGEHR/L1212JX-2T12			12	12	120	12	24	M4 × 14	T15
MGEHR/L1212JX-2T12F			12	12	120	12	24	M4 × 14	T15
MGEHR/L1616JX-2T12			16	16	120	16	24	M6 × 16	L5
MGEHR/L1010JX-2.5T12	MGMN250-M	2.5	10	10	120	10	24	M4 × 14	T15
MGEHR/L1212JX-2.5T12			12	12	120	12	24	M4 × 14	T15
MGEHR/L1212JX-2.5T12F			12	12	120	12	24	M4 × 14	T15
MGEHR/L1616JX-2.5T12			16	16	120	16	24	M6 × 16	L5
MGEHR/L1212JX-3T12	MGMN300-M	3	12	12	120	12	24	M4 × 14	T15
MGEHR/L1212JX-3T12F			12	12	120	12	24	M4 × 14	T15
MGEHR/L1616JX-3T12			16	16	120	16	24	M6 × 16	L5

▲更多型号可咨询, 可接受高要求非标定制

■ KTGFL

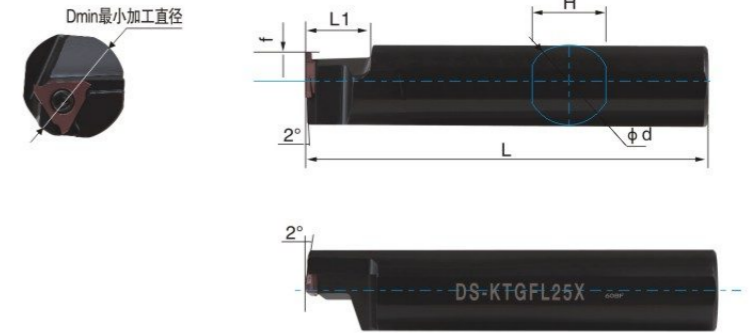
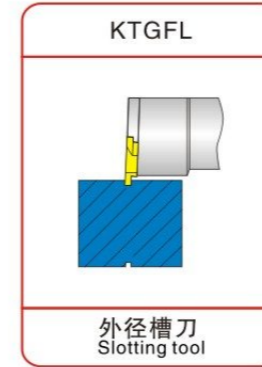

型号 Type	刀片 Blade	规格 Specification				螺丝 Screw	扳手 Wrench
		φ d	f	L1	H		
DS-KTGFL14H	TGF32R/L	14	6	20	13	M3.5 × 10	T15
DS-KTGFL15H		15.875	6		14.8		
DS-KTGFL16X		16	6		14.8		
DS-KTGFL19X		19.05	6		17.8		
DS-KTGFL20X		20	6		18.4		
DS-KTGFL22X		22	6		20		
DS-KTGFL25X		25.4	10		23.4		

▲更多型号可咨询, 可接受高要求非标定制

■ SDUCR/L

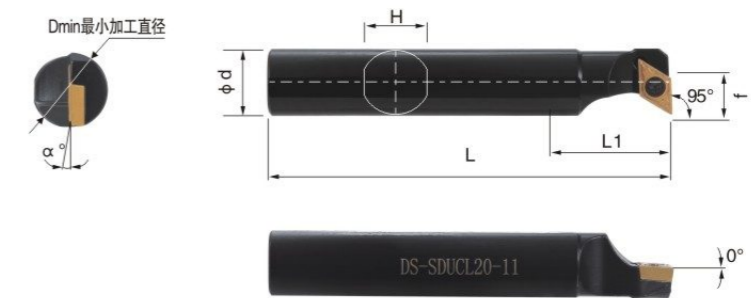
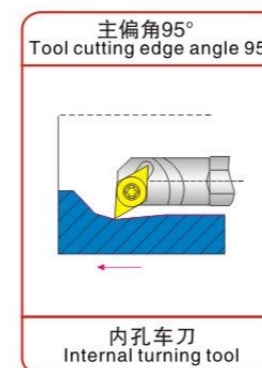

型号 Type	刀片 Blade	规格 Specification						螺丝 Screw	扳手 Wrench
		φ Dmin	φ d	L	L1	H	α°		
DS-SDUCL14-07	DC□□0702□□	13	14	100	25	13	0°	M2.5 × 6	T8
DS-SDUCL16-07		14.8	16	120	25	14.8	0°		
DS-SDUCL20-07		18.4	20	120	25	18.4	0°		
DS-SDUCL16-11	DC□□11T3□□	14.8	16	120	25	14.8	0°	M4 × 10	T15
DS-SDUCL20-11		18.4	20	120	25	18.4	0°		
DS-SDUCL22-11		20	22	120	25	20	0°		

▲更多型号可咨询, 可接受高要求非标定制

KTKFSL

外径槽刀
Slotting tool

型号 Type	刀片 Blade	规格 Specification							螺丝 Screw	扳手 Wrench
		h	b	L	L1	h1	f	Tmax		
KTKFSL1212K12	TKFB12	12	12	125	15	12	22.5	7	M4 x 8	T15
KTKFSL1616K12		16	16	125	15	16	25	7		
KTKFSL2020K12		20	20	125	15	20	27.5	7		

▲更多型号可咨询, 可接受高要求非标定制

CTPASL

外径槽刀
Slotting tool

型号 Type	刀片 Blade	规格 Specification							螺丝 Screw	扳手 Wrench
		h	b	L	L1	h1	f	Tmax		
CTPASL12	CTPA20	12	12	125	15	12	25.5	7	M4 x 8	T15
CTPASL16		16	16	125	15	16	27	7		
CTPASL20		20	20	125	15	20	30	7		

▲更多型号可咨询, 可接受高要求非标定制

CTPSL

外径槽刀
Slotting tool

型号 Type	刀片 Blade	规格 Specification							螺丝 Screw	扳手 Wrench
		h	b	L	L1	h1	f	Tmax		
CTPSL12	CTP20	12	12	125	15	12	21	6	M4 x 8	T15
CTPSL16		16	16	125	15	16	24	6		
CTPSL20		20	20	125	15	20	26	6		

▲更多型号可咨询, 可接受高要求非标定制

代号 Code	刀片形状 Shape of blade	
H	正六角形 Regular hexagon	
O	正八角形 Regular octagon	
P	正五角形 Regular pentagon	
S	正方形 Square	
T	正三角形 Regular triangle	
C	菱形顶角80° Rhombus vertex angle 80°	
D	菱形顶角55° Rhombus vertex angle 55°	
E	菱形顶角75° Rhombus vertex angle 75°	
F	菱形顶角50° Rhombus vertex angle 50°	
M	菱形顶角86° Rhombus vertex angle 86°	
V	菱形顶角35° Rhombus vertex angle 35°	
W	等边不等角六角形 Equilateral hexagon with unequal angle	
L	长方形 Rectangle	
A	平行四边形顶角85° Parallelogram vertex angle 85°	
B	平行四边形顶角82° Parallelogram vertex angle 82°	
K	平行四边形顶角55° Parallelogram vertex angle 55°	
R	圆形 Round	

① 形状代号 Shape code

注带修光刀刀片的情况(铣刀用)
Note the condition of Wiper blade (Used in milling cutter)

精度代号 Precision code				(参考)M级精度详细情况(按形状、大小分) ● 刀尖高度公差(mm) (Reference) Details of M-grade precision (according to shape, size) ● Height allowance of tool nose (mm)						
代号 Code	刀尖高度公差m(mm) Height of tool nose Allowance	内接圆公差 φD1(mm) Incircle allowance	厚度公差 S,(mm) Thickness allowance	内接圆 Incircle	正三角形 Regular triangle	正方形 Square	80°菱形 80° rhombus	55°菱形 55° rhombus	35°菱形 35° rhombus	圆形 Round
A	±0.005	±0.025	±0.025	6.35	±0.08	±0.08	±0.08	±0.11	±0.18	-
F	±0.005	±0.013	±0.025	9.525	±0.08	±0.08	±0.08	±0.11	±0.16	-
C	±0.013	±0.025	±0.025	12.70	±0.13	±0.13	±0.13	±0.15	-	-
H	±0.013	±0.013	±0.025	15.875	±0.15	±0.15	±0.15	±0.18	-	-
E	±0.025	±0.025	±0.025	19.05	±0.15	±0.15	±0.15	±0.18	-	-
G	±0.025	±0.025	±0.13	25.40	-	±0.18	-	-	-	-
J	±0.005	±0.05-±0.15	±0.025	31.75	-	±0.20	-	-	-	-
K*	±0.013	±0.05-±0.15	±0.025	● 内接圆 φD1的公差(mm) Incircle φD1 allowance (mm)						
L*	±0.025	±0.05-±0.15	±0.025	6.35	±0.05	±0.05	±0.05	±0.05	±0.05	-
M*	±0.08-±0.18	±0.05-±0.15	±0.13	9.525	±0.05	±0.05	±0.05	±0.05	±0.05	±0.05
N*	±0.08-±0.18	±0.05-±0.15	±0.025	12.70	±0.08	±0.08	±0.08	±0.08	-	±0.08
U*	±0.13-±0.38	±0.08-±0.25	±0.13	15.875	±0.10	±0.10	±0.10	±0.10	-	±0.10
				19.05	±0.10	±0.10	±0.10	±0.10	-	±0.10
				25.40	-	±0.13	-	-	-	±0.13
				31.75	-	±0.15	-	-	-	±0.15

印*表示其侧面不研磨的刀片
Marking * means the blade with unpolished side

③ 精度代号 Precision code

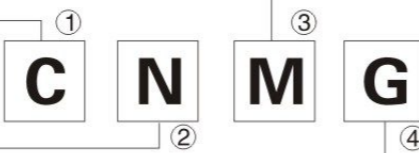

② 后角代号 Relief angle code	
代号 Code	后角(度) Relief angle (degree)
A	3
B	5
C	7
D	15
E	20
F	25
G	30
N	0
P	11
O	其他的后角 Other relief angles

后角是指对主切削刃法向后角
Relief angle refers to normal relief angle of main cutting edge

④ 槽、孔代号 Groove and bore code									
公制 Metric system									
代号 Code	有无孔 Have or no bore	孔的形状 Shape of bore	有无断屑槽 Have or no chip breaker groove	刀片剖面 Blade section	代号 Code	有无孔 Have or no bore	孔的形状 Shape of bore	有无断屑槽 Have or no chip breaker groove	刀片剖面 Blade section
W	有 Have	圆柱孔+单面倒角(40-60°) Cylindric bore + Single-sided chamfer(40-60°)	无 No		A	有 Have	圆柱孔 Cylindric bore	无 No	
T	有 Have	圆柱孔+单面倒角(40-60°) Cylindric bore + Single-sided chamfer(40-60°)	单面 Single side		M	有 Have	圆柱孔 Cylindric bore	单面 Single side	
Q	有 Have	圆柱孔+双面倒角(40-60°) Cylindric bore + Double-sided chamfer(40-60°)	无 No		G	有 Have	圆柱孔 Cylindric bore	双面 Double side	
U	有 Have	圆柱孔+双面倒角(40-60°) Cylindric bore + Double-sided chamfer(40-60°)	双面 Double side		N	无 No	-	无 No	
B	有 Have	圆柱孔+单面倒角(70-90°) Cylindric bore + Single-sided chamfer(70-90°)	无 No		R	无 No	-	单面 Single side	
H	有 Have	圆柱孔+单面倒角(70-90°) Cylindric bore + Single-sided chamfer(70-90°)	单面 Single side		F	无 No	-	双面 Double side	
C	有 Have	圆柱孔+双面倒角(70-90°) Cylindric bore + Double-sided chamfer(70-90°)	无 No		X	-	-	-	特殊 Special
J	有 Have	圆柱孔+双面倒角(70-90°) Cylindric bore + Double-sided chamfer(70-90°)	双面 Double side						

刀片形状 Shape of blade							内接圆 Incircle (mm)
R	W	V	D	C	S	T	
	02		04	03	03	06	3.97
	L3	08	05	04	04	08	4.76
	03	09	06	05	05	09	5.56
06							6.00
	04	11	07	06	06	11	6.35
	05	13	09	08	07	13	7.94
08							8.0
09	06	16	11	09	09	16	9.525
10							10.00
12							12.00
12	08	22	15	12	12	22	12.70
	10		19	16	15	27	15.875
16							16.00
19	13		23	19	19	33	19.05
20							20.00
			27	22	22	38	22.225
25							25.00
25			31	25	25	44	25.40
31			38	32	31	54	31.75
32							32.00

⑤ 切削刃长度代号和内接圆代号 Length code of cutting edge and incircle code

⑤ 切削刃长度代号和内接圆代号 Length code of cutting edge and incircle code



⑦ 刀尖圆弧代号 Tool nose arc code	
代号 Code	圆弧头半径(mm) Radius of arc head (mm)
00	无圆角 No fillet
V3	0.03
V5	0.05
01	0.1
02	0.2
04	0.4
08	0.8
12	1.2
16	1.6
20	2.0
24	2.4
28	2.8
32	3.2

刀片直径尺寸
00(英制) M0(公制)
Diameter of blade
00(british system) M0(metric system)

圆形刀片 Circular blade

⑧ 刃口处理代号 Cutting edge handling code		
形状 Shape	刃口修磨 Polishing of cutting edge	代号 Code
	尖锐刀刃 Sharp blade	F
	倒圆刀刃 Rounding blade	E
	倒棱刀刃 Chamfering blade	T
	双重处理刀刃 Double-handling blade	S

本公司省略了刃口修磨代号
The company omits the code of polishing of cutting edge

⑨ 切削方向代号 Code of cutting direction		
形状 Shape	切削方向 Cutting Direction	代号 Code
	右手 Right hand	R
	左手 Left hand	L
	Left Right	N

*厚度指刀片底面与切削刃最高部分之间的高度。
thickness of blade and the bottom surface of the cutting edge portion between the height of the highest

代号 Code	刀片厚度(mm) Blade thickness
S1	1.39
01	1.59
T0	1.79
02	2.38
T2	2.78
03	3.18
T3	3.97
04	4.76
06	6.35
07	7.94
09	9.52

⑥ 刀片厚度代号 Blade thickness Code

⑩ 刀片断屑槽代号 Chip breaker groove code of blade		
无代号 No code	C	ES
FH	FJ	FS
FV	GH	GJ
HV	HX	HZ
MA	MH	MJ
MS	MV	MW
SA	SH	SW