

PRODUCT CATALOGUE 2023



**INNOVATING BEYOND
PIONEERING AHEAD**

-  86-0576-86970099
-  echo@wencerl.com
-  www.wencerl.com
-  Qianyangxia Village, Wenqiao Town, Wenling City, Zhejiang Province, the PRC



P13-20

刀具组合图
Diagram of cutting tool group



P21-73

外圆车刀
Cylindrical turning tool



P118-122

阻尼深孔车刀
Deep turning damping



P74-117

内孔车刀
Internal turning tool



P123-132

螺纹车刀
Threading tool



P133-172

切槽刀
Slotting tool



P185-186

刀片编制说明
Preparation description for blades



P173-184

走心机槽刀
Centering machine slot knife



目录 CATALOG









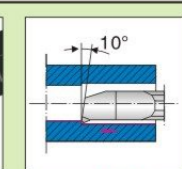
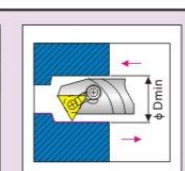

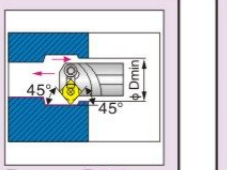

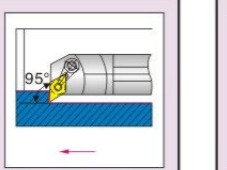

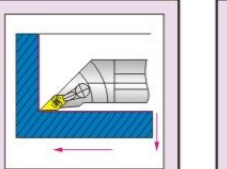
Classic Comes from Speciality
世界品质 源于专业

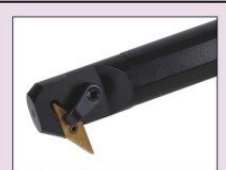
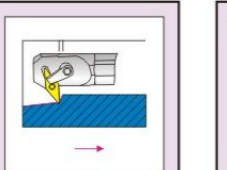

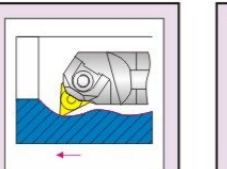

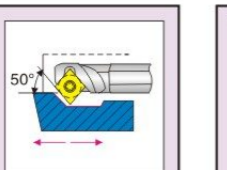

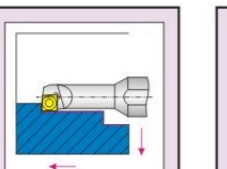

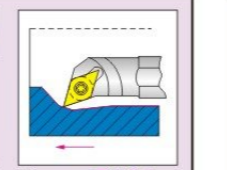

 □CFNR/L Page-P23	 □CLNR/L Page-P24	 □CBNR/L Page-P25	 □TJNR/L Page-P44	 □TENN Page-P45	 □TWRN/L Page-P46
 □CKNR/L Page-P26	 □CSNR/L Page-P27	 □CGNR/L Page-P28	 □TWRN/L-B Page-P46	 □VJNR/L Page-P47	 □VQNR/L Page-P48
 □CMNN-80 Page-P29	 □CMNN-100 Page-P30	 □DPNN Page-P31	 □VUNR/L Page-P49	 □VVNN Page-P50	 □WLNR/L Page-P51
 □DJNR/L Page-P32	 □DQNR/L Page-P33	 □DFNR/L Page-P34	 □WENN Page-P52	 □WWNR/L Page-P52	 □WWNR/L-B Page-P53
 □SBNR/L Page-P35	 □SDNN Page-P36	 □SKNR/L Page-P37	 WWLNR/L Page-P53	 SCLCR/L Page-P54	 SCKCR/L Page-P54
 □SRNR/L Page-P38	 □SSNR/L Page-P39	 □TQNR/L Page-P40	 SCFCR/L Page-P55	 SCMCN Page-P55	 SCMCN-100 Page-P56
 □TFNR/L Page-P41	 □TGNR/L Page-P42	 □TBNR/L Page-P43	 SCGCR/L Page-P56	 SCBCR/L Page-P57	 SCACR/L Page-P57



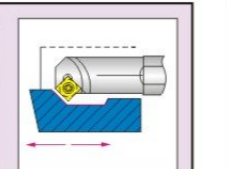

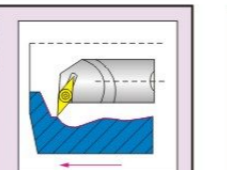

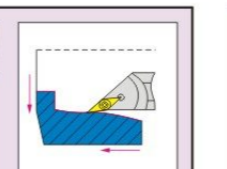

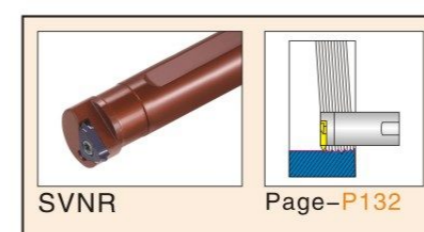
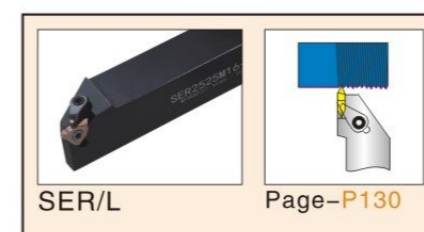
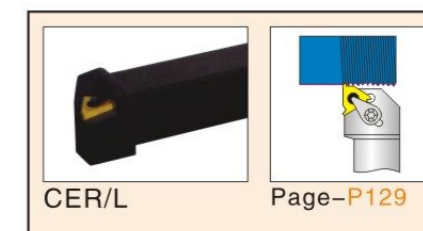
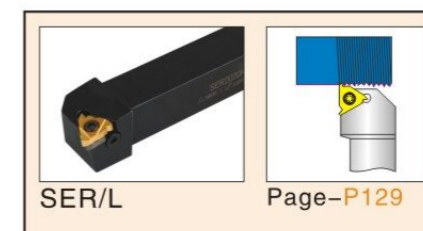
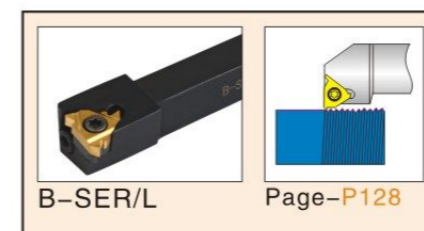
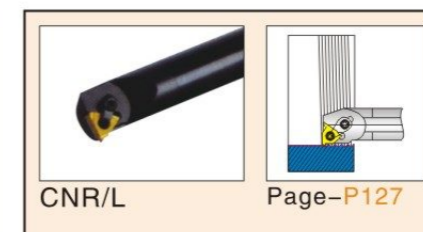
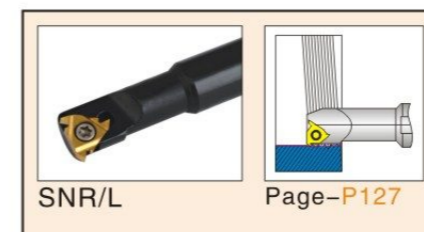
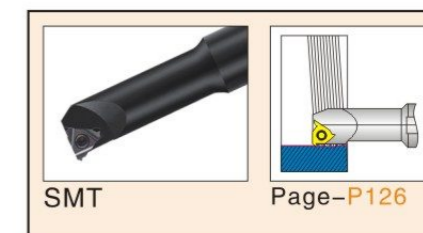
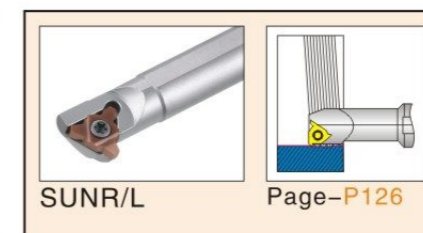
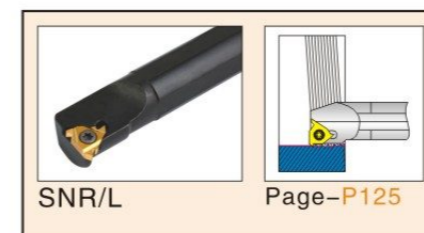
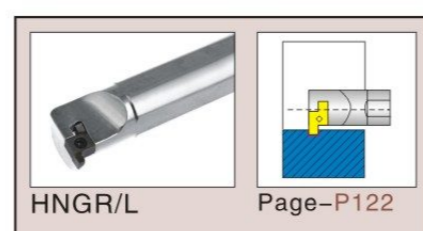
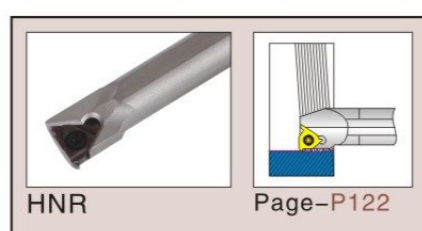
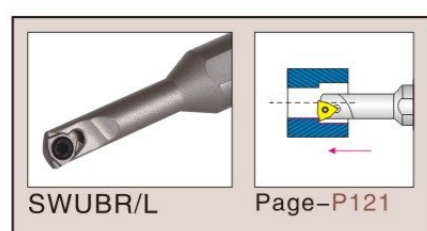
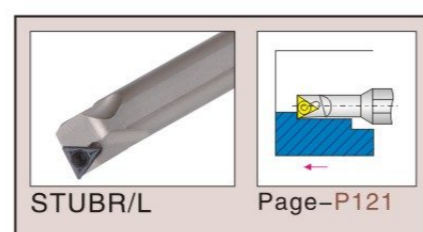
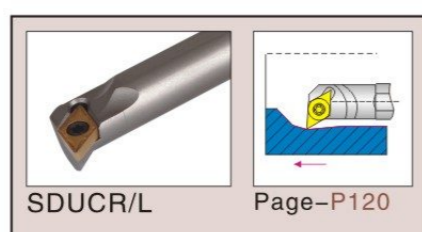
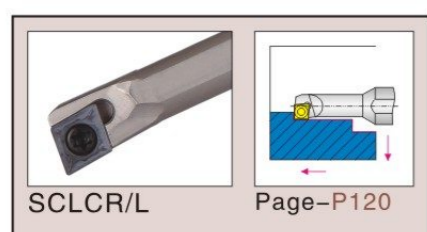
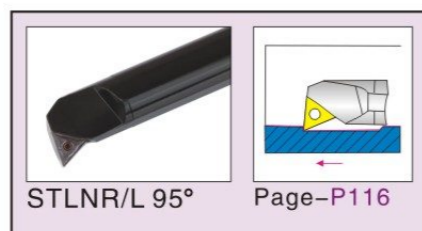
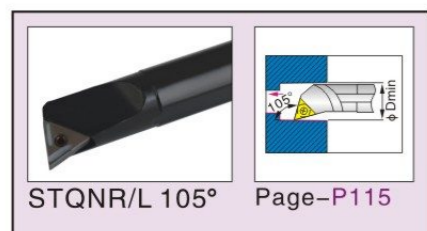
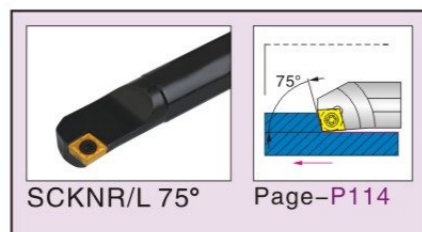
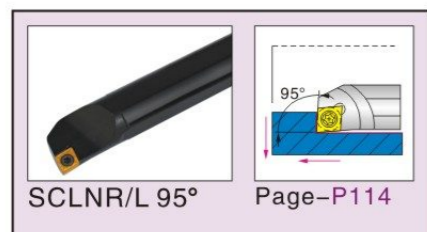
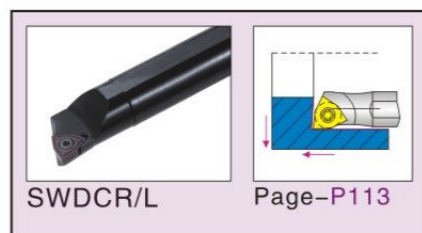
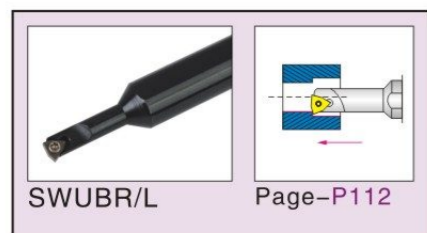

















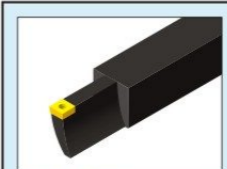







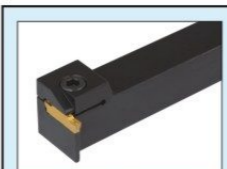

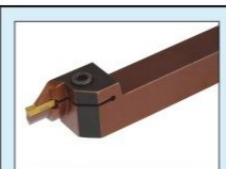
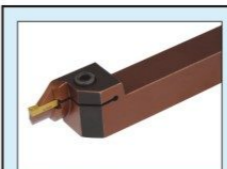
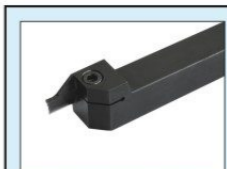
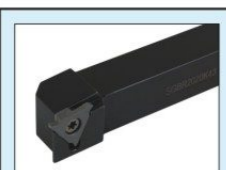
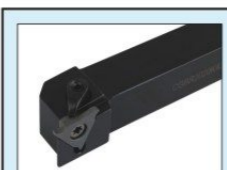
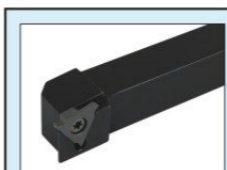
 SDJCR/L	 Page-P58	 SDACR/L	 Page-P58	 SDFCR/L	 Page-P59
 SDQCR/L	 Page-P59	 SDNCN	 Page-P60	 SSBCR/L	 Page-P60
 SDWCR/L	 Page-P61	 SDZCR/L	 Page-P61	 SSKCR/L	 Page-P62
 SSSCR/L	 Page-P62	 SSDCN	 Page-P63	 STFCR/L	 Page-P63
 STGCR/L	 Page-P64	 STWCR/L	 Page-P64	 STECR/L	 Page-P65
 SVJ*R/L	 Page-P65	 SVV*N	 Page-P66	 SVQ*R/L	 Page-P66
 SVU*R/L	 Page-P67	 SVWBR/L	 Page-P67	 SVZBR/L	 Page-P68



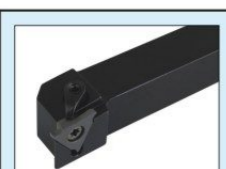

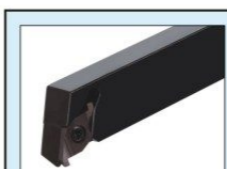

 SRAPR/L	 Page-P68	 SRDPN	 Page-P69	 SRDCN	 Page-P69
 SRGPR/L	 Page-P70	 SRACR/L	 Page-P70	 SRGCR/L	 Page-P71
 HAOR	 Page-P71	 GTTR/L	 Page-P72	 SVNR	 Page-P72
 SVNR	 Page-P73	 CKBR	 Page-P73	 CLNR/L	 Page-P76
 CKNR/L	 Page-P77	 CWNR/L	 Page-P78	 TJNR/L	 Page-P79
 TFNR/L	 Page-P80	 TWNRL	 Page-P81	 TUNRL	 Page-P82
 TQNR/L	 Page-P83	 TLNR/L	 Page-P83	 SKNR/L	 Page-P84

 □SSNR/L Page-P85	 □DQNR/L Page-P86	 □DWRN/L Page-P87
 □DUNR/L Page-P88	 □DZNR/L Page-P89	 □VQNR/L Page-P90
 □VXNR/L Page-P91	 □VUNR/L Page-P92	 □VWNR/L Page-P93
 □VZNR/L Page-P93	 □WLNR/L Page-P94	 2MWR Page-P95
 □TUNR/L 93° Page-P96	 □WLNR/L Page-P96	 SCLCR/L Page-P97
 SCWCR/L Page-P98	 SCKCR/L Page-P98	 SCZCR/L Page-P99
 SCLCR/L 95° Page-P99	 SCKCR/L 75° Page-P100	 SDUCR/L Page-P100

 SDQCR/L Page-P101	 SDZCR/L Page-P101	 SDWCR/L Page-P102
 SDXCR/L Page-P102	 STUBR/L Page-P103	 STU□R/L 93° Page-P103
 STUCR/L Page-P104	 STFCR/L Page-P105	 STUPR/L Page-P106
 STFPR/L Page-P106	 STWCR/L Page-P107	 STWPR/L Page-P107
 SSSCR/L Page-P108	 SSKCR/L Page-P108	 SVQ*R/L Page-P109
 SVU*R/L Page-P109	 SVW*R/L Page-P110	 SVX*R/L Page-P110
 SVJ*R/L Page-P111	 SVZ*R/L Page-P111	 SWLCR/L Page-P112



 ZQ□□R/L Page-P134	 MGEHR/L □□ Page-P135	 MGEHR/L □□ (加长切深) Page-P136	 SGEL Page-P147	 SGESR Page-P148	 □□□SR/L Page-P148
 CGWSR/L (东芝槽型) Page-P137	 QE□DR/L (株洲槽型) Page-P137	 R-MGEHR/L Page-P138	 □□□SR/L Page-P149	 SPB Page-P149	 STFPR Page-P150
 TTER/L Page-P138	 KGMR/L (京瓷槽型) Page-P139	 R/L 123□□ (山特维克槽型) Page-P140	 SMGB226 Page-P150	 SSACN Page-P151	 STC Page-P151
 DGTR/L□□ (伊斯卡槽型) Page-P140	 A4SMR/L (肯纳槽型) Page-P141	 GNDLR/L (住友槽型) Page-P141	 STACR/L Page-P152	 SRAPR/L Page-P152	 MGFVR/L Page-P153
 GYHR (三菱槽型) Page-P142	 MGEVR/L Page-P143	 MGEUR (退刀槽加工用) Page-P144	 FGHH Page-P154	 MGHH Page-P155	 QFFD/QFGD Page-P157
 SGB□□R/L Page-P144	 CGB□□R/L Page-P145	 KTGFR/L Page-P145	 QFHD/QFHS QFKD/QFKS Page-P158	 SNGR/L Page-P159	 SIGER/L Page-P160
 CTGFR/L Page-P146	 PCHR/L Page-P146	 SVQBR/L Page-P147	 MGIVR/L Page-P161	 TTIR Page-P162	 Q□DR/L Page-P162

 KTGFR/L Page-P163	 SGIVFR Page-P163	 MFKR Page-P164
 MFHR Page-P164	 MGIUR/L Page-P165	 GHVR/L Page-P165
 SMBB Page-P166	 2020-□ 带扁位刀套 Page-P166	 2020-□ 圆孔刀套 Page-P167
 SHB Page-P167	 CBSNR/L Page-P168	 SBS Page-P168
 SGS Page-P169	 SBS Page-P169	 SBS Page-P170
 SBS Page-P170	 SBS Page-P171	 SBS Page-P171
 PDL Page-P172		

 JSDN3CR/L Page-P174	 JSCL2CR/L Page-P174	 JSDJ2CR/L Page-P175
 JSVJ2□R/L Page-P175	 SAB□R/L Page-P176	 CTPR/L Page-P176
 TBPR/L Page-P177	 CTPAR/L Page-P177	 KTKFR/L Page-P178
 KTKFR/L Page-P178	 TBPAR Page-P179	 E-PTXNR Page-P179
 TTER/L Page-P180	 KGMR/L (京瓷槽型) Page-P180	 MGEHR/L □□ Page-P181
 KTGFL Page-P182	 SDUCR/L Page-P182	 KTKFSL Page-P183
 CTPSL Page-P183	 CTPASL Page-P184	

D-type

D

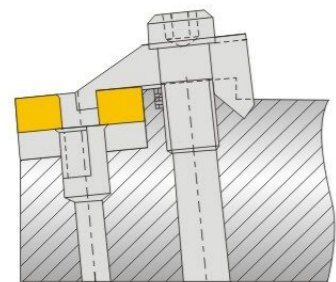
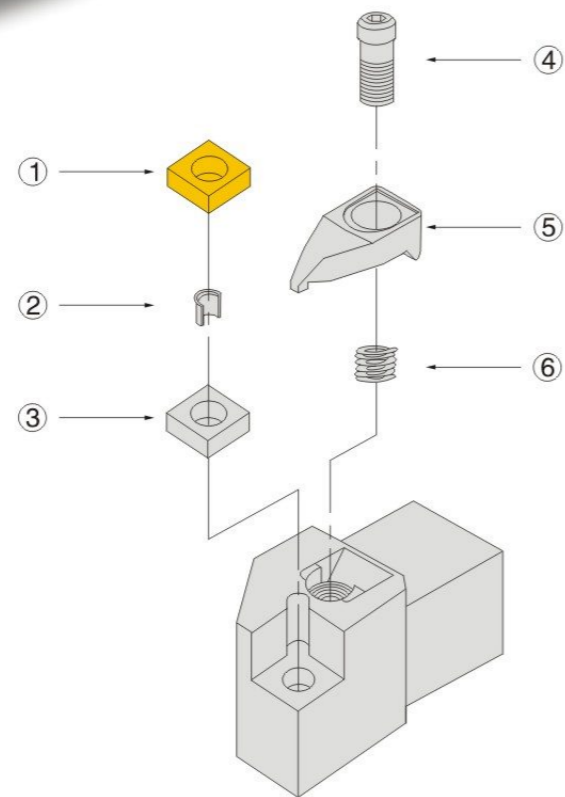

- ① 刀片 Blade
- ② C型环 C-type ring
- ③ 垫片 Gasket
- ④ 压板螺丝 Holddown plate screw
- ⑤ 压板 Holddown plate
- ⑥ 压板弹簧 Holddown plate spring

M-type

M

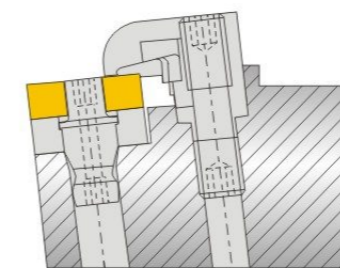
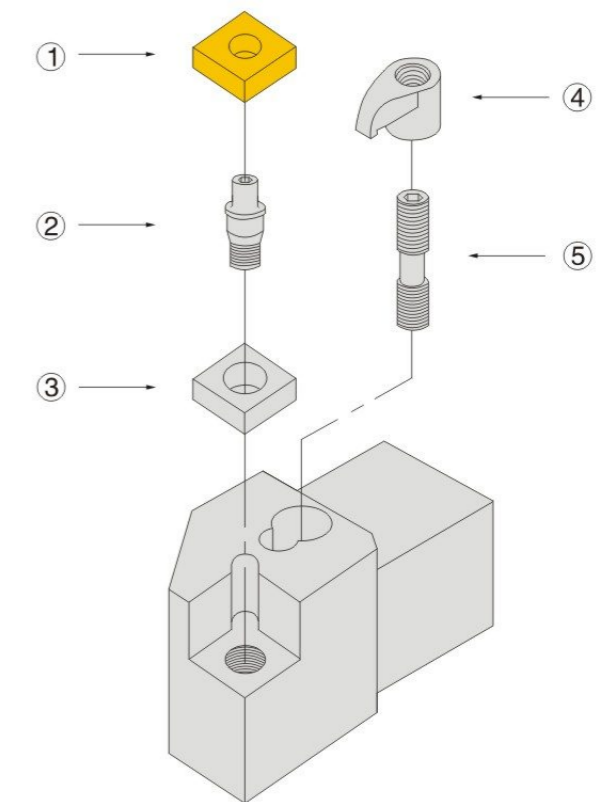

- ① 刀片 Blade
- ② 垫片螺絲 Screw washer
- ③ 垫片 Gasket
- ④ 压板 Holddown plate
- ⑤ 压板螺丝 Holddown plate screw

Z-type

Z

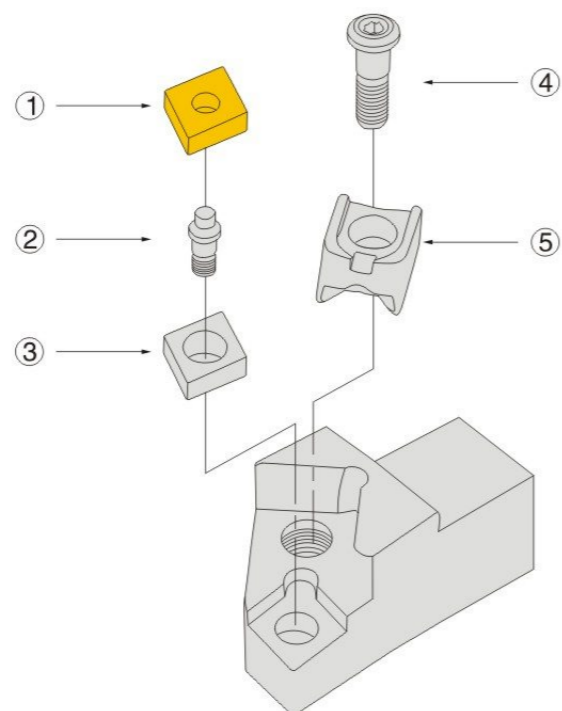

- ① 刀片 Blade
- ② 垫片螺絲 Screw washer
- ③ 垫片 Gasket
- ④ 压板螺絲 Holddown plate screw
- ⑤ 压板 Holddown plate

W-type

W

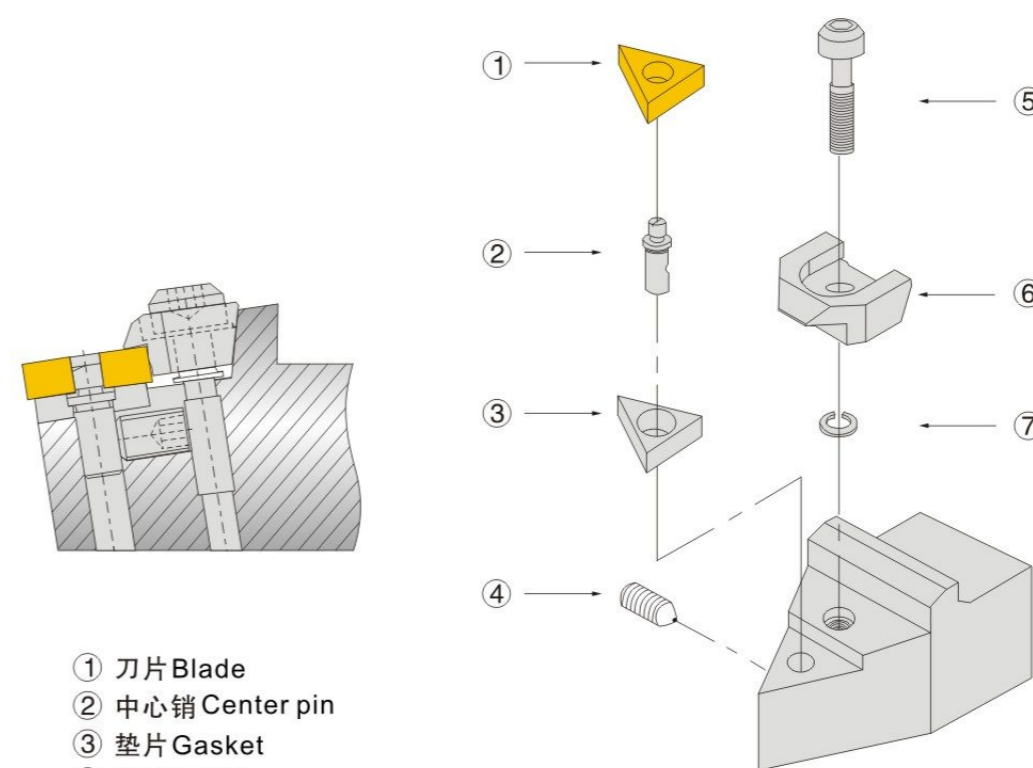
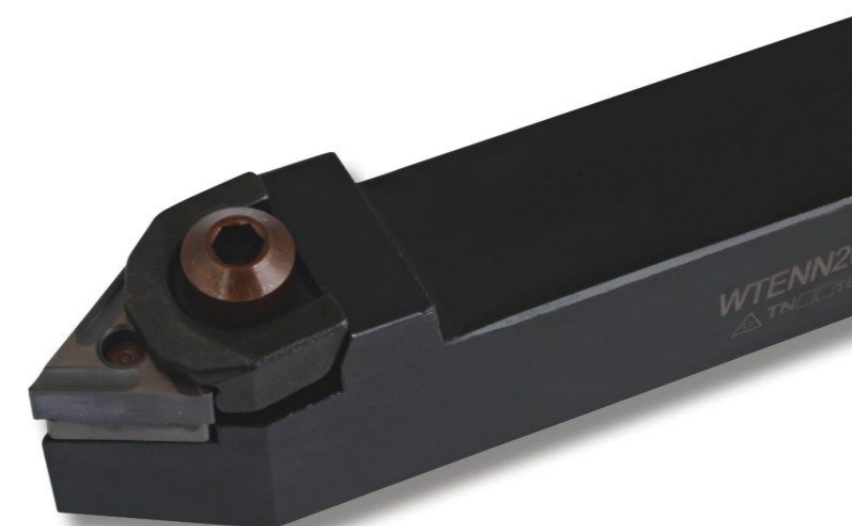

- ① 刀片 Blade
- ② 中心销 Center pin
- ③ 垫片 Gasket
- ④ 侧螺絲 Side screw
- ⑤ 压板螺絲 Holddown plate screw
- ⑥ 压板 Holddown plate
- ⑦ 弹簧 Spring

P-type

P

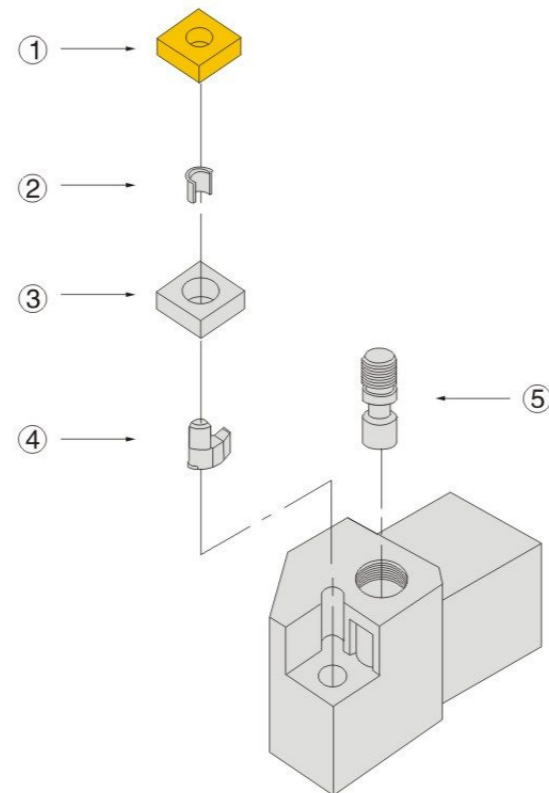

- ① 刀片 Blade
- ② C型环 C-type ring
- ③ 垫片 Gasket
- ④ L型钩 L-type hook
- ⑤ 螺丝 Screw

S-type, JS-type

S, JS

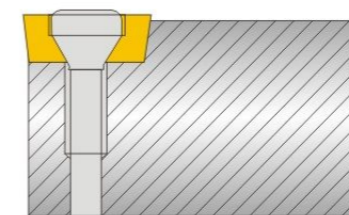
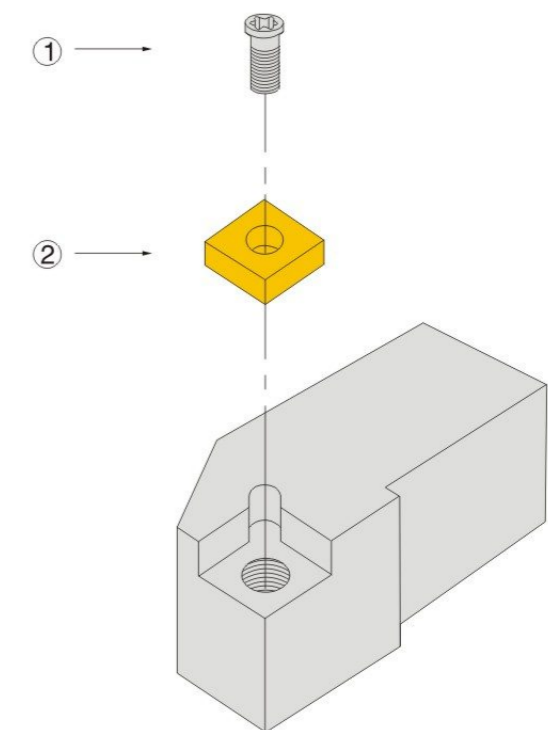

- ① 螺丝 Screw
- ② 刀片 Blade

CER/L

CE

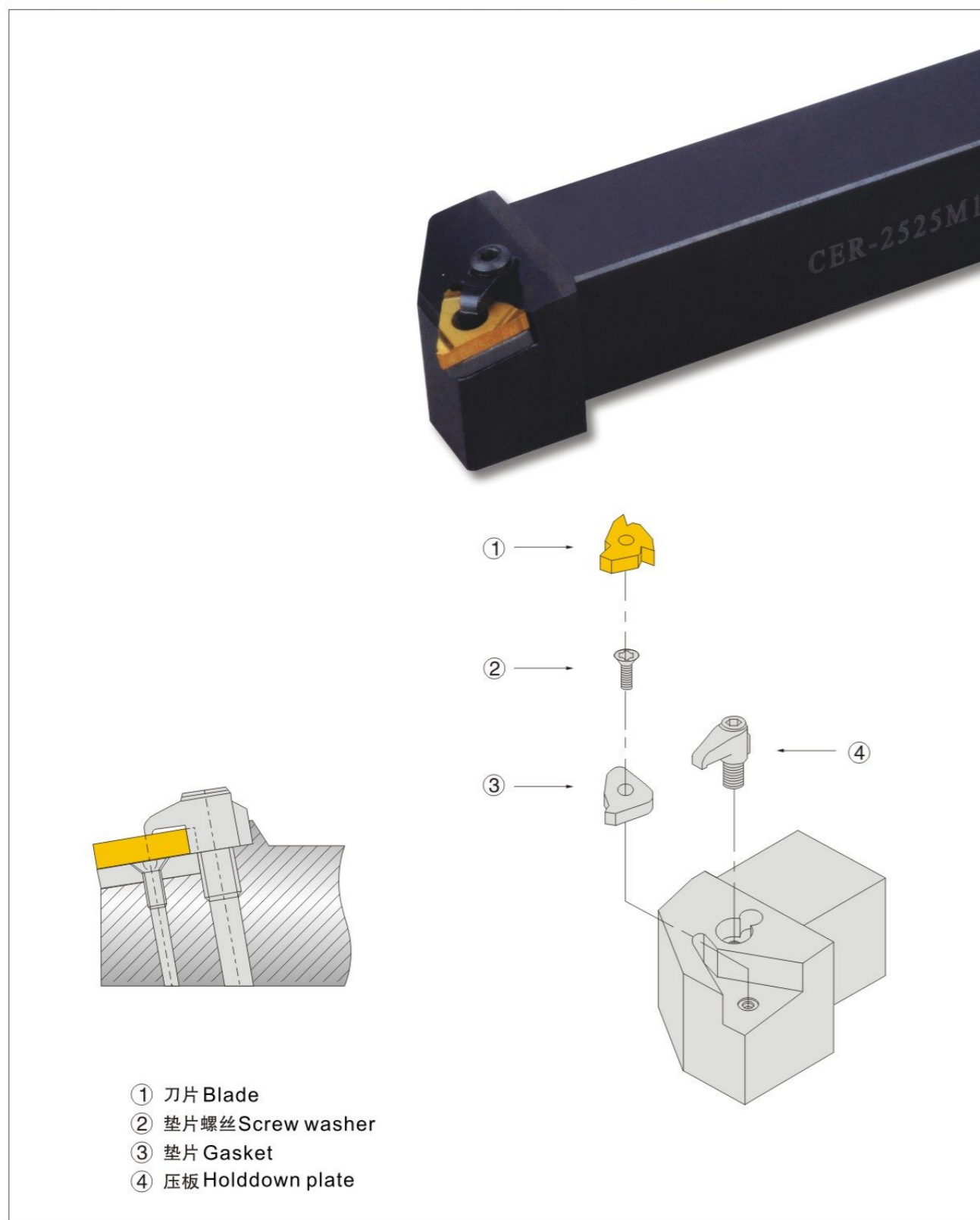

SER/L

SE

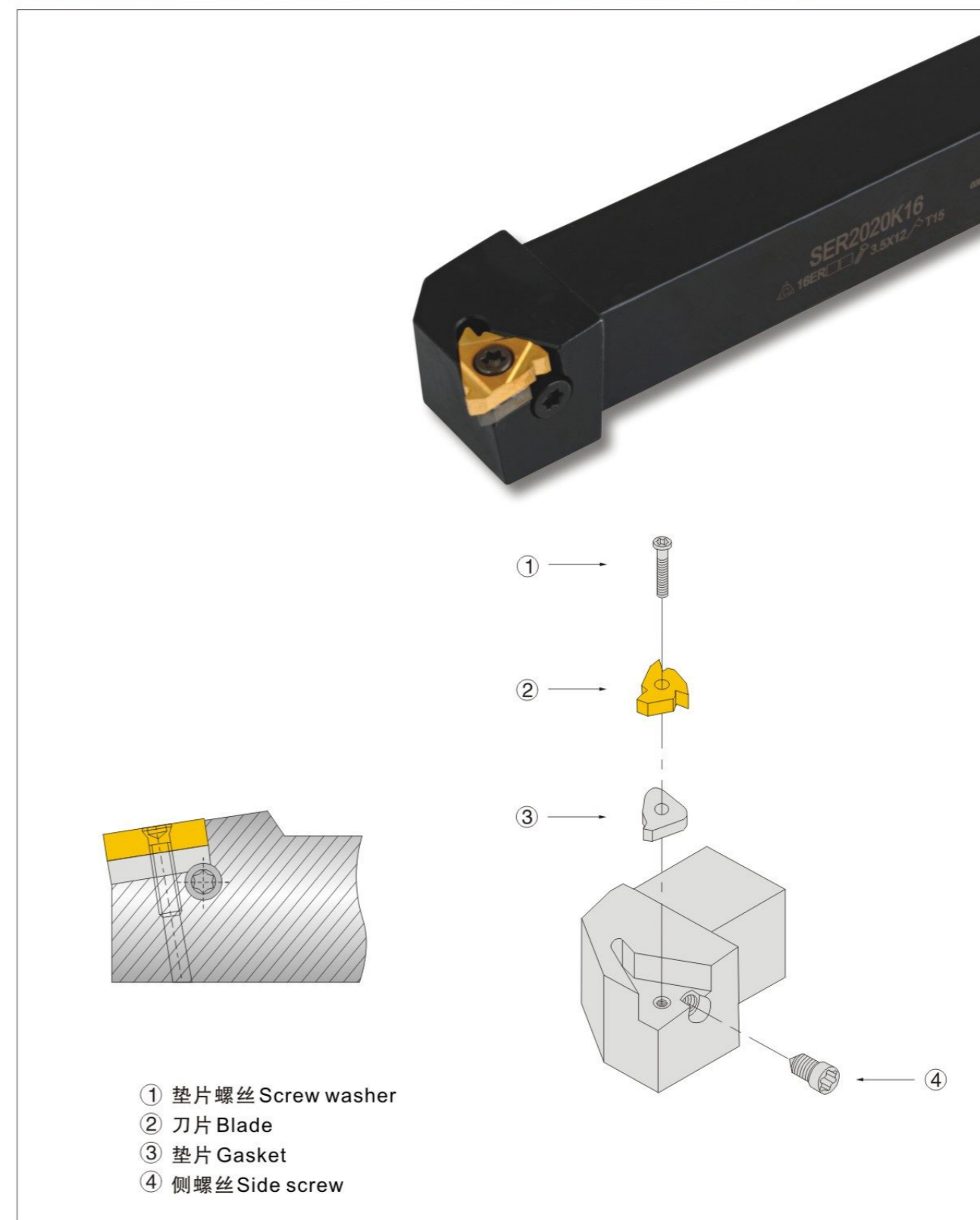

外圆车刀系列

Cylindrical turning tool

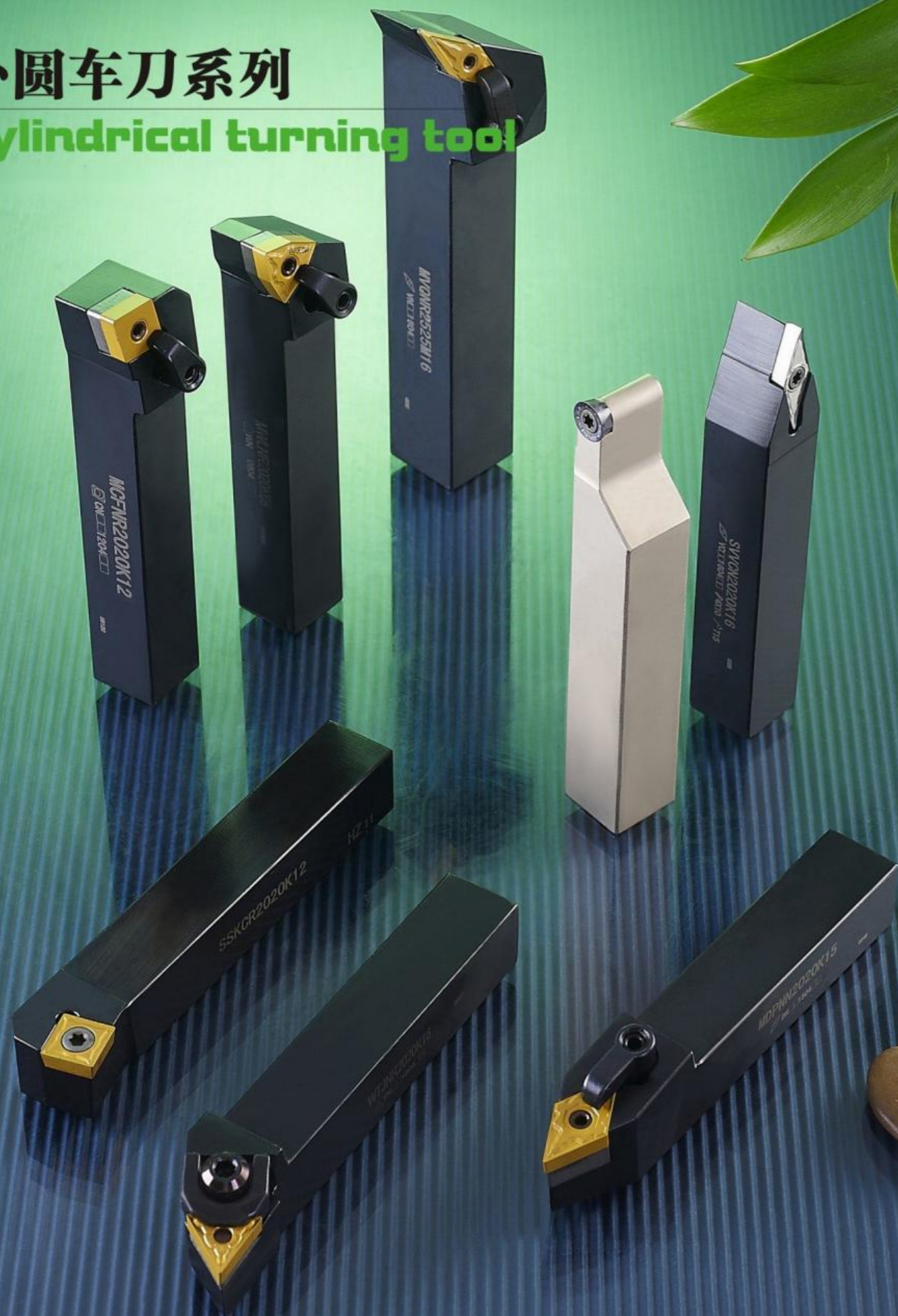

3					切入角 Cut-in angle				
A	B	C	D	E	F	G	J	J2	
90°	75°	90°	45°	60°	91°	91°	93°	93°	93°
					75°	95°	95°	63°	63°
					K	L	L2	N	N3
					62.5°	45°	45°	72.5°	90°
					P	Q	S	V	U
					100°	80°	93°		
X	Y	Z							

1					夹紧方式 Fastening mode				
A-type型号	E-type型号	Q-type型号	C-type型号	JS-type型号	M-type型号	P-type型号	S-type型号		

12
9

9	切刃长 Length of cutting blade	
	内切圆直径 Diameter of inscribed circle (mm)	
3	9.525	
4	12.7	
5	15.875	
6	19.05	
8	25.4	

M
8

8	长度 (mm) Length	H 100	K 125	M 150	P 170	R 200
---	----------------------	-------	-------	-------	-------	-------

25
7

7	宽度h(mm) Width	
6	高度h(mm) Height	

25
6

R
5

5	方向 Direction			
		L	N	R

N
4

4	刀片退屑角 Relief angle of blade				
		C	B	N	P

3
L

C
2

M

2	刀片形状 Shape of blade								
		四边形 顶角80°	四边形 顶角55°	平行四边形 顶角55°	圆形	正方形	正三角形	四边形 顶角35°	特殊六角形
		Quadrangle Vertex angle 80°	Quadrangle Vertex angle 55°	Parallelogram Vertex angle 55°	Round	Square	Regular triangle	Quadrangle Vertex angle 35°	Special hexagon

MCFNR/L

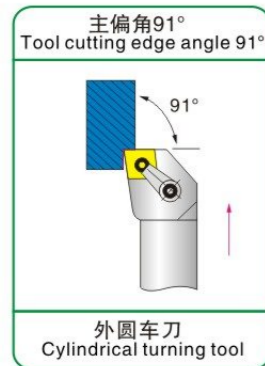

型号 Type	刀片 Blade	规格 Specification						刀垫 Shim	销钉 Pin	压板 Clamp	双头螺丝 Screw	扳手 Wrench
		h	b	L	L1	h1	f					
MCFNR/L2020K12	CN□□1204□□	20	20	125	32	20	25	MC1204	CTM617	HL1813	ML0625	L3.0
MCFNR/L2525M12		25	25	150	32	25	32					
MCFNR/L3232P12		32	32	170	32	32	40					
MCFNR/L3232P19	CN□□1906□□	32	32	170	36	32	40	MC1904	CTM1022	HL2217	ML0830	L4.0

型号 Type	刀片 Blade	规格 Specification						刀垫 Shim	压板螺钉 Plate screws	压板 Clamp	刀垫螺钉 Shim screw	扳手 Wrench
		h	b	L	L1	h1	f					
DCFNR/L2020K12	CN□□1204□□	20	20	125	32	20	25	MC1204	M6×21	HLD-1	M6×9P	L3.0
DCFNR/L2525M12		25	25	150	32	25	32					
DCFNR/L3232P12		32	32	170	32	32	40					

型号 Type	刀片 Blade	规格 Specification						刀垫 Shim	销钉 Pin	压板 Clamp	螺钉 Screw	扳手 Wrench
		h	b	L	L1	h1	f					
ZCFNR/L2020K12	CN□□1204□□	20	20	125	32	20	25	MC1204	CT618-Z	HLZ-C	M8×25	L3.0 L4.0
ZCFNR/L2525M12		25	25	150	32	25	32					
ZCFNR/L3232P12		32	32	170	32	32	40					

▲更多型号可咨询，可接受高要求非标定制

MCLNR/L

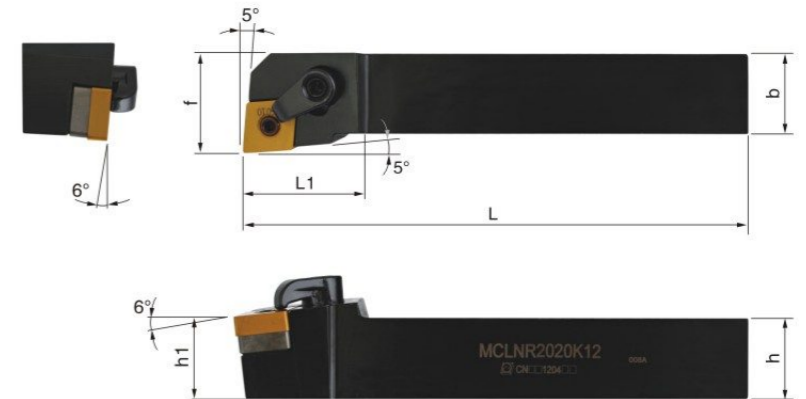
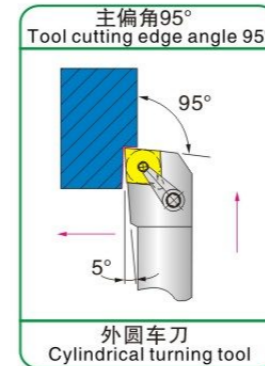

型号 Type	刀片 Blade	规格 Specification						刀垫 Shim	销钉 Pin	压板 Clamp	双头螺丝 Screw	扳手 Wrench
		h	b	L	L1	h1	f					
MCLNR/L1616H12	CN□□1204□□	16	16	100	32	16	20	MC1204	CTM617	HL1813	ML0625	L3.0
MCLNR/L2020K12		20	20	125	30	20	25					
MCLNR/L2525M12		25	25	150	31	25	32					
MCLNR/L3232P12		32	32	170	33	32	40					
MCLNR/L4040R12		40	40	200	35	40	50					
MCLNR/L2525M16	CN□□1606□□	25	25	150	37	25	32	MC1604	CTM822	HL2217	ML0830	L3.0 L4.0
MCLNR/L3232P16		32	32	170	36	32	40					
MCLNR/L4040R16		40	40	200	36	40	50					
MCLNR/L3232P19		32	32	170	39	32	40					
MCLNR/L4040R19	CN□□1906□□	40	40	200	39	40	50	MC1904	CTM1022	HL2217	ML0830	L4.0

型号 Type	刀片 Blade	规格 Specification						刀垫 Shim	压板螺钉 Plate screws	压板 Clamp	刀垫螺钉 Shim screw	扳手 Wrench
		h	b	L	L1	h1	f					
DCLNR/L1616H12	CN□□1204□□	16	16	100	32	16	20	MC1204	M6×21	HLD-1	M6×9P	L3.0
DCLNR/L2020K12		20	20	125	30	20	25					
DCLNR/L2525M12		25	25	150	31	25	32					
DCLNR/L3232P12		32	32	170	33	32	40					

型号 Type	刀片 Blade	规格 Specification						刀垫 Shim	销钉 Pin	压板 Clamp	螺钉 Screw	扳手 Wrench
		h	b	L	L1	h1	f					
ZCLNR/L2020K12	CN□□1204□□	20	20	125	30	20	25	MC1204	CT618-Z	HLZ-C	M8×25	L3.0 L4.0
ZCLNR/L2525M12		25	25	150	31	25	32					
ZCLNR/L3232P12		32	32	170	33	32	40					

▲更多型号可咨询，可接受高要求非标定制

MCBNR/L

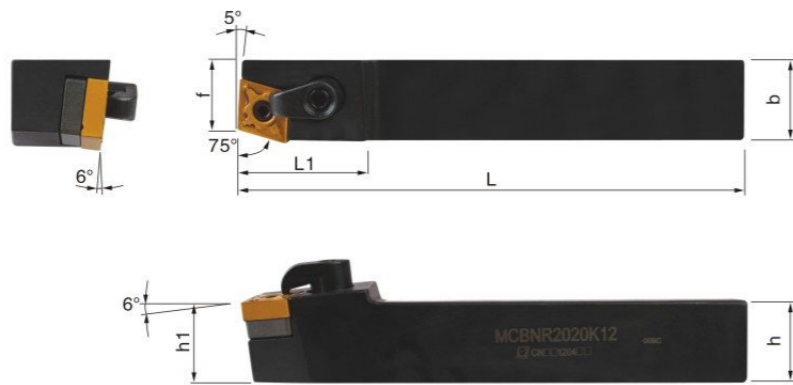
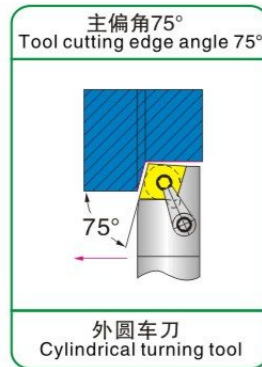

型号 Type	刀片 Blade	规格 Specification						刀垫 Shim	销钉 Pin	压板 Clamp	双头螺丝 Screw	扳手 Wrench
		h	b	L	L1	h1	f					
MCBNR/L1616H12	CN□□1204□□	16	16	100	26	16	MC1204	CTM617	HL1813	ML0625	L3.0	
MCBNR/L2020K12		20	20	125	32	20						17
MCBNR/L2525M12		25	25	150	32	25						22
MCBNR/L3232P12		32	32	170	32	32						27
MCBNR/L2525M16	CN□□1606□□	25	25	150	40	25	MC1604	CTM822	HL2217	ML0830	L3.0	
MCBNR/L3232P16		32	32	170	40	32					27	L4.0
MCBNR/L3232P19	CN□□1906□□	32	32	170	41	32	MC1904	CTM1022	HL2217	ML0830	L4.0	
MCBNR/L4040R19		40	40	200	41	40						35

型号 Type	刀片 Blade	规格 Specification						刀垫 Shim	压板螺钉 Plate screws	压板 Clamp	刀垫螺钉 Shim screw	扳手 Wrench
		h	b	L	L1	h1	f					
DCBNR/L2020K12	CN□□1204□□	20	20	125	32	20	MC1204	M6×21	HLD-1	M6×9P	L3.0	
DCBNR/L2525M12		25	25	150	32	25						22
DCBNR/L3232P12		32	32	170	32	32						27

▲更多型号可咨询，可接受高要求非标定制

MCKNR/L

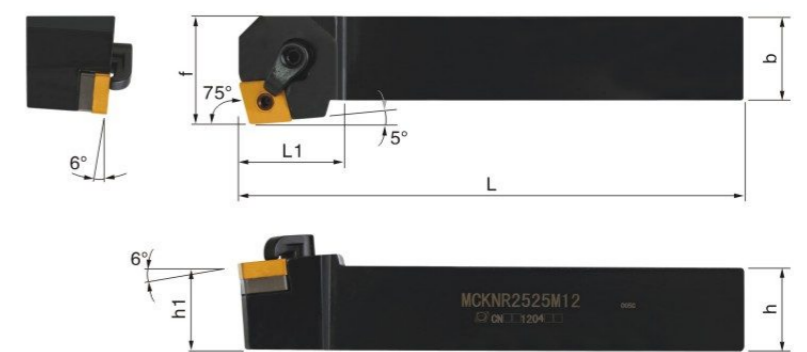
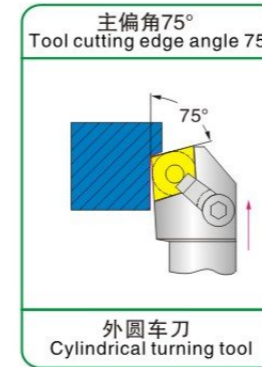

型号 Type	刀片 Blade	规格 Specification						刀垫 Shim	销钉 Pin	压板 Clamp	双头螺丝 Screw	扳手 Wrench
		h	b	L	L1	h1	f					
MCKNR/L1616H12	CN□□1204□□	16	16	100	31.5	16	MC1204	CTM617	HL1813	ML0625	L3.0	
MCKNR/L2020K12		20	20	125	31.0	20						25
MCKNR/L2525M12		25	25	150	31.0	25						32
MCKNR/L3232P12		32	32	170	31.0	32						40
MCKNR/L2525M16	CN□□1606□□	25	25	150	38	25	MC1604	CTM822	HL2217	ML0830	L3.0	
MCKNR/L3232P16		32	32	170	36	32					40	L4.0
MCKNR/L3232P19	CN□□1906□□	32	32	170	35	32	MC1904	CTM1022	HL2217	ML0830	L4	

型号 Type	刀片 Blade	规格 Specification						刀垫 Shim	压板螺钉 Plate screws	压板 Clamp	刀垫螺钉 Shim screw	扳手 Wrench
		h	b	L	L1	h1	f					
DCKNR/L1616H12	CN□□1204□□	16	16	100	31.5	16	MC1204	M6×21	HLD-1	M6×9P	L3.0	
DCKNR/L2020K12		20	20	125	31.0	20						25
DCKNR/L2525M12		25	25	150	31.0	25						32
DCKNR/L3232P12		32	32	170	31.0	32						40

型号 Type	刀片 Blade	规格 Specification						刀垫 Shim	销钉 Pin	压板 Clamp	螺钉 Screw	扳手 Wrench
		h	b	L	L1	h1	f					
ZCKNR/L2020K12	CN□□1204□□	20	20	125	31.0	20	MC1204	CT618-Z	HLZ-CB	M8×25	L3.0	
ZCKNR/L2525M12		25	25	150	31.0	25						32
ZCBNR/L3232P12		32	32	170	31.0	32						40

▲更多型号可咨询，可接受高要求非标定制

MCSNR/L

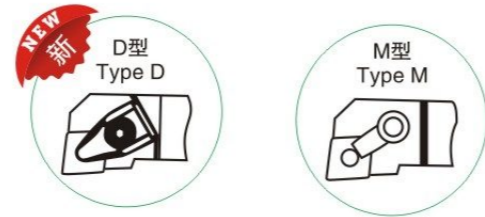
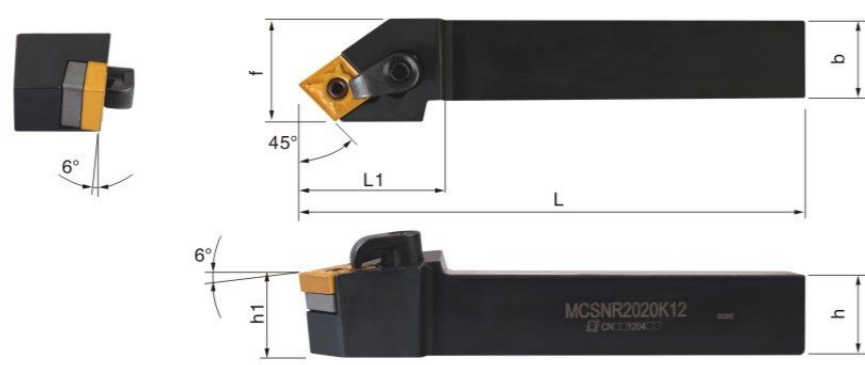
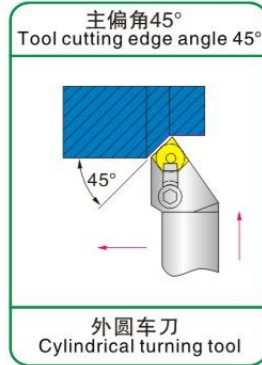

型号 Type	刀片 Blade	规格 Specification						刀垫 Shim	销钉 Pin	压板 Clamp	双头螺丝 Screw	扳手 Wrench
		h	b	L	L1	h1	f					
MCSNR/L2020K12	CN□□1204□□	20	20	125	35	20	25	MC1204	CTM617	HL1813	ML0625	L3.0
MCSNR/L2525M12		25	25	150	38	25	32					
MCSNR/L3232P12		32	32	170	38	32	40					

型号 Type	刀片 Blade	规格 Specification						刀垫 Shim	压板螺钉 Plate screws	压板 Clamp	刀垫螺钉 Shim screw	扳手 Wrench
		h	b	L	L1	h1	f					
DCSNR/L2020K12	CN□□1204□□	20	20	125	35	20	25	MC1204	M6×21	HLD-1	M6×9P	L3.0
DCSNR/L2525M12		25	25	150	38	25	32					
DCSNR/L3232P12		32	32	170	38	32	40					

▲更多型号可咨询，可接受高要求非标定制

MCGNR/L

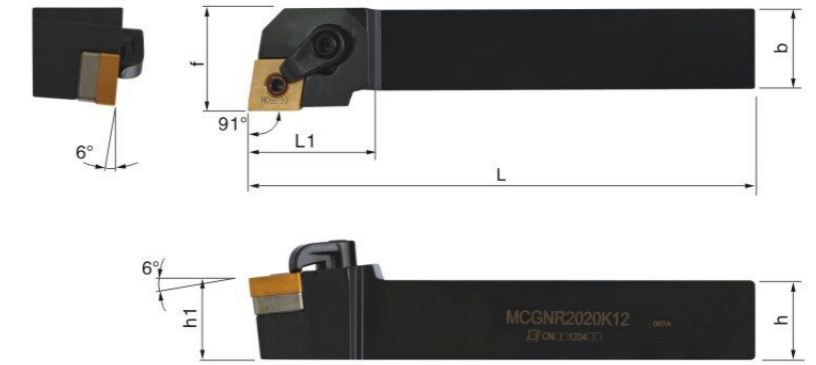
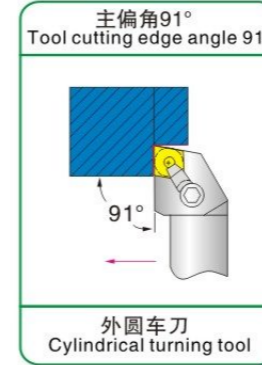

型号 Type	刀片 Blade	规格 Specification						刀垫 Shim	销钉 Pin	压板 Clamp	双头螺丝 Screw	扳手 Wrench
		h	b	L	L1	h1	f					
MCGNR/L1616H12	CN□□1204□□	16	16	100	32	16	20	MC1204	CTM617	HL1813	ML0625	L3.0
MCGNR/L2020K12		20	20	125	30	20	25					
MCGNR/L2525M12		25	25	150	32	25	32					
MCGNR/L3232P12		32	32	170	32	32	40					

型号 Type	刀片 Blade	规格 Specification						刀垫 Shim	压板螺钉 Plate screws	压板 Clamp	刀垫螺钉 Shim screw	扳手 Wrench
		h	b	L	L1	h1	f					
DCGNR/L1616H12	CN□□1204□□	16	16	100	32	16	20	MC1204	M6×21	HLD-1	M6×9P	L3.0
DCGNR/L2020K12		20	20	125	30	20	25					
DCGNR/L2525M12		25	25	150	32	25	32					
DCGNR/L3232P12		32	32	170	32	32	40					

型号 Type	刀片 Blade	规格 Specification						刀垫 Shim	销钉 Pin	压板 Clamp	螺钉 Screw	扳手 Wrench
		h	b	L	L1	h1	f					
ZCGNR/L2020K12	CN□□1204□□	20	20	125	30	20	25	MC1204	CT618-Z	HLZ-C	M8×25	L3.0 L4.0
ZCGNR/L2525M12		25	25	150	31	25	32					
ZCGNR/L3232P12		32	32	170	33	32	40					

▲更多型号可咨询，可接受高要求非标定制

MCMNN-80

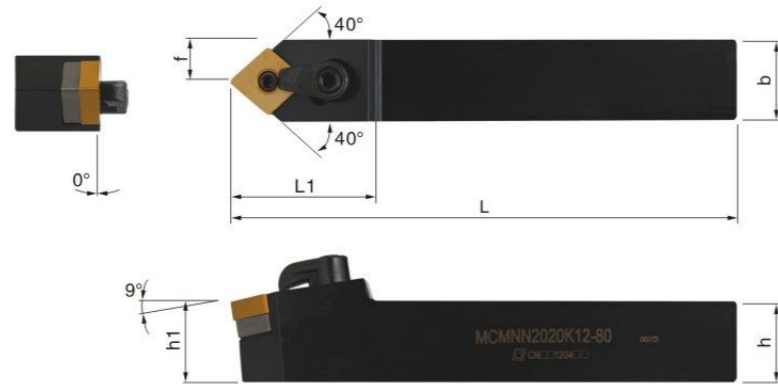
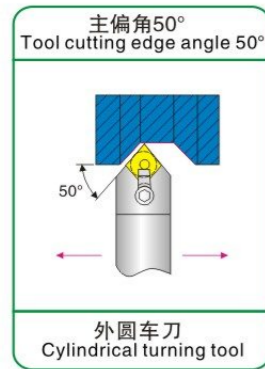

型号 Type	刀片 Blade	规格 Specification						刀垫 Shim	销钉 Pin	压板 Clamp	双头螺丝 Screw	扳手 Wrench
		h	b	L	L1	h1	f					
MCMNN1616H12-80	CN□□1204□□	16	16	100	35	16	8	MC1204	CTM617	HL1813	ML0625	L3.0
MCMNN2020K12-80		20	20	125	35	20	10					
MCMNN2525M12-80		25	25	150	38	25	12.5					
MCMNN3232P12-80		32	32	170	38	32	16					

型号 Type	刀片 Blade	规格 Specification						刀垫 Shim	压板螺钉 Plate screws	压板 Clamp	刀垫螺钉 Shim screw	扳手 Wrench
		h	b	L	L1	h1	f					
DCMNN1616H12-80	CN□□1204□□	16	16	100	35	16	8	MC1204	M6×21	HLD-1	M6×9P	L3.0
DCMNN2020K12-80		20	20	125	35	20	10					
DCMNN2525M12-80		25	25	150	38	25	12.5					
DCMNN3232P12-80		32	32	170	38	32	16					

型号 Type	刀片 Blade	规格 Specification						刀垫 Shim	销钉 Pin	压板 Clamp	螺钉 Screw	扳手 Wrench
		h	b	L	L1	h1	f					
ZCMNN2020K12-80	CN□□1204□□	20	20	125	35	20	10	MC1204	CT618-Z	HLZ-C	M8×25	L3.0 L4.0
ZCMNN2525M12-80		25	25	150	38	25	12.5					
ZCMNN3232P12-80		32	32	170	38	32	16					

▲更多型号可咨询，可接受高要求非标定制

MCMNN-100

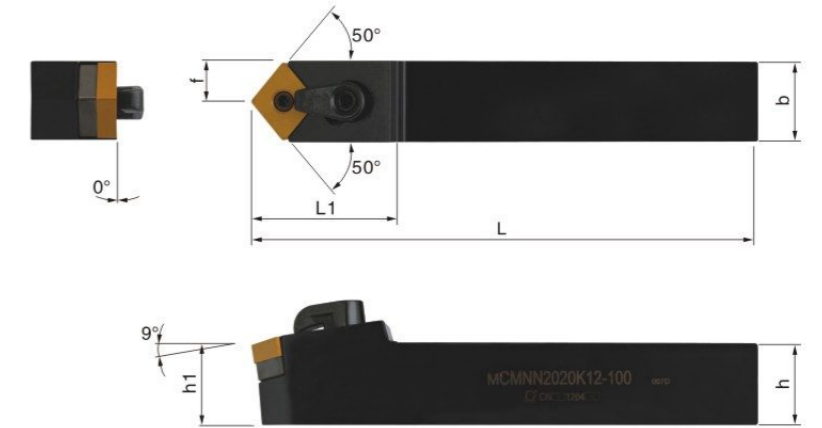
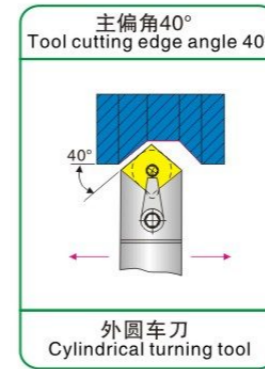

型号 Type	刀片 Blade	规格 Specification						刀垫 Shim	销钉 Pin	压板 Clamp	双头螺丝 Screw	扳手 Wrench
		h	b	L	L1	h1	f					
MCMNN2020K12-100	CN□□1204□□	20	20	125	35	20	10	MC1204	CTM617	HL1813	ML0625	L3.0
MCMNN2525M12-100		25	25	150	36	25	12.5					
MCMNN3232P12-100		32	32	170	36	32	16					

型号 Type	刀片 Blade	规格 Specification						刀垫 Shim	压板螺钉 Plate screws	压板 Clamp	刀垫螺钉 Shim screw	扳手 Wrench
		h	b	L	L1	h1	f					
DCMNN2020K12-100	CN□□1204□□	20	20	125	35	20	10	MC1204	M6×21	HLD-1	M6×9P	L3.0
DCMNN2525M12-100		25	25	150	36	25	12.5					
DCMNN3232P12-100		32	32	170	36	32	16					

型号 Type	刀片 Blade	规格 Specification						刀垫 Shim	销钉 Pin	压板 Clamp	螺钉 Screw	扳手 Wrench
		h	b	L	L1	h1	f					
ZCMNN2020K12-100	CN□□1204□□	20	20	125	35	20	10	MC1204	CT618-Z	HLZ-CB	M8×25	L3.0 L4.0
ZCMNN2525M12-100		25	25	150	36	25	12.5					
ZCMNN3232P12-100		32	32	170	36	32	16					

▲更多型号可咨询，可接受高要求非标定制

MDPNN

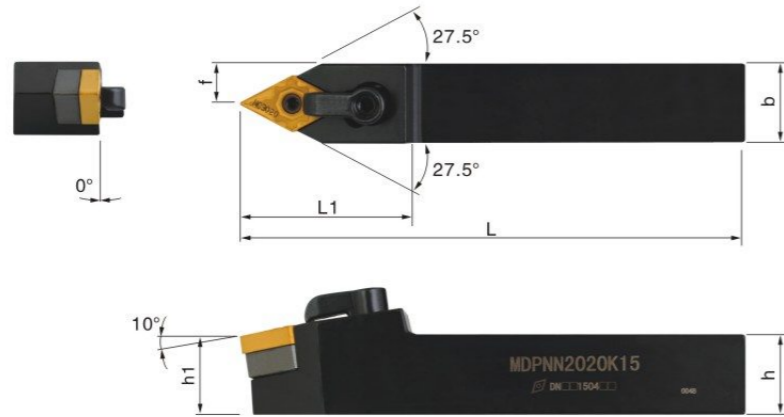
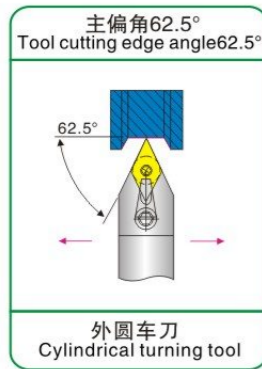

型号 Type	刀片 Blade	规格 Specification						刀垫 Shim	销钉 Pin	压板 Clamp	双头螺丝 Screw	扳手 Wrench
		h	b	L	L1	h1	f					
MDPNN1616H11	DN□□1104□□	16	16	100	36	16	8	MD1103	CTM513	HL1813	ML0625	L2.0 L3.0
MDPNN2020K11		20	20	125	36	20	10					
MDPNN2525M11		25	25	150	36	25	12.5					
MDPNN2020K15	DN□□1504□□ DN□□1506□□	20	20	125	43	20	10	MD1504 MD1506	CTM619	HL2114	ML0625	L3.0
MDPNN2525M15		25	25	150	43	25	12.5					
MDPNN3232P15		32	32	170	43	32	16					

型号 Type	刀片 Blade	规格 Specification						刀垫 Shim	压板螺钉 Plate screws	压板 Clamp	刀垫螺钉 Shim screw	扳手 Wrench
		h	b	L	L1	h1	f					
DDPNN1616H11	DN□□1104□□	16	16	100	36	16	8	MD1103	M6×21	HLD-3	M5×9P	L3.0
DDPNN2020K11		20	20	125	36	20	10					
DDPNN2525M11		25	25	150	36	25	12.5					
DDPNN2020K15	DN□□1504□□ DN□□1506□□	20	20	125	43	20	10	MD1504 MD1506	M6×21	HLD-2	M6×9P	L3.0
DDPNN2525M15		25	25	150	43	25	12.5					
DDPNN3232P15		32	32	170	43	32	16					

型号 Type	刀片 Blade	规格 Specification						刀垫 Shim	销钉 Pin	压板 Clamp	螺钉 Screw	扳手 Wrench
		h	b	L	L1	h1	f					
ZDPNN2020K15	DN□□1504□□	20	20	125	39	20	25	MD1504	CT618-Z	HLZ-D	M8×25	L3.0 L4.0
ZDPNN2525M15		25	25	150	40	25	32					
ZDPNN3232P15		32	32	170	42	32	40					

▲更多型号可咨询，可接受高要求非标定制

MDJNR/L

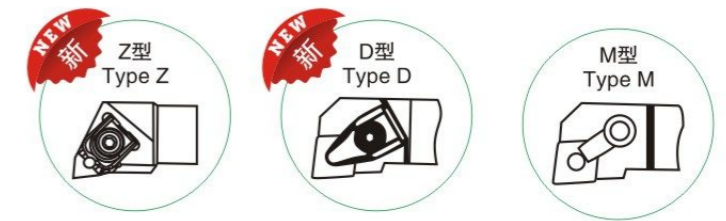
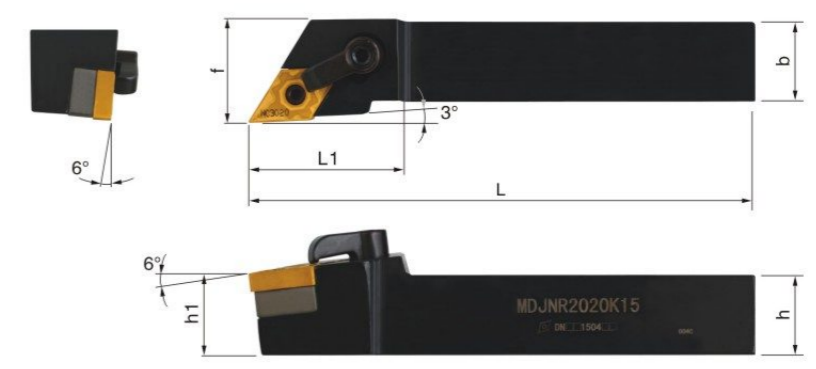
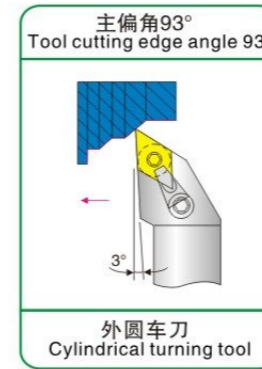

型号 Type	刀片 Blade	规格 Specification						刀垫 Shim	销钉 Pin	压板 Clamp	双头螺丝 Screw	扳手 Wrench
		h	b	L	L1	h1	f					
MDJNR/L1616H11	DN□□1104□□	16	16	100	31.5	16	20	MD1103	CTM513	HL1813	ML0625	L2.0 L3.0
MDJNR/L2020K11		20	20	125	33	20	25					
MDJNR/L2525M11		25	25	150	33	25	32					
MDJNR/L2020K15	DN□□1504□□ DN□□1506□□	20	20	125	39	20	25	MD1504 MD1506	CTM619	HL2114	ML0625	L3.0
MDJNR/L2525M15		25	25	150	40	25	32					
MDJNR/L3232P15		32	32	170	42	32	40					

型号 Type	刀片 Blade	规格 Specification						刀垫 Shim	压板螺钉 Plate screws	压板 Clamp	刀垫螺钉 Shim screw	扳手 Wrench
		h	b	L	L1	h1	f					
DDJNR/L1616H11	DN□□1104□□	16	16	100	31.5	16	20	MD1103	M6×21	HLD-3	M5×9P	L3.0
DDJNR/L2020K11		20	20	125	33	20	25					
DDJNR/L2525M11		25	25	150	33	25	32					
DDJNR/L2020K15	DN□□1504□□ DN□□1506□□	20	20	125	39	20	25	MD1504 MD1506	M6×21	HLD-2	M6×9P	L3.0
DDJNR/L2525M15		25	25	150	40	25	32					
DDJNR/L3232P15		32	32	170	42	32	40					

型号 Type	刀片 Blade	规格 Specification						刀垫 Shim	销钉 Pin	压板 Clamp	螺钉 Screw	扳手 Wrench
		h	b	L	L1	h1	f					
ZDJNR2020K15	DN□□1504□□	20	20	125	39	20	25	MD1504	CT618-Z	HLZ-D	M8×25	L3.0 L4.0
ZDJNR2525M15		25	25	150	40	25	32					
ZDJNR3232P15		32	32	170	42	32	40					

▲更多型号可咨询，可接受高要求非标定制

MDQNR/L

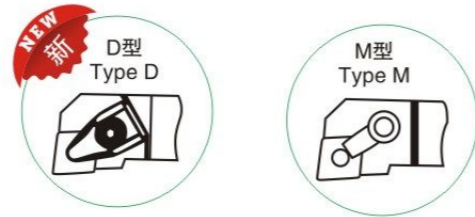
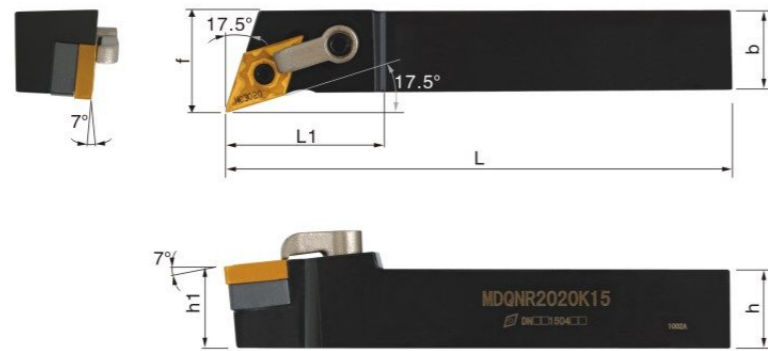
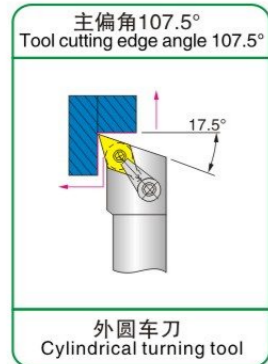

型号 Type	刀片 Blade	规格 Specification						刀垫 Shim	销钉 Pin	压板 Clamp	双头螺丝 Screw	扳手 Wrench
		h	b	L	L1	h1	f					
MDQNR/L1616H11	DN□□1104□□	16	16	100	32	16	20	MD1103	CTM513	HL1813	ML0625	L2.0 L3.0
MDQNR/L2020K11		20	20	125	30	20	25					
MDQNR/L2020K15	DN□□1504□□ DN□□1506□□	20	20	125	37	20	25	MD1506 MD1504	CTM619	HL2114	ML0625	L3.0
MDQNR/L2525M15		25	25	150	37	25	32					
MDQNR/L3232P15		32	32	170	37	32	40					

型号 Type	刀片 Blade	规格 Specification						刀垫 Shim	压板螺钉 Plate screws	压板 Clamp	刀垫螺钉 Shim screw	扳手 Wrench
		h	b	L	L1	h1	f					
DDQNR/L1616H11	DN□□1104□□	16	16	100	32	16	20	MD1103	M6×21	HLD-3	M5×9P	L3.0
DDQNR/L2020K11		20	20	125	32	20	25					
DDQNR/L2020K15	DN□□1504□□ DN□□1506□□	20	20	125	37	20	25	MD1504 MD1506	M6×21	HLD-2	M6×9P	L3.0
DDQNR/L2525M15		25	25	150	37	25	32					
DDQNR/L3232P15		32	32	170	37	32	40					

▲更多型号可咨询, 可接受高要求非标定制

MDFNR/L

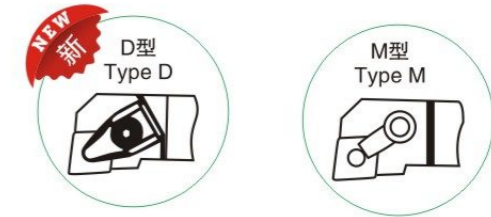
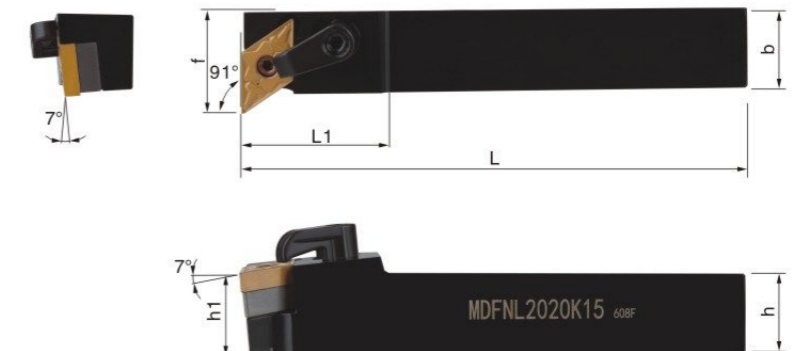
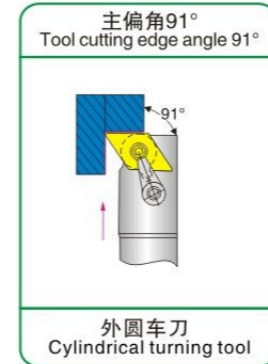

型号 Type	刀片 Blade	规格 Specification						刀垫 Shim	销钉 Pin	压板 Clamp	双头螺丝 Screw	扳手 Wrench
		h	b	L	L1	h1	f					
MDFNR/L1616H11	DN□□1104□□	16	16	100	32	16	20	MD1104	CTM513	HL1813	ML0625	L2.0 L3.0
MDFNR/L2020K11		20	20	125	32	20	20					
MDFNR/L2020K15	DN□□1504□□ DN□□1506□□	20	20	125	32	20	25	MD1506 MD1504	CTM619	HL1813	ML0625	L3.0
MDFNR/L2525M15		25	25	150	32	25	32					
MDFNR/L3232P15		32	32	170	32	32	40					

型号 Type	刀片 Blade	规格 Specification						刀垫 Shim	压板螺钉 Plate screws	压板 Clamp	刀垫螺钉 Shim screw	扳手 Wrench
		h	b	L	L1	h1	f					
DDFNR/L1616H11	DN□□1104□□	16	16	100	32	16	20	MD1103	M6×21	HLD-3	M5×9P	L3.0
DDFNR/L2020K11		16	16	100	32	16	20					
DDFNR/L2020K15	DN□□1504□□ DN□□1506□□	20	20	125	37	20	25	MD1504 MD1506	M6×21	HLD-2	M6×9P	L3.0
DDFNR/L2525M15		25	25	150	37	25	32					
DDFNR/L3232P15		32	32	170	37	32	40					

▲更多型号可咨询, 可接受高要求非标定制

MSBNR/L

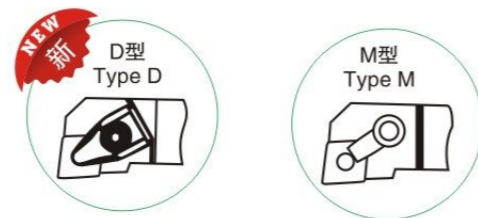
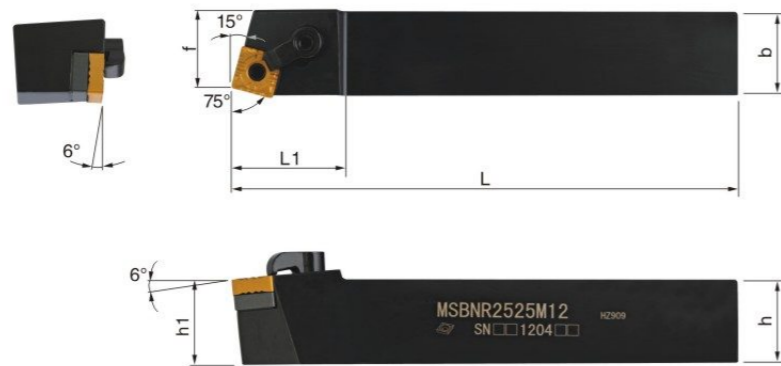
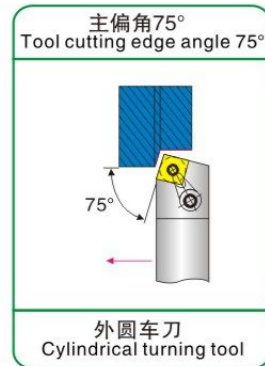

型号 Type	刀片 Blade	规格 Specification						刀垫 Shim	销钉 Pin	压板 Clamp	双头螺丝 Screw	扳手 Wrench
		h	b	L	L1	h1	f					
MSBNR/L2020K12	SN□□1204□□	20	20	125	32.5	20	17	MS1204	CTM617	HL1813	ML0625	L3.0
MSBNR/L2525M12		25	25	150	32.5	25	22					
MSBNR/L3232P12		32	32	170	32.5	32	27					
MSBNR/L2525M15	SN□□1506□□	25	25	150	35	25	32	MS1504	CTM822	HL2217	ML0830	L3.0 L4.0
MSBNR/L3232P15		32	32	170	35	32	40					
MSBNR/L3232P19	SN□□1906□□	32	32	170	35	32	27	MS1904	CTM1022	HL2217	ML0830	L4.0
MSBNR/L4040R19		40	40	200	35	40	35					

型号 Type	刀片 Blade	规格 Specification						刀垫 Shim	压板螺钉 Plate screws	压板 Clamp	刀垫螺钉 Shim screw	扳手 Wrench
		h	b	L	L1	h1	f					
DSBNR/L2020K12	SN□□1204□□	20	20	125	32.5	20	17	MS1204	M6×21	HLD-1	M6×9P	L3.0
DSBNR/L2525M12		25	25	150	32.5	25	22					
DSBNR/L3232P12		32	32	170	32.5	32	27					

▲更多型号可咨询，可接受高要求非标定制

MSDNN

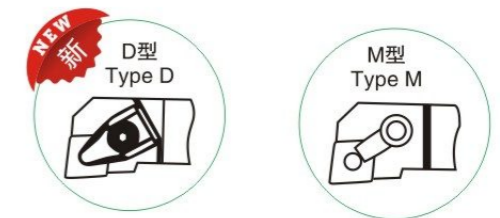
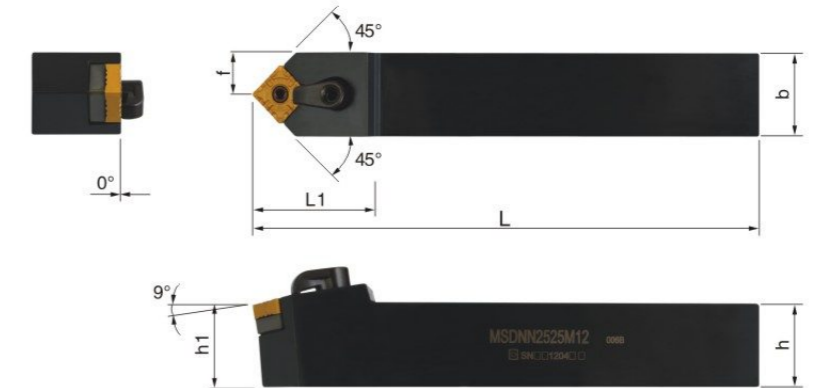
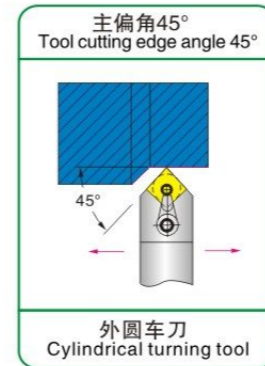

型号 Type	刀片 Blade	规格 Specification						刀垫 Shim	销钉 Pin	压板 Clamp	双头螺丝 Screw	扳手 Wrench
		h	b	L	L1	h1	f					
MSDNN1616H12	SN□□1204□□	16	16	100	35	16	8	MS1204	CTM617	HL1813	ML0625	L3.0
MSDNN2020K12		20	20	125	35	20	10					
MSDNN2525M12		25	25	150	37	25	12.5					
MSDNN3232P12		32	32	170	37	32	16					
MSDNN2525M15	SN□□1506□□	25	25	150	43	25	12.5	MS1504	CTM822	HL2217	ML0830	L3 L4
MSDNN3232P15		32	32	170	43	32	16					
MSDNN3232P19	SN□□1906□□	32	32	170	45	32	16	MS1904	CTM1022	HL2217	ML0830	L4
MSDNN4040R19		40	40	200	45	40	20					

型号 Type	刀片 Blade	规格 Specification						刀垫 Shim	压板螺钉 Plate screws	压板 Clamp	刀垫螺钉 Shim screw	扳手 Wrench
		h	b	L	L1	h1	f					
DSDNN1616H12	SN□□1204□□	16	16	100	35	16	8	MS1204	M6×21	HLD-1	M6×9P	L3.0
DSDNN2020K12		20	20	125	35	20	10					
DSDNN2525M12		25	25	150	37	25	12.5					
DSDNN3232P12		32	32	170	37	32	16					

▲更多型号可咨询，可接受高要求非标定制

MSKNR/L

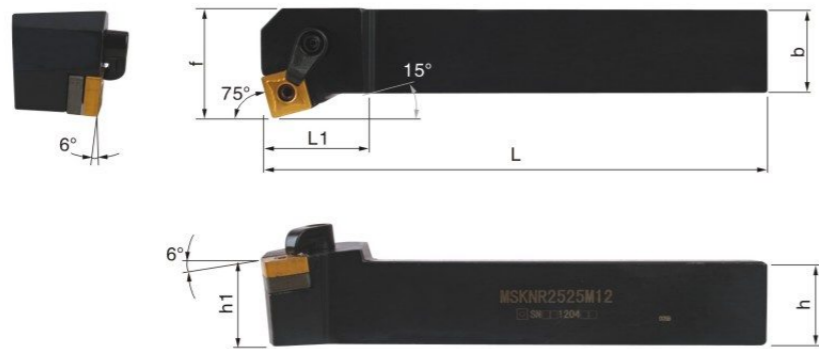
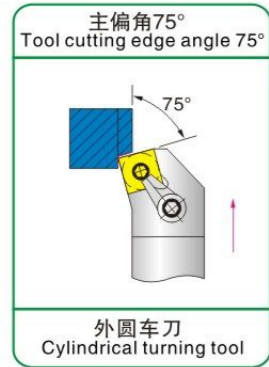

型号 Type	刀片 Blade	规格 Specification						刀垫 Shim	销钉 Pin	压板 Clamp	双头螺丝 Screw	扳手 Wrench
		h	b	L	L1	h1	f					
MSKNR/L2020K12		20	20	125	31	20	25	MS1204	CTM617	HL1813	ML0625	L3.0
MSKNR/L2525M12	SN□□1204□□	25	25	150	28	25	32					
MSKNR/L3232P12		32	32	170	28	32	40					

型号 Type	刀片 Blade	规格 Specification						刀垫 Shim	压板螺钉 Plate screws	压板 Clamp	刀垫螺钉 Shim screw	扳手 Wrench
		h	b	L	L1	h1	f					
DSKNR/L2020K12		20	20	125	31	20	25	MS1204	M6×21	HLD-1	M6×9P	L3.0
DSKNR/L2525M12	SN□□1204□□	25	25	150	28	25	32					
DSKNR/L3232P12		32	32	170	28	32	40					

▲更多型号可咨询，可接受高要求非标定制

MSRNR/L

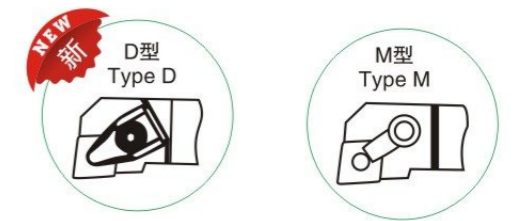
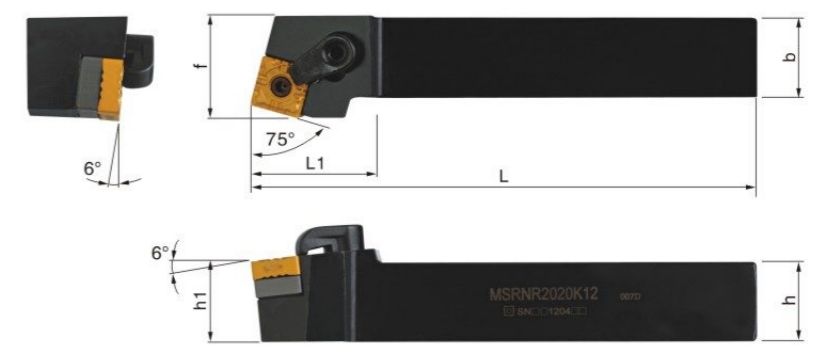
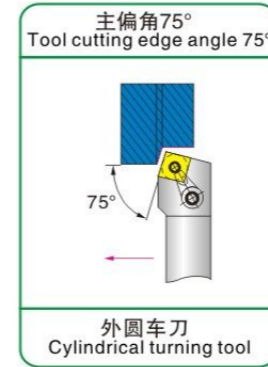

型号 Type	刀片 Blade	规格 Specification						刀垫 Shim	销钉 Pin	压板 Clamp	双头螺丝 Screw	扳手 Wrench
		h	b	L	L1	h1	f					
MSRNR/L2020K12		20	20	125	32	20	25	MS1204	CTM617	HL1813	ML0625	L3.0
MSRNR/L2525M12	SN□□1204□□	25	25	150	32	25	32					
MSRNR/L3232P12		32	32	170	32	32	40					

型号 Type	刀片 Blade	规格 Specification						刀垫 Shim	压板螺钉 Plate screws	压板 Clamp	刀垫螺钉 Shim screw	扳手 Wrench
		h	b	L	L1	h1	f					
DSRNR/L2020K12		20	20	125	32	20	25	MS1204	M6×21	HLD-1	M6×9P	L3.0
DSRNR/L2525M12	SN□□1204□□	25	25	150	32	25	32					
DSRNR/L3232P12		32	32	170	32	32	40					

▲更多型号可咨询，可接受高要求非标定制

MSSNR/L

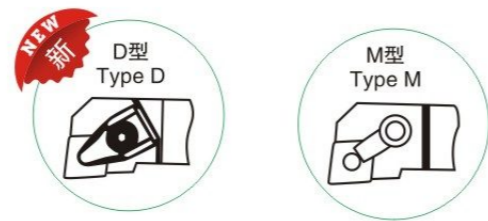
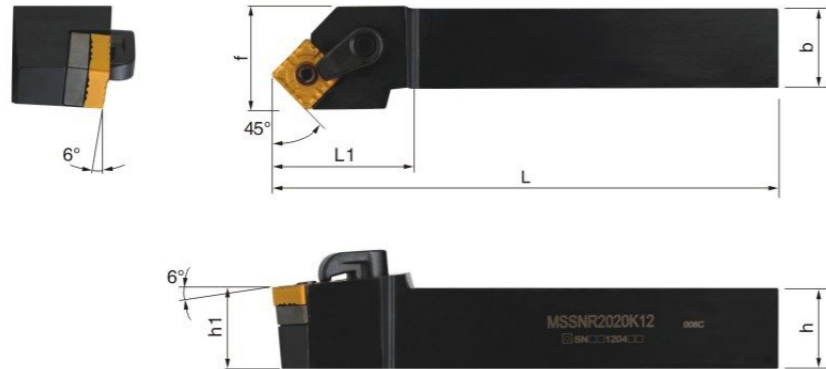
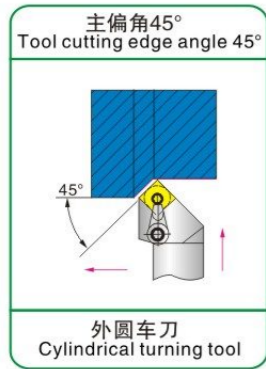

型号 Type	刀片 Blade	规格 Specification						刀垫 Shim	销钉 Pin	压板 Clamp	双头螺丝 Screw	扳手 Wrench
		h	b	L	L1	h1	f					
MSSNR/L1616H12	SN□□1204□□	16	16	100	35	16	20	MS1204	CTM617	HL1813	ML0625	L3.0
MSSNR/L2020K12		20	20	125	35	20	25					
MSSNR/L2525M12		25	25	150	37	25	32					
MSSNR/L3232P12		32	32	170	37	32	40					
MSSNR/L2525M15	SN□□1506□□	25	25	150	39	25	32	MS1504	CTM822	HL2217	ML0830	L3 L4
MSSNR/L3232P15		32	32	170	39	32	40					
MSSNR/L3232P19	SN□□1906□□	32	32	170	43	32	40	MS1904	CTM1022	HL2217	ML0830	L4
MSSNR/L4040R19		40	40	200	43	40	50					

型号 Type	刀片 Blade	规格 Specification						刀垫 Shim	压板螺钉 Plate screws	压板 Clamp	刀垫螺钉 Shim screw	扳手 Wrench
		h	b	L	L1	h1	f					
DSSNR/L1616H12	SN□□1204□□	16	16	100	35	16	20	MS1204	M6×21	HLD-1	M6×9P	L3.0
DSSNR/L2020K12		20	20	125	35	20	25					
DSSNR/L2525M12		25	25	150	37	25	32					
DSSNR/L3232P12		32	32	170	37	32	40					

▲更多型号可咨询，可接受高要求非标定制

MTQNR/L

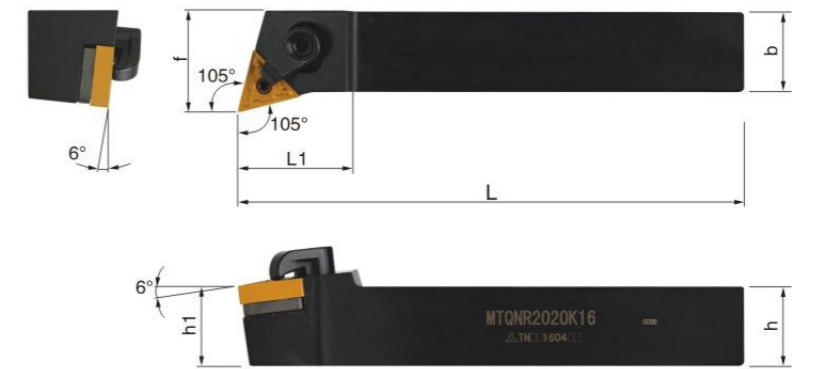
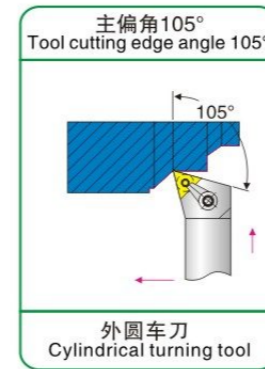

型号 Type	刀片 Blade	规格 Specification						刀垫 Shim	销钉 Pin	压板 Clamp	双头螺丝 Screw	扳手 Wrench
		h	b	L	L1	h1	f					
MTQNR/L1616H16	TN□□1604□□	16	16	100	30	16	20	MT1603	CTM513	HL1813	ML0625	L2.0 L3.0
MTQNR/L2020K16		20	20	125	28	20	25					
MTQNR/L2525M16		25	25	150	30	25	32					
MTQNR/L3232P16		32	32	170	30	32	40					

型号 Type	刀片 Blade	规格 Specification						刀垫 Shim	中心销 Center pin	压板 Clamp	双头螺丝 Screw	扳手 Wrench
		h	b	L	L1	h1	f					
WTQNR/L2020K16	TN□□1604□□	20	20	125	32	20	25	MT1603	CT515-T	HLT-16	M5×23	L2.5 L4.0
WTQNR/L2525M16		25	25	150	32	25	32					
WTQNR/L3232P16		32	32	170	32	32	40					

▲更多型号可咨询，可接受高要求非标定制

MTFNR/L

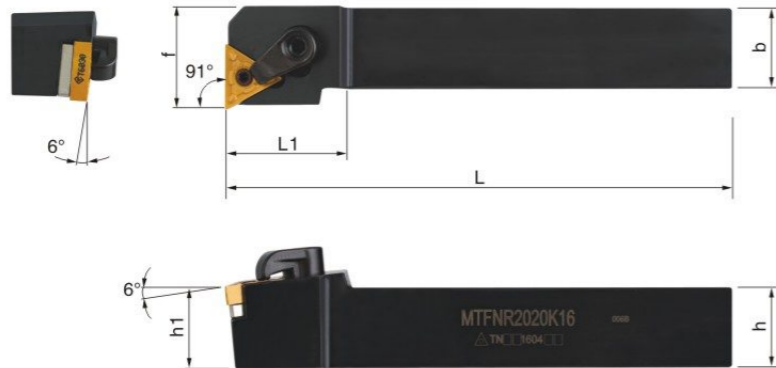
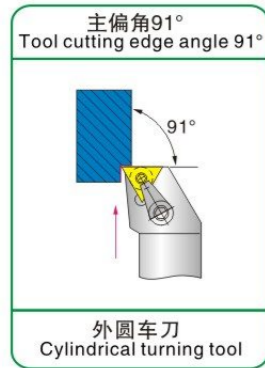

型号 Type	刀片 Blade	规格 Specification						刀垫 Shim	销钉 Pin	压板 Clamp	双头螺丝 Screw	扳手 Wrench
		h	b	L	L1	h1	f					
MTFNR/L1616H16	TN□□1604□□	16	16	100	29	16	20	MT1603	CTM513	HL1813	ML0625	L2.0 L3.0
MTFNR/L2020K16		20	20	125	29	20	25					
MTFNR/L2525M16		25	25	150	31	25	32					
MTFNR/L3232P16		32	32	170	31	32	40					
MTFNR/L2525M22	TN□□2204□□	25	25	150	36	25	32	MT2204	CTM617	HL1917	ML0830	L3.0 L4.0
MTFNR/L3232P22		32	32	170	36	32	40					

型号 Type	刀片 Blade	规格 Specification						刀垫 Shim	压板螺钉 Plate screws	压板 Clamp	刀垫螺钉 Shim screw	扳手 Wrench
		h	b	L	L1	h1	f					
DTFNR/L1616H16	TN□□1604□□	16	16	100	29	16	20	MT1603	M6×21	HLD-3	M5×9P	L3.0
DTFNR/L2020K16		20	20	125	29	20	25					
DTFNR/L2525M16		25	25	150	31	25	32					
DTFNR/L3232P16		32	32	170	31	32	40					

▲更多型号可咨询，可接受高要求非标定制

MTGNR/L

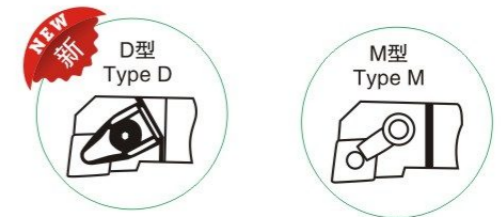
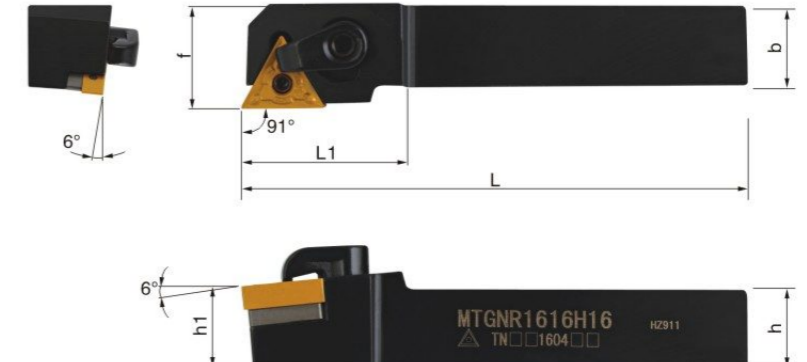
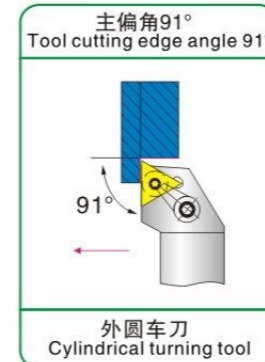

型号 Type	刀片 Blade	规格 Specification						刀垫 Shim	销钉 Pin	压板 Clamp	双头螺丝 Screw	扳手 Wrench
		h	b	L	L1	h1	f					
MTGNR/L1616H16	TN□□1604□□	16	16	100	29	16	20	MT1603	CTM513	HL1813	ML0625	L2.0 L3.0
MTGNR/L2020K16		20	20	125	29	20	25					
MTGNR/L2525M16		25	25	150	30	25	32					
MTGNR/L3232P22		32	32	170	32	32	40					

型号 Type	刀片 Blade	规格 Specification						刀垫 Shim	压板螺钉 Plate screws	压板 Clamp	刀垫螺钉 Shim screw	扳手 Wrench
		h	b	L	L1	h1	f					
DTGNR/L1616H16	TN□□1604□□	16	16	100	29	16	20	MT1603	M6×21	HLD-3	M5×9P	L3.0
DTGNR/L2020K16		20	20	125	29	20	25					
DTGNR/L2525M16		25	25	150	30	25	32					
DTGNR/L3232P22		32	32	170	32	32	40					

▲更多型号可咨询，可接受高要求非标定制

MTBNR/L

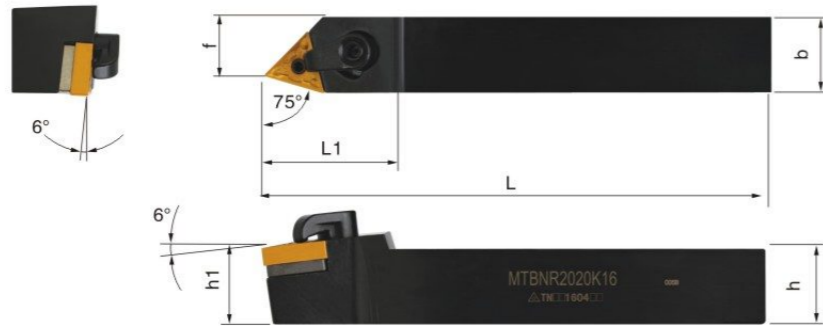
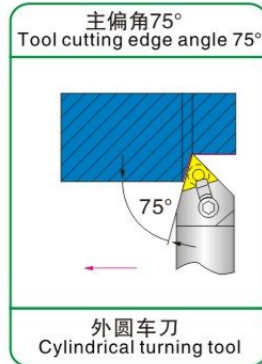

型号 Type	刀片 Blade	规格 Specification						刀垫 Shim	销钉 Pin	压板 Clamp	双头螺丝 Screw	扳手 Wrench
		h	b	L	L1	h1	f					
MTBNR/L1616H16	TN□□1604□□	20	20	125	35	20	12	MT1603	CTM513	HL1813	ML0625	L2.0 L3.0
MTBNR/L2020K16		25	25	150	35	25	15.5					

型号 Type	刀片 Blade	规格 Specification						刀垫 Shim	销钉 Pin	压板 Clamp	双头螺丝 Screw	扳手 Wrench
		h	b	L	L1	h1	f					
WTBNR/L2020K16	TN□□1604□□	20	20	125	32	20	15.5	MT1603	CT515-T	HLT-16	M5 x 23	L2.5 L4.0
WTBNR/L2525M16		25	25	150	32	25	20.5					
WTBNR/L3232P16		32	32	170	32	32	27.5					

▲更多型号可咨询, 可接受高要求非标定制

MTJNR/L

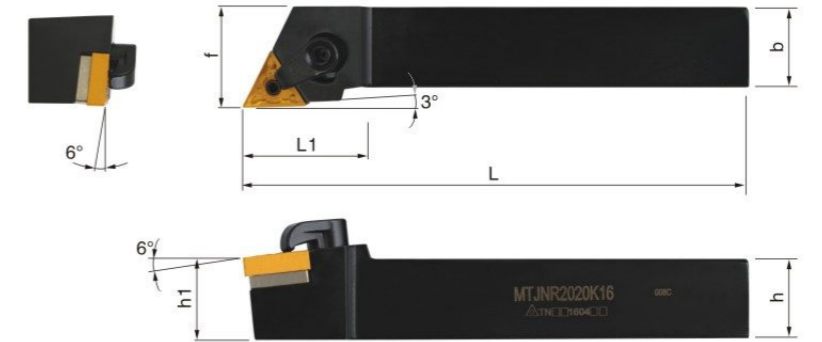
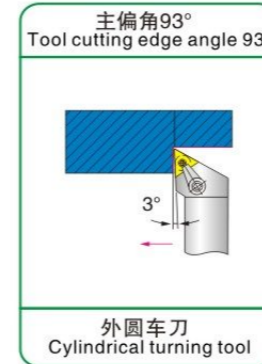

型号 Type	刀片 Blade	规格 Specification						刀垫 Shim	销钉 Pin	压板 Clamp	双头螺丝 Screw	扳手 Wrench
		h	b	L	L1	h1	f					
MTJNR/L1616H16	TN□□1604□□	16	16	100	30	16	20	MT1603	CTM513	HL1813	ML0625	L2.0 L3.0
MTJNR/L2020K16		20	20	125	32	20	25					
MTJNR/L2525M16		25	25	150	34	25	32					
MTJNR/L3232P16		32	32	170	36	32	40					
MTJNR/L2020K22	TN□□2204□□	20	20	125	37	20	25	MT2204	CTM617	HL1917	ML0830	L3.0 L4.0
MTJNR/L2525M22		25	25	150	38	25	32					
MTJNR/L3232P22		32	32	170	40	32	40					

型号 Type	刀片 Blade	规格 Specification						刀垫 Shim	销钉 Pin	压板 Clamp	双头螺丝 Screw	扳手 Wrench
		h	b	L	L1	h1	f					
WTJNR/L1616H16	TN□□1604□□	16	16	100	32	16	22	MT1603	CT515-T	HLT-16	M5 x 23	L2.5 L4.0
WTJNR/L2020K16		20	20	125	32	20	25					
WTJNR/L2525M16		25	25	150	34	25	32					
WTJNR/L3232P16		32	32	170	34	32	40					

型号 Type	刀片 Blade	规格 Specification						刀垫 Shim	销钉 Pin	压板 Clamp	双头螺丝 Screw	扳手 Wrench
		h	b	L	L1	h1	f					
MTLNR/L1616H16	TN□□1604□□	16	16	100	32	16	20	MT1603	CT513	HL1813	ML0625	L2.0 L3.0
MTLNR/L2020K16		20	20	125	32	20	25					
MTLNR/L2525M16		25	25	150	34	25	32					

▲更多型号可咨询, 可接受高要求非标定制

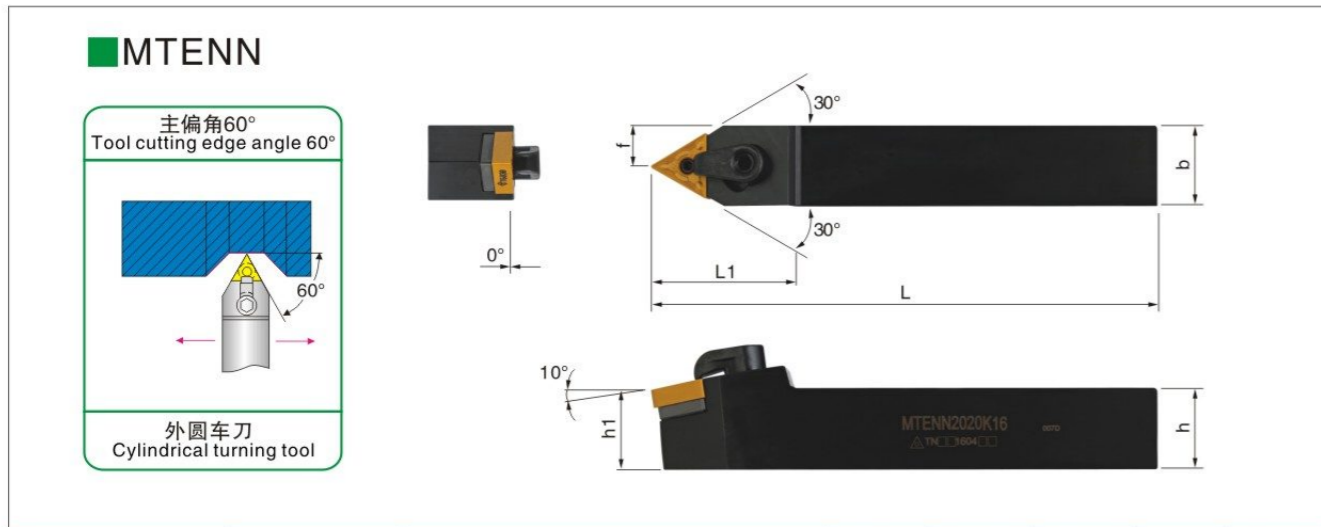

型号 Type	刀片 Blade	规格 Specification						刀垫 Shim	销钉 Pin	压板 Clamp	双头螺丝 Screw	扳手 Wrench
		h	b	L	L1	h1	f					
MTENN2020K16	TN□□1604□□	20	20	125	35	20	10	MT1603	CTM513	HL1813	ML0625	L2.0 L3.0
MTENN2525M16		25	25	150	35	25	12.5					
MTENN3232P16		32	32	170	35	32	16					
MTENN4040R16		40	40	200	35	40	20					
MTENN2525M22	TN□□2204□□	25	25	150	38	25	12.5	MT2204	CTM617	HL1917	ML0830	L3.0 L4.0
MTENN3232P22		32	32	170	38	32	16					

型号 Type	刀片 Blade	规格 Specification						刀垫 Shim	销钉 Pin	压板 Clamp	双头螺丝 Screw	扳手 Wrench
		h	b	L	L1	h1	f					
WTENN2020K16	TN□□1604□□	20	20	125	36	20	10	MT1603	CT515-T	HLT-16	M5 x 23	L2.5 L4.0
WTENN2525M16		25	25	150	36	25	12.5					
WTENN3232P16		32	32	170	36	32	16					

▲更多型号可咨询, 可接受高要求非标定制

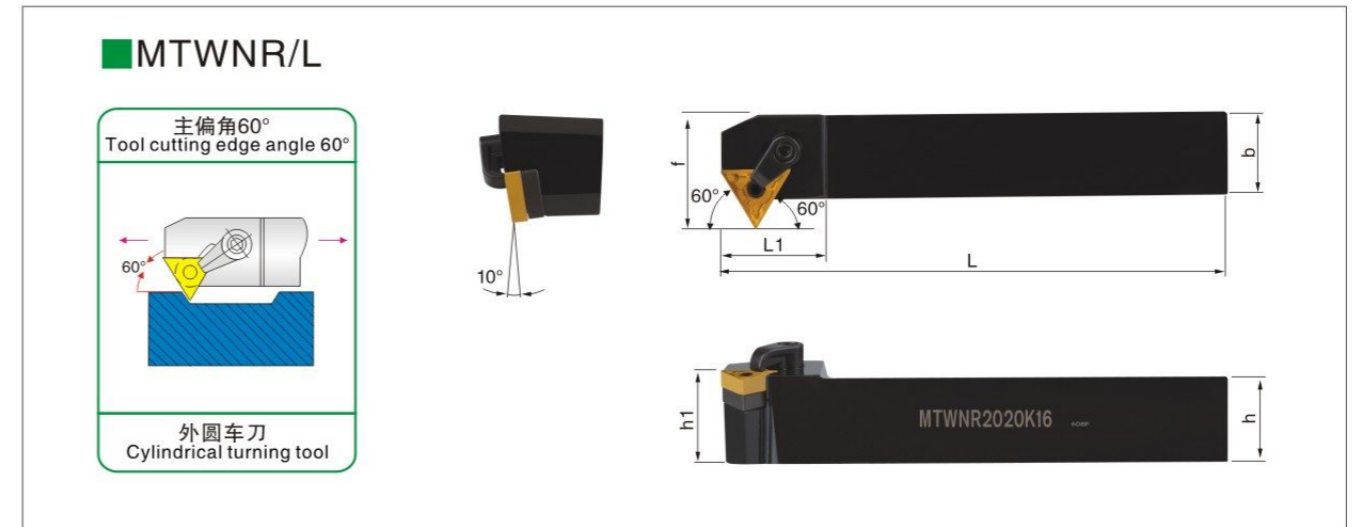

型号 Type	刀片 Blade	规格 Specification						刀垫 Shim	销钉 Pin	压板 Clamp	双头螺丝 Screw	扳手 Wrench
		h	b	L	L1	h1	f					
MTWNR/L1616H16	TN□□1604□□	16	16	100	30	16	20	MT1603	CTM513	HL1813	ML0625	L2.0 L3.0
MTWNR/L2020K16		20	20	125	30	20	25					
MTWNR/L2525M16		25	25	150	30	25	32					

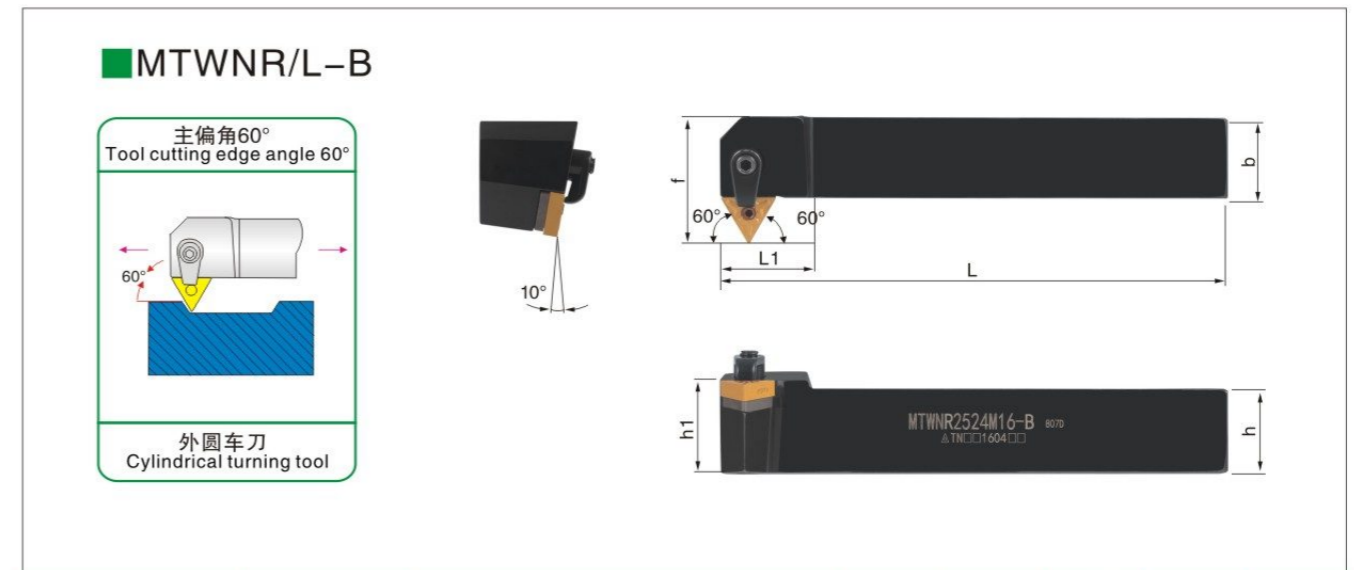

型号 Type	刀片 Blade	规格 Specification						刀垫 Shim	销钉 Pin	压板 Clamp	双头螺丝 Screw	扳手 Wrench
		h	b	L	L1	h1	f					
MTWNR/L2020K16-B	TN□□1604□□	20	20	125	26	20	33.5	MT1603	CTM513	HL1813	ML0625	L2.0 L3.0
MTWNR/L2524M16-B		25	24	150	26	25	37.5					

▲更多型号可咨询, 可接受高要求非标定制

MVJNR/L

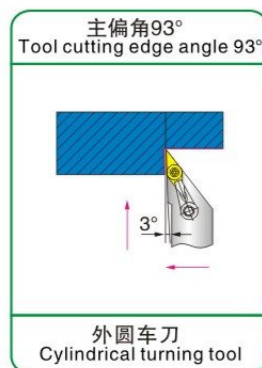

型号 Type	刀片 Blade	规格 Specification						刀垫 Shim	销钉 Pin	压板 Clamp	双头螺丝 Screw	扳手 Wrench
MVJNR/L1616K16	VN□□1604□□	h	b	L	L1	h1	f	MV1603	CTM513	HL2414	ML0625	L2.0 L3.0
MVJNR/L2020K16		16	16	125	48	16	20					
MVJNR/L2525M16		20	20	125	48	20	25					
MVJNR/L3232P16		25	25	150	48	25	32					
		32	32	170	48	32	40					

型号 Type	刀片 Blade	规格 Specification						刀垫 Shim	压板螺钉 Plate screws	压板 Clamp	刀垫螺钉 Shim screw	扳手 Wrench
DVJNR/L1616K16	VN□□1604□□	h	b	L	L1	h1	f	MV1603	M6×21	HLD-4	M5×9P	L3.0
DVJNR/L2020K16		16	16	125	48	16	20					
DVJNR/L2525M16		20	20	125	48	20	25					
DVJNR/L3232P16		25	25	150	48	25	32					
		32	32	170	48	32	40					

型号 Type	刀片 Blade	规格 Specification						刀垫 Shim	销钉 Pin	压板 Clamp	螺钉 Screw	扳手 Wrench
ZVJNR/L2020K16	VN□□1604□□	h	b	L	L1	h1	f	MV1603	CT515-Z	HLZ-V	M8×25	L2.5 L4.0
ZVJNR/L2525M16		20	20	125	48	20	25					
ZVJNR/L3232P16		25	25	150	48	25	32					
		32	32	170	48	32	40					

▲更多型号可咨询，可接受高要求非标定制

MVQNR/L

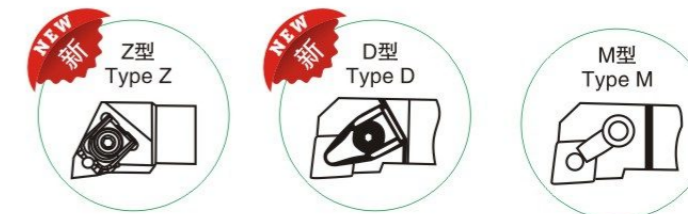
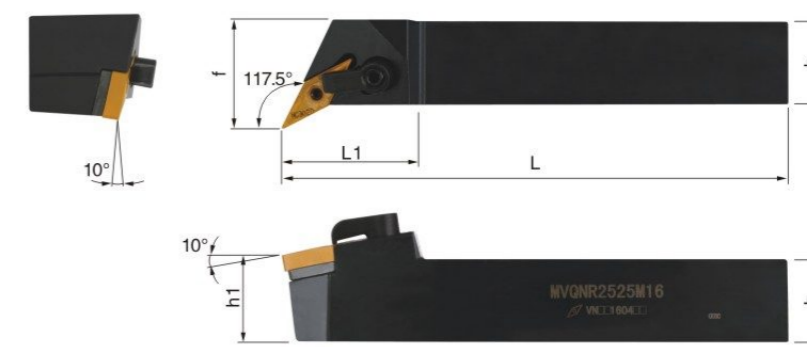
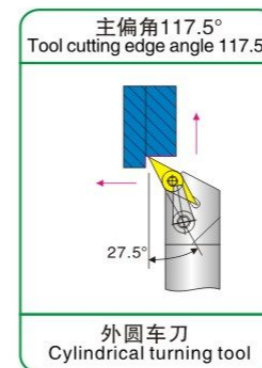

型号 Type	刀片 Blade	规格 Specification						刀垫 Shim	销钉 Pin	压板 Clamp	双头螺丝 Screw	扳手 Wrench
MVQNR/L1616K16	VN□□1604□□	h	b	L	L1	h1	f	MV1603	CTM513	HL2114	ML0625	L2.0 L3.0
MVQNR/L2020K16		16	16	125	40	16	24					
MVQNR/L2525M16		20	20	125	40	20	25					
MVQNR/L3232P16		25	25	150	40	25	32					
		32	32	170	40	32	40					

型号 Type	刀片 Blade	规格 Specification						刀垫 Shim	压板螺钉 Plate screws	压板 Clamp	刀垫螺钉 Shim screw	扳手 Wrench
DVQNR/L2020K16	VN□□1604□□	h	b	L	L1	h1	f	MV1603	M6×21	HLD-3	M5×9P	L3.0
DVQNR/L2525M16		20	20	125	40	20	25					
DVQNR/L3232P16		25	25	150	40	25	32					
		32	32	170	40	32	40					

型号 Type	刀片 Blade	规格 Specification						刀垫 Shim	销钉 Pin	压板 Clamp	螺钉 Screw	扳手 Wrench
ZVQNR/L2020K16	VN□□1604□□	h	b	L	L1	h1	f	MV1603	CT515-Z	HLZ-V	M8×25	L2.5 L4.0
ZVQNR/L2525M16		20	20	125	40	20	25					
ZVQNR/L3232P16		25	25	150	40	25	32					
		32	32	170	40	32	40					

▲更多型号可咨询，可接受高要求非标定制

MVUNR/L

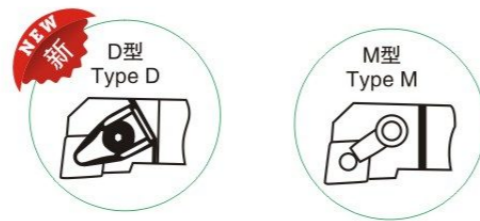
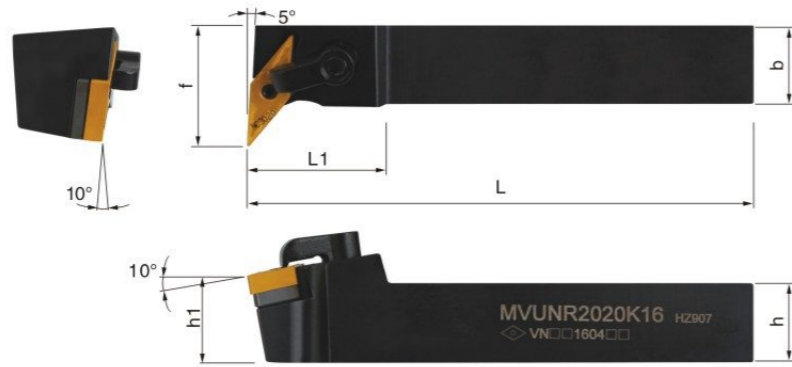
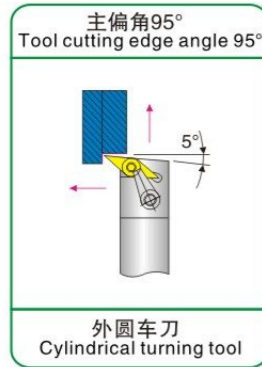

型号 Type	刀片 Blade	规格 Specification						刀垫 Shim	销钉 Pin	压板 Clamp	双头螺丝 Screw	扳手 Wrench
MVUNR/L2020K16	VN□□1604□□	h	b	L	L1	h1	f	MV1603	CTM513	HL2114	ML0625	L2.0 L3.0
MVUNR/L2525M16		20	20	125	35	20	30					

型号 Type	刀片 Blade	规格 Specification						刀垫 Shim	压板螺钉 Plate screws	压板 Clamp	刀垫螺钉 Shim screw	扳手 Wrench
DVUNR/L2020K16	VN□□1604□□	h	b	L	L1	h1	f	MV1603	M6×21	HLD-3	M5×9P	L3.0
DVUNR/L2525M16		20	20	125	35	20	30					

▲更多型号可咨询，可接受高要求非标定制

MVVNN

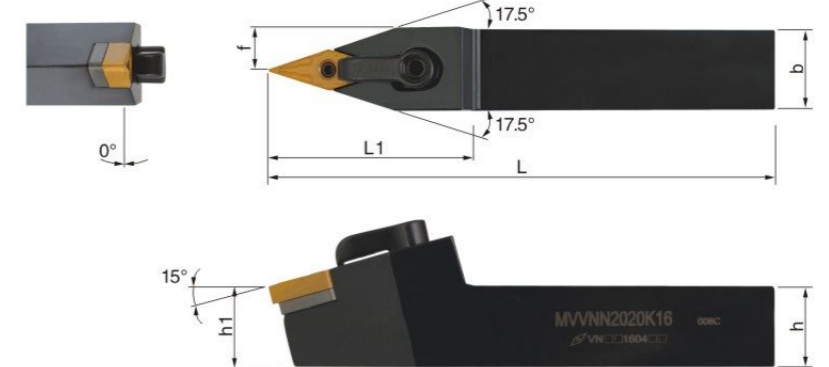
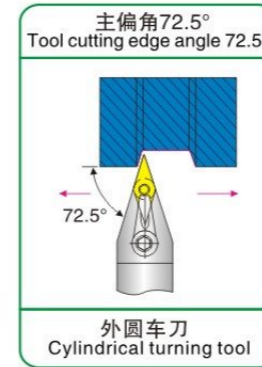

型号 Type	刀片 Blade	规格 Specification						刀垫 Shim	销钉 Pin	压板 Clamp	双头螺丝 Screw	扳手 Wrench						
MVVNN1616K16	VN□□1604□□	h	b	L	L1	h1	f	MV1603	CTM513	HL2414	ML0630	L2.0 L3.0						
MVVNN2020K16		16	16	125	48	16	8						20	20	125	48	20	10
MVVNN2525M16		25	25	150	48	25	12.5						32	32	170	48	32	20
MVVNN3232P16		20	20	125	48	20	10											

型号 Type	刀片 Blade	规格 Specification						刀垫 Shim	压板螺钉 Plate screws	压板 Clamp	刀垫螺钉 Shim screw	扳手 Wrench						
DVVNN1616K16	VN□□1604□□	h	b	L	L1	h1	f	MV1603	M6×21	HLD-3	M5×9P	L3.0						
DVVNN2020K16		16	16	125	48	16	8						20	20	125	48	20	10
DVVNN2525M16		25	25	150	48	25	12.5						32	32	170	48	32	20
DVVNN3232P16		20	20	125	48	20	10											

型号 Type	刀片 Blade	规格 Specification						刀垫 Shim	销钉 Pin	压板 Clamp	螺钉 Screw	扳手 Wrench						
ZVVNN2020K16	VN□□1604□□	h	b	L	L1	h1	f	MV1603	CT515-Z	HLZ-V	M8×25	L2.5 L4.0						
ZVVNN2525M16		20	20	125	48	20	10						25	25	150	48	25	12.5
ZVVNN3232P16		32	32	170	48	32	20											

▲更多型号可咨询，可接受高要求非标定制

MWLNRL

主偏角95°
Tool cutting edge angle 95°

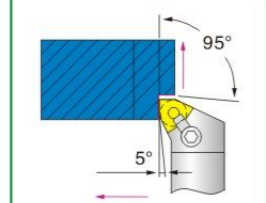

外圆车刀
Cylindrical turning tool

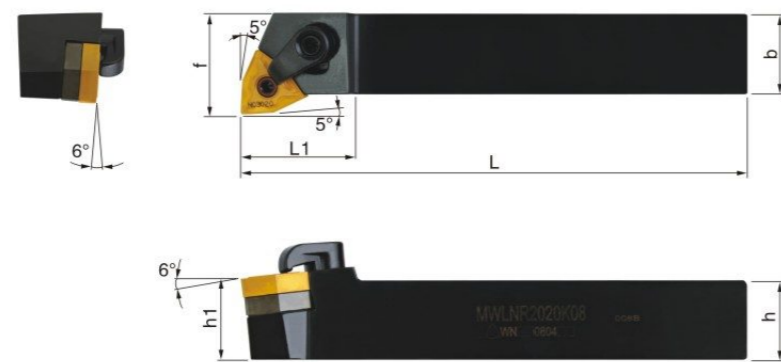

型号 Type	刀片 Blade	规格 Specification						刀垫 Shim	销钉 Pin	压板 Clamp	双头螺丝 Screw	扳手 Wrench
		h	b	L	L1	h1	f					
MWLNRL/L1616H06	WN□□0604□□	16	16	100	28	16	20	MW0603	CTM513	HL1813	ML0625	L2.0 L3.0
MWLNRL/L2020K06		20	20	125	26.0	20	25					
MWLNRL/L2525M06		25	25	150	32.0	25	32					
MWLNRL/L3232P06		32	32	170	40.0	32	40					
MWLNRL/L1616H08	WN□□0804□□	16	16	100	31	16	20	MW0804	CTM617	HL1813	ML0625	L3.0
MWLNRL/L2020K08		20	20	125	28.0	20	25					
MWLNRL/L2525M08		25	25	150	32.0	25	32					
MWLNRL/L3232P08		32	32	170	32.0	32	40					

型号 Type	刀片 Blade	规格 Specification						刀垫 Shim	压板螺钉 Plate screws	压板 Clamp	刀垫螺钉 Shim screw	扳手 Wrench
		h	b	L	L1	h1	f					
DWLNRL/L1616H06	WN□□0604□□	16	16	100	28	16	20	MW0603	M6×21	HLD-3	M5×9P	L3.0
DWLNRL/L2020K06		20	20	125	26.0	20	25					
DWLNRL/L2525M06		25	25	150	32.0	25	32					
DWLNRL/L3232P06		32	32	170	40.0	32	40					
DWLNRL/L1616H08	WN□□0804□□	16	16	100	31	16	20	MW0804	HLD-1	M6×9P	L3.0	
DWLNRL/L2020K08		20	20	125	28.0	20	25					
DWLNRL/L2525M08		25	25	150	32.0	25	32					
DWLNRL/L3232P08		32	32	170	32.0	32	40					

型号 Type	刀片 Blade	规格 Specification						刀垫 Shim	销钉 Pin	楔块压紧 Clamp	压紧螺钉 Screw	扳手 Wrench
		h	b	L	L1	h1	f					
ZWLNRL/L1616H08	WN□□0804□□	16	16	100	38	10	25	MW0408	CT618-Z	HLZ-08	M8×25	L3.0 L4.0
ZWLNRL/L2020K08		20	20	125	38	20	25					
ZWLNRL/L2525M08		25	25	150	38	25	32					
ZWLNRL/L3232P08		32	32	170	38	32	40					

▲更多型号可咨询，可接受高要求非标定制

MWENN

主偏角50°
Tool cutting edge angle 50°

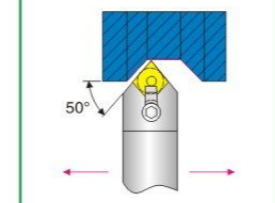

外圆车刀
Cylindrical turning tool

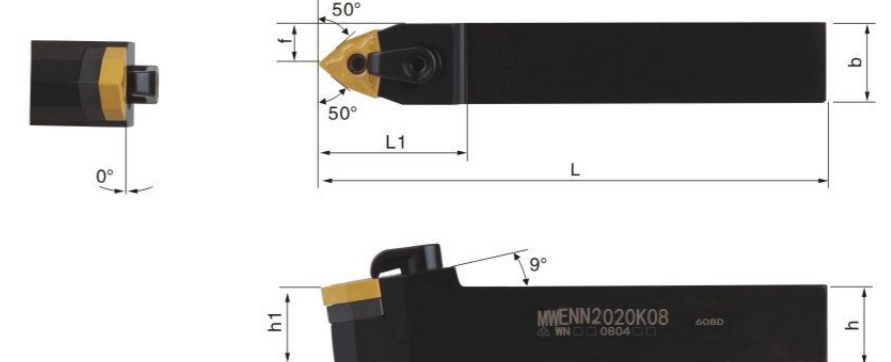

型号 Type	刀片 Blade	规格 Specification						刀垫 Shim	销钉 Pin	压板 Clamp	双头螺丝 Screw	扳手 Wrench
		h	b	L	L1	h1	f					
MWENN1616H08	WN□□0804□□	16	16	100	32	16	8	MW0804	CTM617	HL1813	ML0625	L3.0
MWENN2020K08		20	20	125	32	20	10					
MWENN2525M08		25	25	150	32	25	12.5					

▲更多型号可咨询，可接受高要求非标定制

MWWNRL

主偏角50°
Tool cutting edge angle 50°

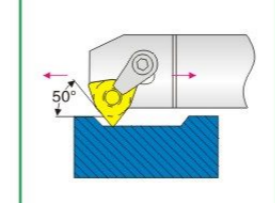

外圆车刀
Cylindrical turning tool



型号 Type	刀片 Blade	规格 Specification						刀垫 Shim	销钉 Pin	压板 Clamp	双头螺丝 Screw	扳手 Wrench
		h	b	L	L1	h1	f					
MWWNRL/L2020K08	WN□□0804□□	20	20	125	32	20	25	MW0804	CTM617	HL1813	ML0625	L3.0
MWWNRL/L2525M08		25	25	150	32	25	32					
MWWNRL/L3232P08		32	32	170	32	32	40					

▲更多型号可咨询，可接受高要求非标定制

MWWNR/L-B

主偏角50°
Tool cutting edge angle 50°

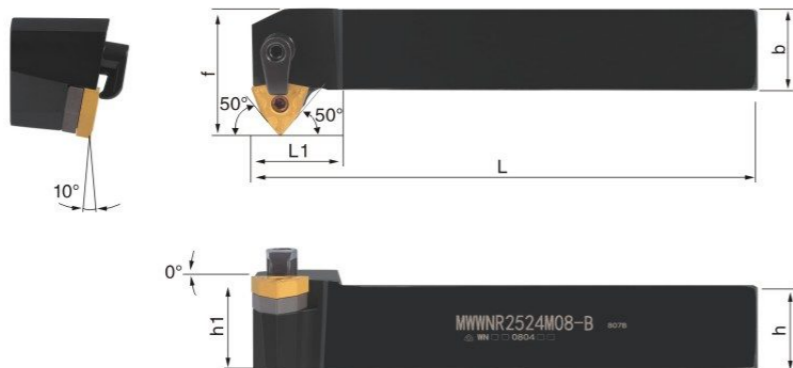
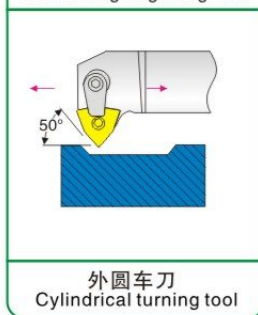

型号 Type	刀片 Blade	规格 Specification						刀垫 Shim	销钉 Pin	压板 Clamp	双头螺丝 Screw	扳手 Wrench
		h	b	L	L1	h1	f					
MWWNR/L2020K08-B	WN□□0804□□	20	20	125	26	20	33.5	MW0804	CTM617	HL1813	ML0625	L3.0
MWWNR/L2524M08-B		25	24	150	26	25	37.5					

▲更多型号可咨询，可接受高要求非标定制

WWLNR/L

主偏角95°
Tool cutting edge angle 95°

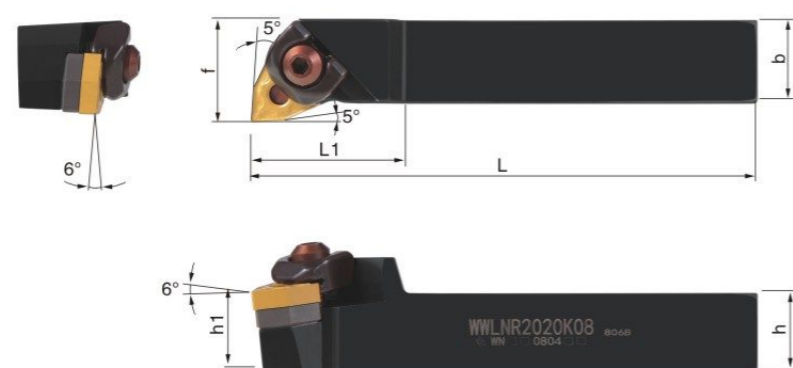
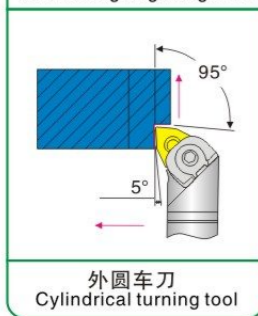

型号 Type	刀片 Blade	规格 Specification						刀垫 Shim	刀垫螺钉 Shim screw	压板 Clamp	压板螺钉 Plate screws	扳手 Wrench
		h	b	L	L1	h1	f					
WWLNR/L2020K06	WN□□0604□□	20	20	125	33	20	25	MW0604	CT515	WW06	M6×21	L2.5 L3.0
WWLNR/L2525M06		25	25	150	33	25	32					
WWLNR/L1616H08	WN□□0804□□	16	16	100	33	16	25	MW0804	CT618	HLW-08	M5×25	L3.0 L4.0
WWLNR/L2020K08		20	20	125	38	20	25					
WWLNR/L2525M08		25	25	150	38	25	32					
WWLNR/L3232P08		32	32	170	38	32	40					

▲更多型号可咨询，可接受高要求非标定制

SCLCR/L

主偏角95°
Tool cutting edge angle 95°

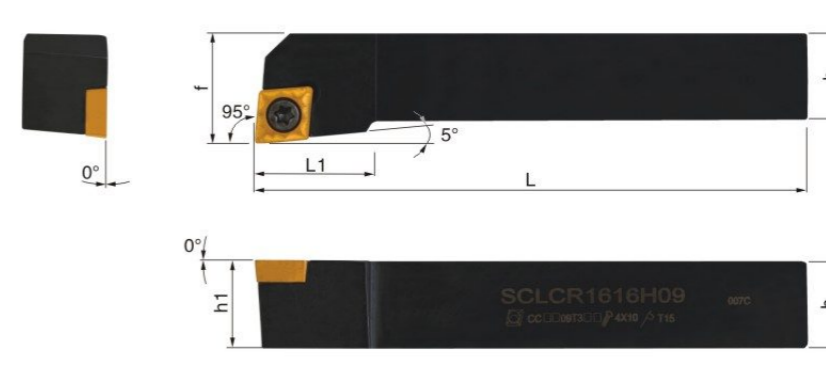
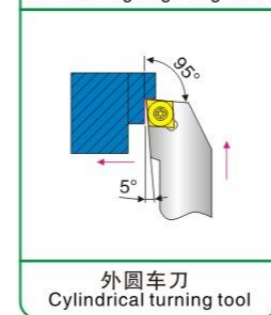

型号 Type	刀片 Blade	规格 Specification						螺丝 Screw	扳手 Wrench
		h	b	L	L1	h1	f		
SCLCR/L0808F06	CC□□0602□□	08	08	80	10	08	10	M2.5×7	T8
SCLCR/L1010H06		10	10	100	12	10	12		
SCLCR/L1212H06		12	12	100	12	12	16		
SCLCR/L1212H09	CC□□09T3□□	12	12	100	18	12	16	M4×10	T15
SCLCR/L1414H09		14	14	100	18	14	16		
SCLCR/L1616H09		16	16	100	18	16	20		
SCLCR/L2020K09		20	20	125	20	20	25		
SCLCR/L2525M09	CC□□1204□□	25	25	150	24	25	32	M5×12	T20
SCLCR/L2020K12		20	20	125	23	20	25		
SCLCR/L2525M12		25	25	150	26	25	32		
SCLCR/L3232P12		32	32	170	28	32	40		

▲更多型号可咨询，可接受高要求非标定制

SCKCR/L

主偏角75°
Tool cutting edge angle 75°

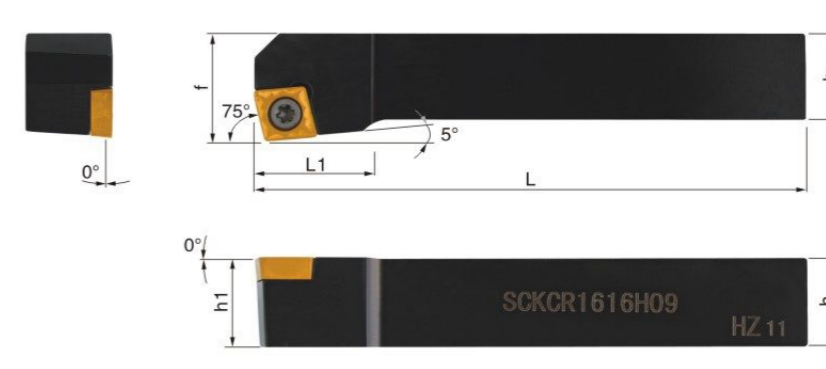
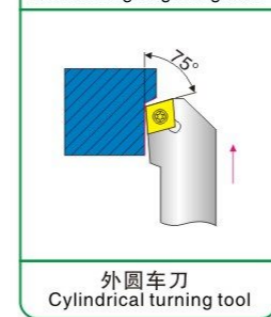

型号 Type	刀片 Blade	规格 Specification						螺丝 Screw	扳手 Wrench
		h	b	L	L1	h1	f		
SCKCR/L1212H09	CC□□09T3□□	12	12	100	20	12	16	M4×10	T15
SCKCR/L1414H09		14	14	100	20	14	16		
SCKCR/L1616H09		16	16	100	20	16	20		
SCKCR/L2020K09		20	20	125	23	20	25		
SCKCR/L2525M09	CC□□1204□□	25	25	150	23	25	32	M5×12	T20
SCKCR/L2020K12		20	20	125	23	20	25		
SCKCR/L2525M12		25	25	150	25	25	32		

▲更多型号可咨询，可接受高要求非标定制

SCFCR/L

主偏角91°
Tool cutting edge angle 91°

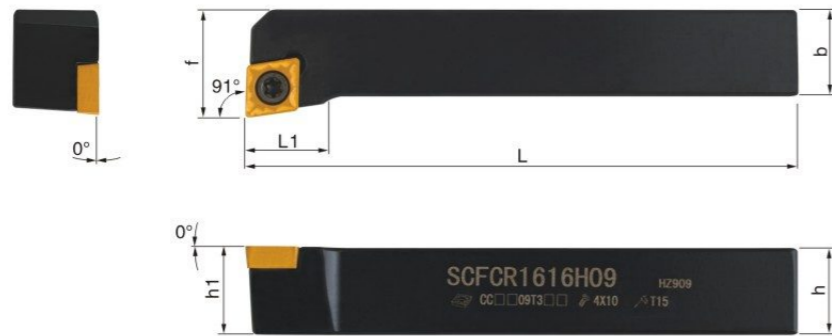
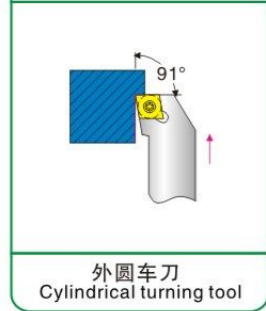

型号 Type	刀片 Blade	规格 Specification						螺丝 Screw	扳手 Wrench
		h	b	L	L1	h1	f		
SCFCR/L1212H06	CC□□0602□□	12	12	100	16	12	16	M2.5×7	T8
SCFCR/L1414H09	CC□□09T3□□	14	14	100	20	14	16		
SCFCR/L1616H09		16	16	100	20	16	20		
SCFCR/L2020K09		20	20	125	20	20	25		
SCFCR/L2525M12	CC□□1204□□	25	25	150	25	25	32	M5×12	T20
SCFCR/L3232P12		32	32	170	25	32	40		

▲更多型号可咨询, 可接受高要求非标定制

SCMCN-100

主偏角40°
Tool cutting edge angle 40°

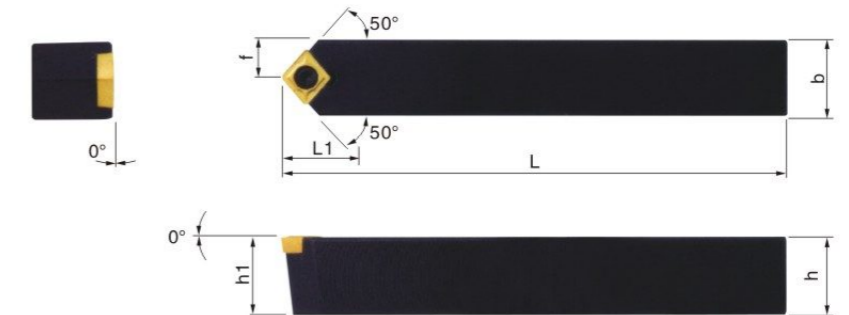
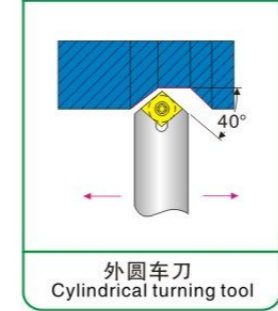

型号 Type	刀片 Blade	规格 Specification						螺丝 Screw	扳手 Wrench
		h	b	L	L1	h1	f		
SCMCN1010H06-100	CC□□0602□□	10	10	100	13	10	5	M2.5×7	T8
SCMCN1212H09-100	CC□□09T3□□	12	12	100	18	12	6		
SCMCN1414H09-100		14	14	100	18	14	7		
SCMCN1616H09-100		16	16	100	18	16	8		
SCMCN2020K09-100		20	20	125	18	20	10		
SCMCN2525M09-100	CC□□1204□□	25	25	150	18	25	12.5	M5×12	T20
SCMCN2020K12-100		20	20	125	23	20	10		
SCMCN2525M12-100		25	25	150	23	25	12.5		

▲更多型号可咨询, 可接受高要求非标定制

SCMCN

主偏角50°
Tool cutting edge angle 50°

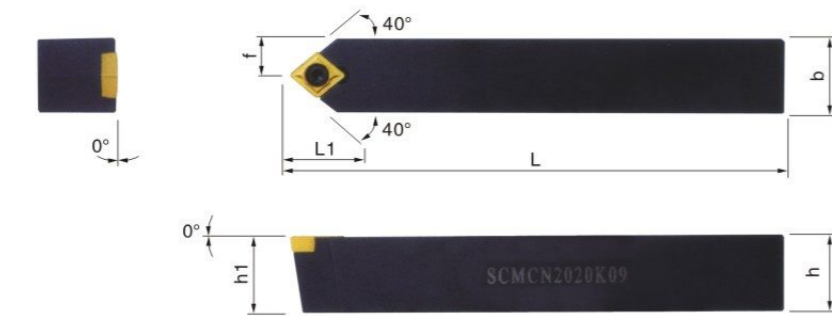
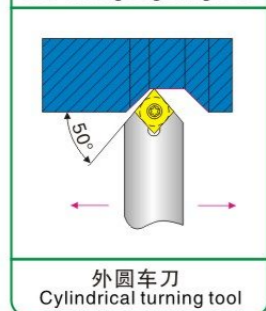

型号 Type	刀片 Blade	规格 Specification						螺丝 Screw	扳手 Wrench
		h	b	L	L1	h1	f		
SCMCN0808H06	CC□□0602□□	8	8	100	13	8	4	M2.5×7	T8
SCMCN1010H06		10	10	100	13	10	5		
SCMCN1212H09		12	12	100	18	12	6		
SCMCN1414H09	CC□□09T3□□	14	14	100	13	14	7	M4×10	T15
SCMCN1616H09		16	16	100	18	16	8		
SCMCN2020K09		20	20	125	18	20	10		
SCMCN2525M09		25	25	150	18	25	12.5		
SCMCN2020K12	CC□□1204□□	20	20	125	23	20	10	M5×12	T20
SCMCN2525M12		25	25	150	23	25	12.5		

▲更多型号可咨询, 可接受高要求非标定制

SCGCR/L

主偏角91°
Tool cutting edge angle 91°



型号 Type	刀片 Blade	规格 Specification						螺丝 Screw	扳手 Wrench
		h	b	L	L1	h1	f		
SCGCR/L0808F06	CC□□0602□□	08	08	80	10	08	10	M2.5×7	T8
SCGCR/L1010H06		10	10	100	12	10	12		
SCGCR/L1212H06		12	12	100	12	12	16		
SCGCR/L1212H09	CC□□09T3□□	12	12	100	18	12	16	M4×10	T15
SCGCR/L1616H09		16	16	100	18	16	20		
SCGCR/L2020K09		20	20	125	20	20	25		
SCGCR/L2525M09		25	25	150	24	25	32		
SCGCR/L2020K12	CC□□1204□□	20	20	125	23	20	25	M5×12	T20
SCGCR/L2525M12		25	25	150	26	25	32		
SCGCR/L3232P12		32	32	170	28	32	40		

▲更多型号可咨询, 可接受高要求非标定制

SCBCR/L

主偏角75°
Tool cutting edge angle 75°

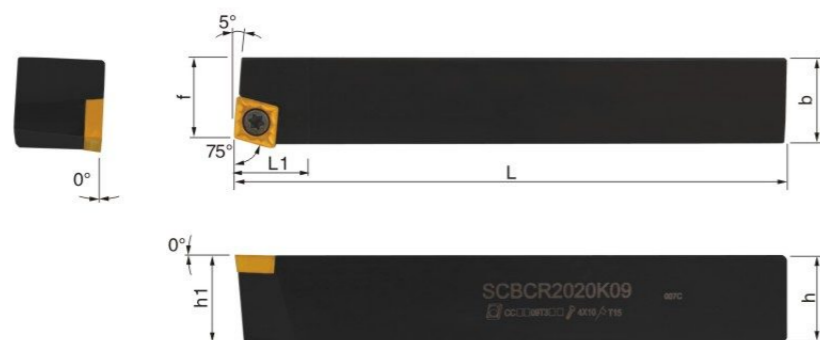
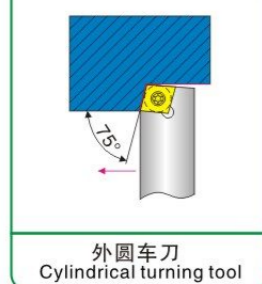

型号 Type	刀片 Blade	规格 Specification						螺丝 Screw	扳手 Wrench
		h	b	L	L1	h1	f		
SCBCR/L1212H09	CC□□09T3□□	12	12	100	13	12	9.5	M4 × 10	T15
SCBCR/L1616H09		16	16	100	15	16	13		
SCBCR/L2020K09		20	20	125	12	20	17		
SCBCR/L2525M09		25	25	150	12	25	22		
SCBCR/L1616H12	CC□□1204□□	16	16	100	20	16	13	M5 × 12	T20
SCBCR/L2020K12		20	20	125	16	20	17		
SCBCR/L2525M12		25	25	150	16	25	22		

▲更多型号可咨询, 可接受高要求非标定制

SCACR/L

主偏角90°
Tool cutting edge angle 90°

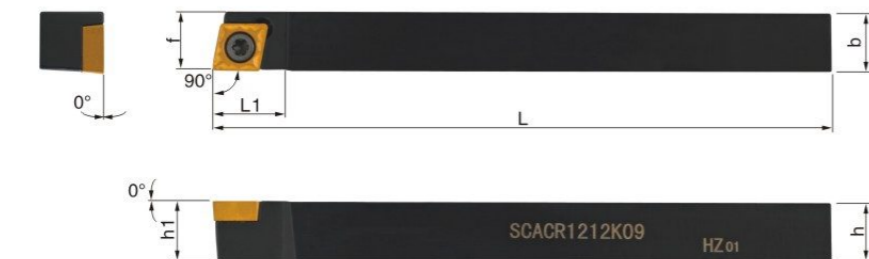
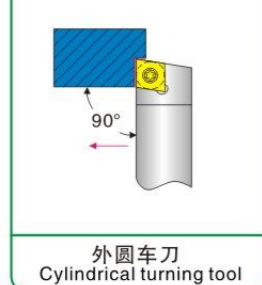

型号 Type	刀片 Blade	规格 Specification						螺丝 Screw	扳手 Wrench
		h	b	L	L1	h1	f		
SCACR/L0808K06	CC□□0602□□	8	8	125	10	8	8	M2.5 × 7	T8
SCACR/L1010K06		10	10	125	10	10	10		
SCACR/L1212K09	CC□□09T3□□	12	12	125	13	12	12	M4 × 10	T15
SCACR/L1414K09		14	14	125	13	14	14		
SCACR/L1616K09		16	16	125	13	16	16		

▲更多型号可咨询, 可接受高要求非标定制

SDJCR/L

主偏角93°
Tool cutting edge angle 93°

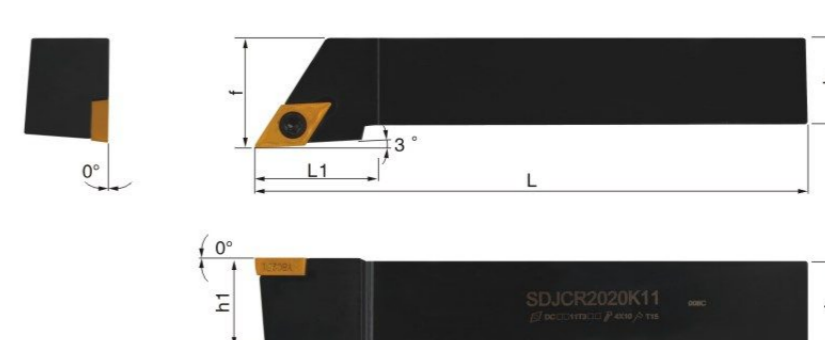
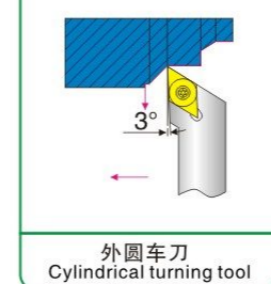

型号 Type	刀片 Blade	规格 Specification						螺丝 Screw	扳手 Wrench
		h	b	L	L1	h1	f		
SDJCR/L1010H07	DC□□0702□□	10	10	100	14	10	12	M2.5 × 7	T8
SDJCR/L1212H07		12	12	100	14	12	16		
SDJCR/L1616H07		16	16	100	14	16	20		
SDJCR/L1212H11	DC□□11T3□□	12	12	100	20	12	16	M4 × 10	T15
SDJCR/L1414H11		14	14	100	20	14	16		
SDJCR/L1616H11		16	16	100	20	16	20		
SDJCR/L2020K11		20	20	125	20	20	25		
SDJCR/L2525M11		25	25	150	22	25	32		
SDJCR/L3232P11		32	32	170	23	32	40		
SDJCR/L4040R11		40	40	200	25	40	50		

▲更多型号可咨询, 可接受高要求非标定制

SDACR/L

主偏角90°
Tool cutting edge angle 90°

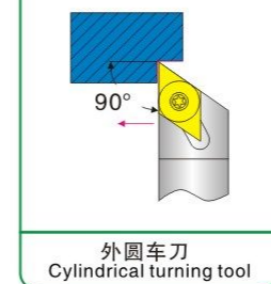

型号 Type	刀片 Blade	规格 Specification						螺丝 Screw	扳手 Wrench
		h	b	L	L1	h1	f		
SDACR/L0808H07	DC□□0702□□	8	8	100	15	8	8	M2.5 × 7	T8
SDACR/L1010H07		10	10	100	15	10	10		
SDACR/L1212H07		12	12	100	15	12	12		
SDACR/L1212H11	DC□□11T3□□	12	12	100	22	12	12	M4 × 10	T15
SDACR/L1414H11		14	14	100	22	14	14		
SDACR/L1616H11		16	16	100	22	16	16		
SDACR/L2020K11		20	20	125	22	20	20		
SDACR/L2525M11		25	25	150	22	25	25		

▲更多型号可咨询, 可接受高要求非标定制

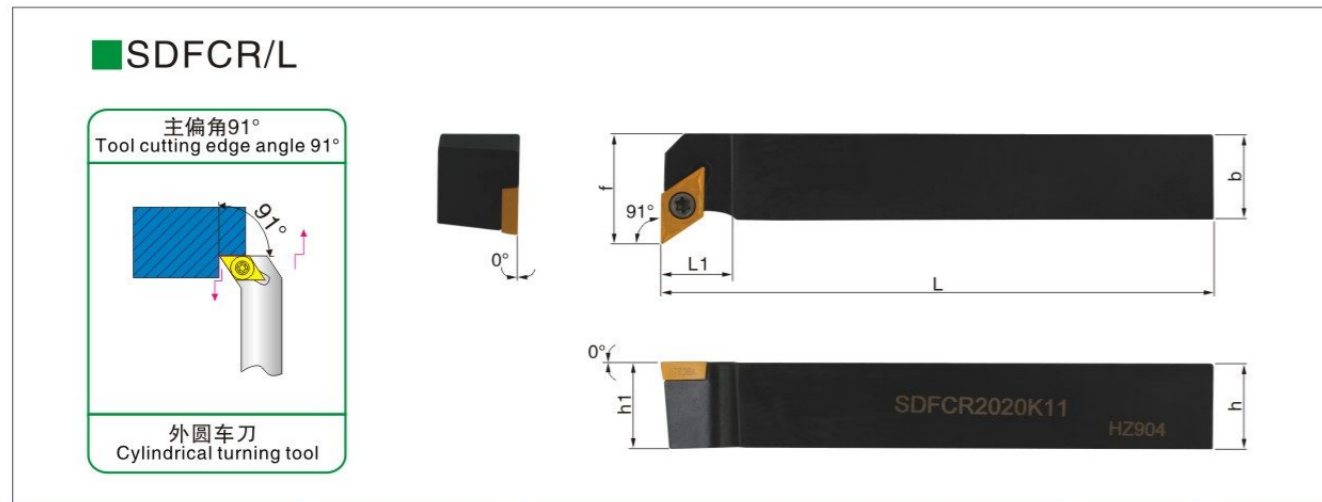

型号 Type	刀片 Blade	规格 Specification						螺丝 Screw	扳手 Wrench
		h	b	L	L1	h1	f		
SDFCR/L1212H07	DC□□0702□□	12	12	100	8	12	16	M2.5×7	T8
SDFCR/L1616H11	DC□□11T3□□	16	16	100	14	16	20	M4×10	T15
SDFCR/L2020K11		20	20	125	14	20	25		

▲更多型号可咨询, 可接受高要求非标定制

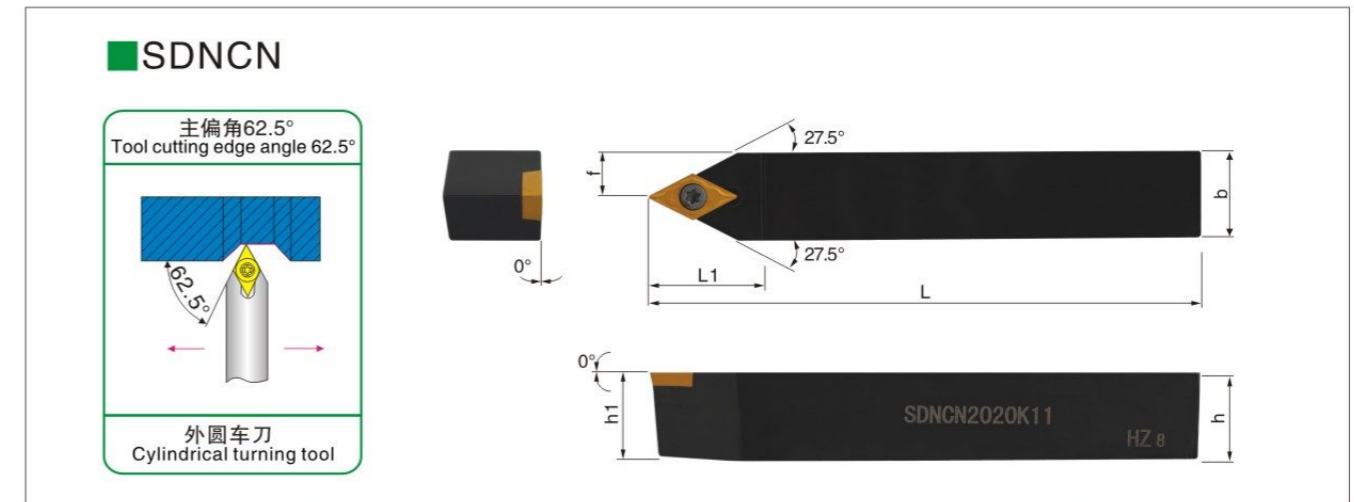

型号 Type	刀片 Blade	规格 Specification						螺丝 Screw	扳手 Wrench
		h	b	L	L1	h1	f		
SDNCN1010H07	DC□□0702□□	10	10	100	14	10	5	M2.5×7	T8
SDNCN1212H07		12	12	100	14	12	6		
SDNCN1212H11		12	12	100	21	12	6		
SDNCN1414H11	DC□□11T3□□	14	14	100	21	14	7	M4×10	T15
SDNCN1616H11		16	16	100	21	16	8		
SDNCN2020K11		20	20	125	21	20	10		

▲更多型号可咨询, 可接受高要求非标定制

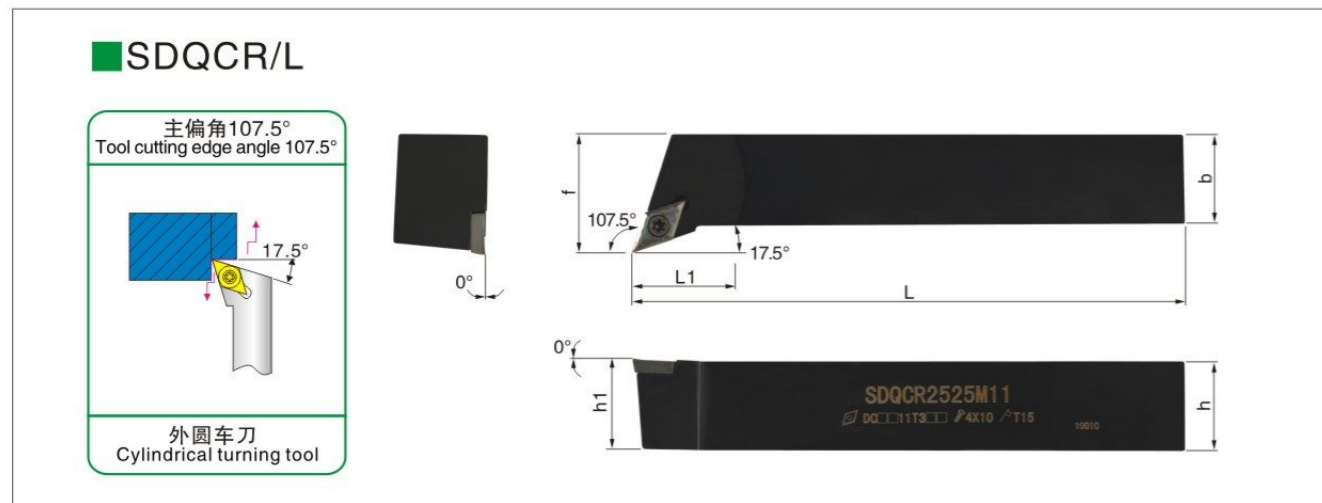

型号 Type	刀片 Blade	规格 Specification						螺丝 Screw	扳手 Wrench
		h	b	L	L1	h1	f		
SDQCR/L1010H07	DC□□0702□□	10	10	100	13	10	12	M2.5×7	T8
SDQCR/L1212H07		12	12	100	13	12	16		
SDQCR/L1212H11		12	12	100	14	12	16		
SDQCR/L1616H11	DC□□11T3□□	16	16	100	14	16	20	M4×10	T15
SDQCR/L2020K11		20	20	125	16	20	25		
SDQCR/L2525M11		25	25	150	20	25	32		

▲更多型号可咨询, 可接受高要求非标定制

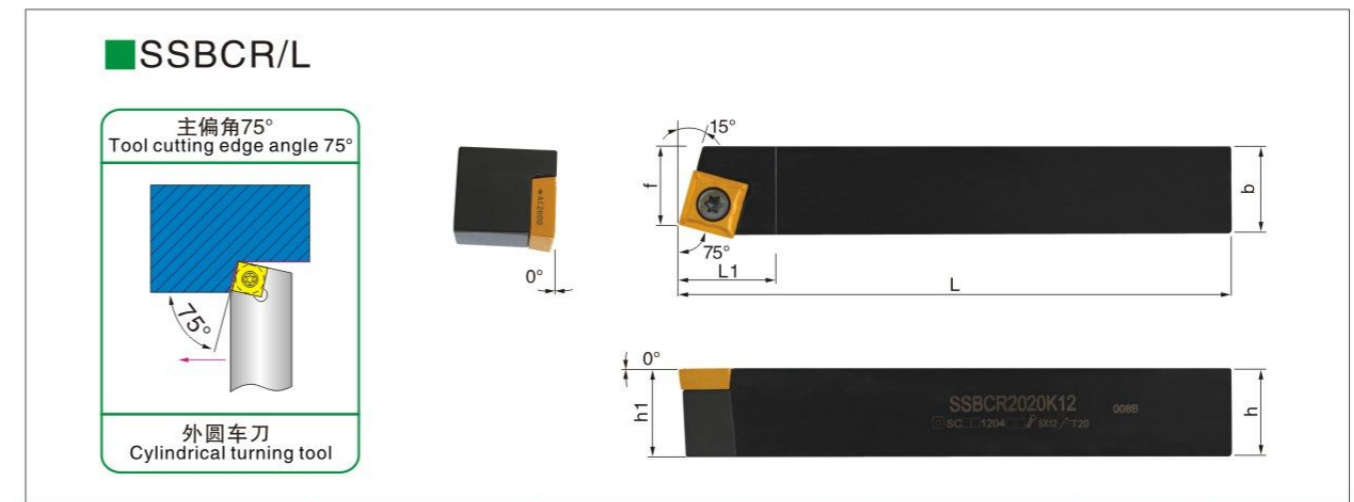

型号 Type	刀片 Blade	规格 Specification						螺丝 Screw	扳手 Wrench
		h	b	L	L1	h1	f		
SSBCR/L1212H09	SC□□09T3□□	12	12	100	14	12	9.5	M4×10	T15
SSBCR/L1616H09		16	16	100	14	16	13		
SSBCR/L2020K09		20	20	125	30	20	17		
SSBCR/L2525M09		25	25	150	32	25	22		
SSBCR/L2020K12	SC□□1204□□	20	20	125	30	20	17	M5×12	T20
SSBCR/L2525M12		25	25	150	25	22	22		

▲更多型号可咨询, 可接受高要求非标定制

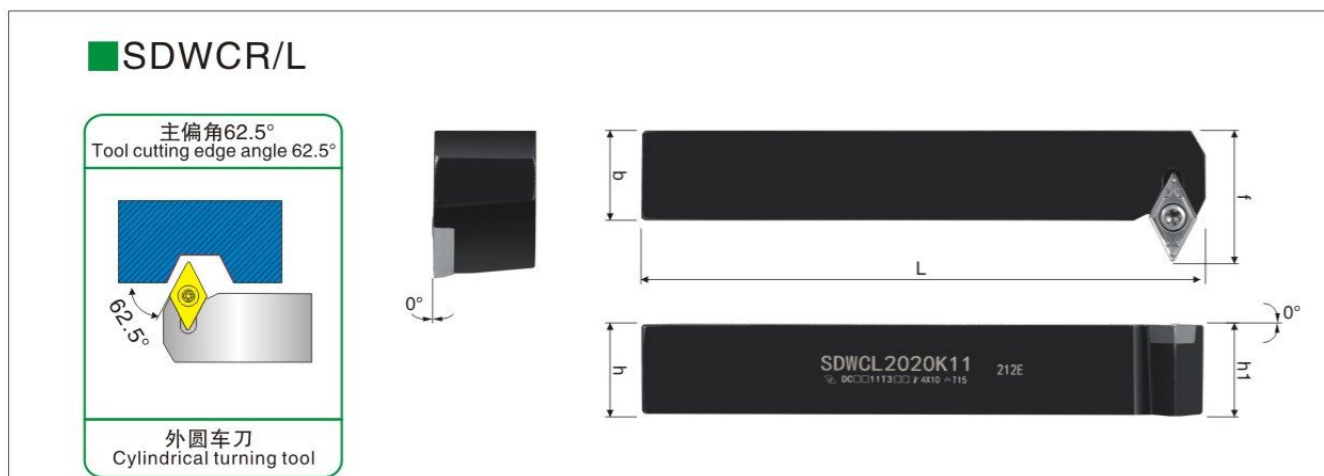

型号 Type	刀片 Blade	规格 Specification					螺丝 Screw	扳手 Wrench
		h	b	L	h1	f		
SDWCR/L1616H11	DC□□11T3□□	16	16	100	16	26	M4 x 10	T15
SDWCR/L2020K11		20	20	125	20	29		
SDWCR/L2525M11		25	25	150	25	34		

▲更多型号可咨询, 可接受高要求非标定制

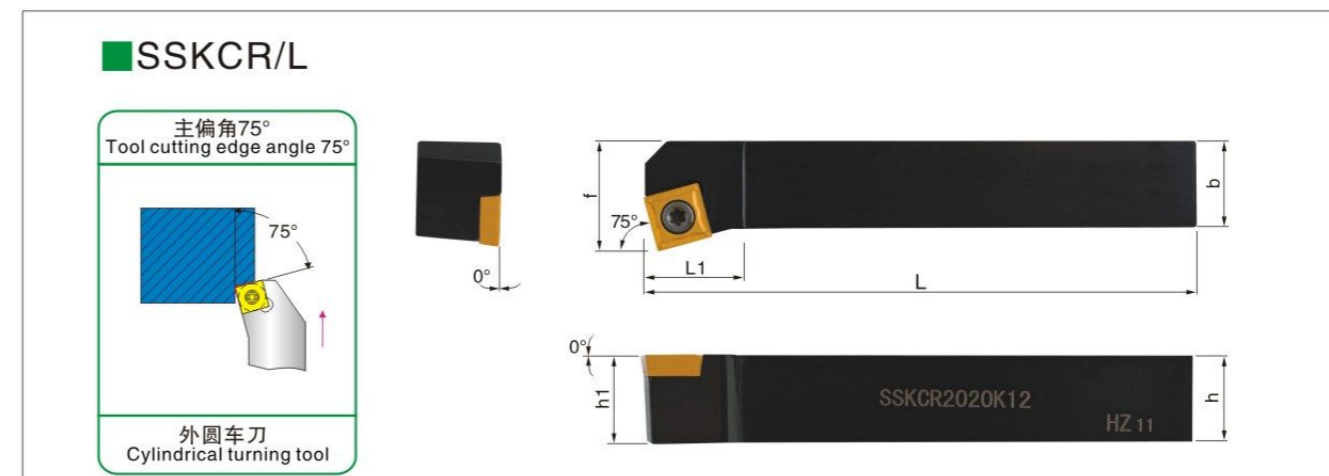

型号 Type	刀片 Blade	规格 Specification						螺丝 Screw	扳手 Wrench
		h	b	L	L1	h1	f		
SSKCR/L1212H09	SC□□09T3□□	12	12	100	15	12	16	M4 x 10	T15
SSKCR/L1616H09		16	16	100	20	16	20		
SSKCR/L2020K09		20	20	125	25	20	25		
SSKCR/L2525M09		25	25	150	22	25	32		
SSKCR/L2020K12	SC□□1204□□	20	20	125	20	20	25	M5 x 10	T20

▲更多型号可咨询, 可接受高要求非标定制

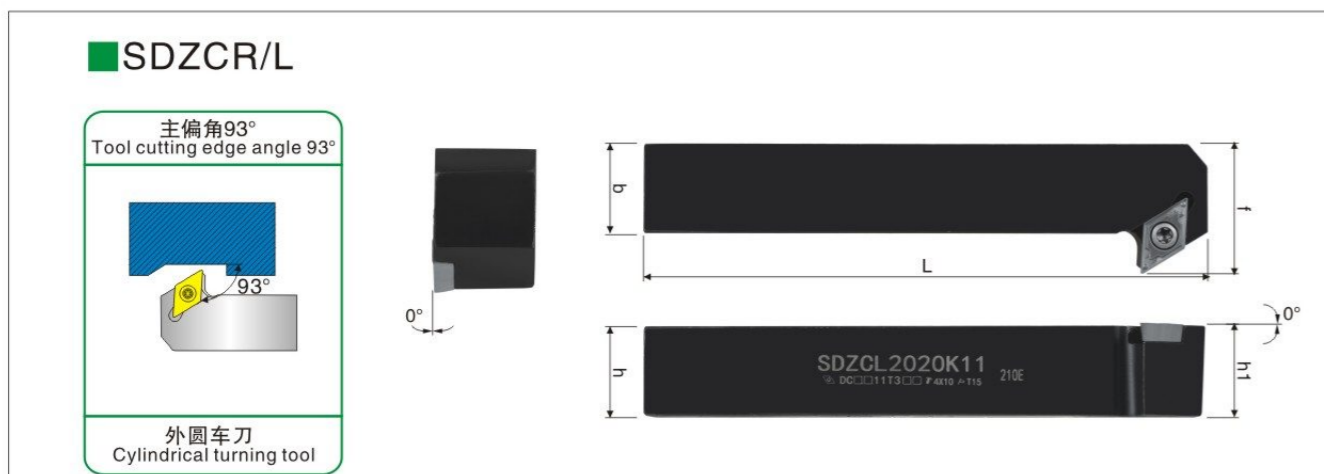

型号 Type	刀片 Blade	规格 Specification					螺丝 Screw	扳手 Wrench
		h	b	L	h1	f		
SDZCR/L1616H11	DC□□11T3□□	16	16	100	16	25	M4 x 10	T15
SDZCR/L2020K11		20	20	125	20	29		
SDZCR/L2525M11		25	25	150	25	34		

▲更多型号可咨询, 可接受高要求非标定制

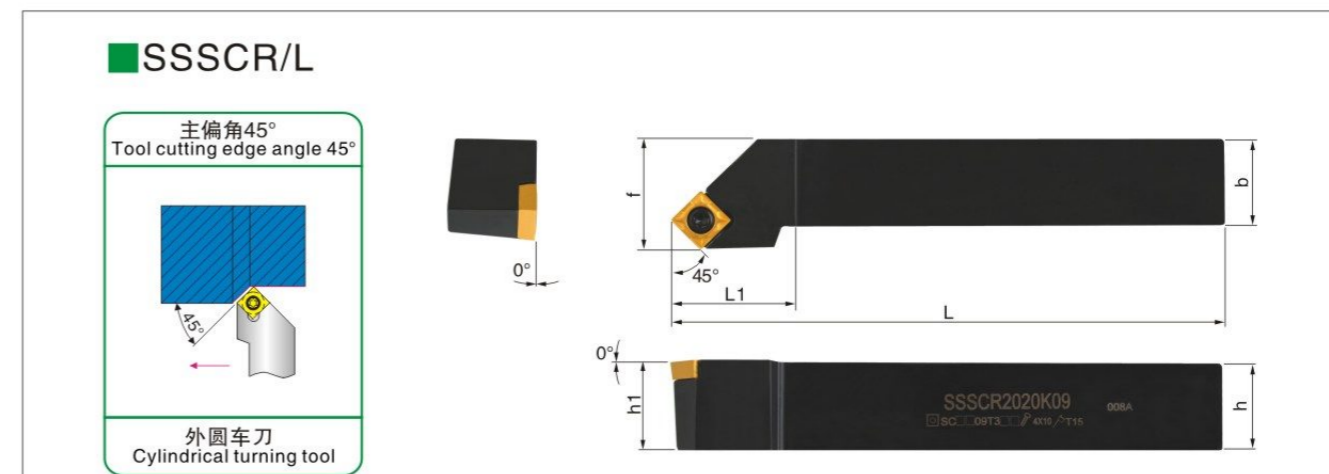

型号 Type	刀片 Blade	规格 Specification						螺丝 Screw	扳手 Wrench
		h	b	L	L1	h1	f		
SSSCR/L1212H09	SC□□09T3□□	12	12	100	16	20	16	M4 x 10	T15
SSSCR/L1616H09		16	16	100	16	16	20		
SSSCR/L2020K09		20	20	125	18	20	25		
SSSCR/L2525M09		25	25	150	26	25	32		
SSSCR/L2525M12	SC□□1204□□	25	25	150	25	25	32	M5 x 12	T20

▲更多型号可咨询, 可接受高要求非标定制

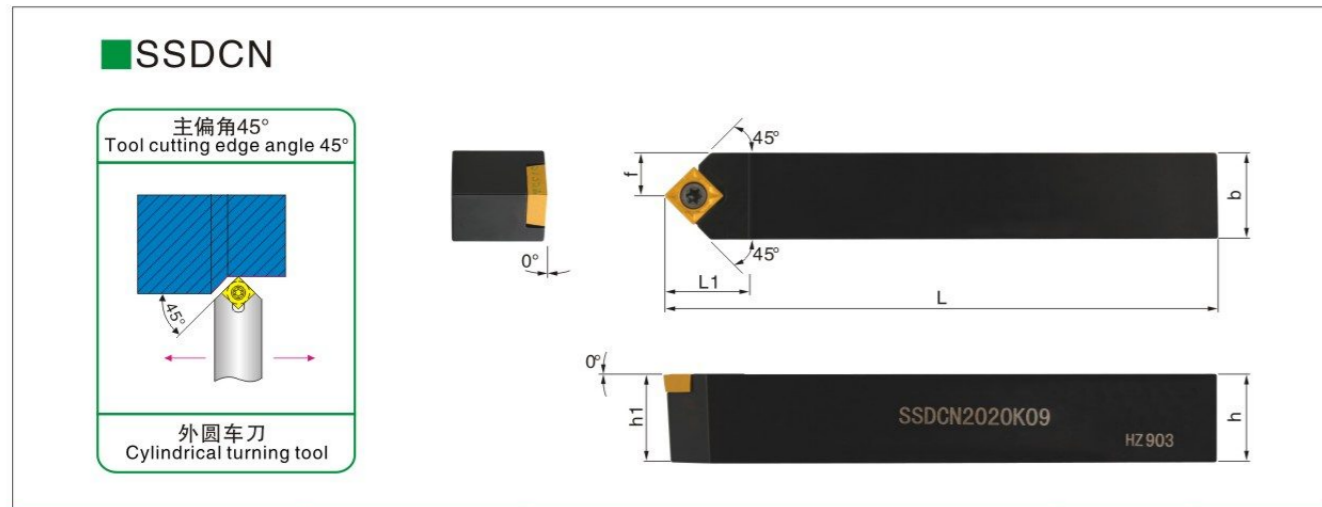

型号 Type	刀片 Blade	规格 Specification						螺丝 Screw	扳手 Wrench
		h	b	L	L1	h1	f		
SSDCN1212H09	SC□□09T3□□	12	12	100	16	12	6	M4 x 10	T15
SSDCN1414H09		14	14	100	16	14	7		
SSDCN1616H09		16	16	100	16	16	8		
SSDCN2020K09		20	20	125	16	20	10		
SSDCN2525M09		25	25	150	16	25	16		

▲更多型号可咨询，可接受高要求非标定制

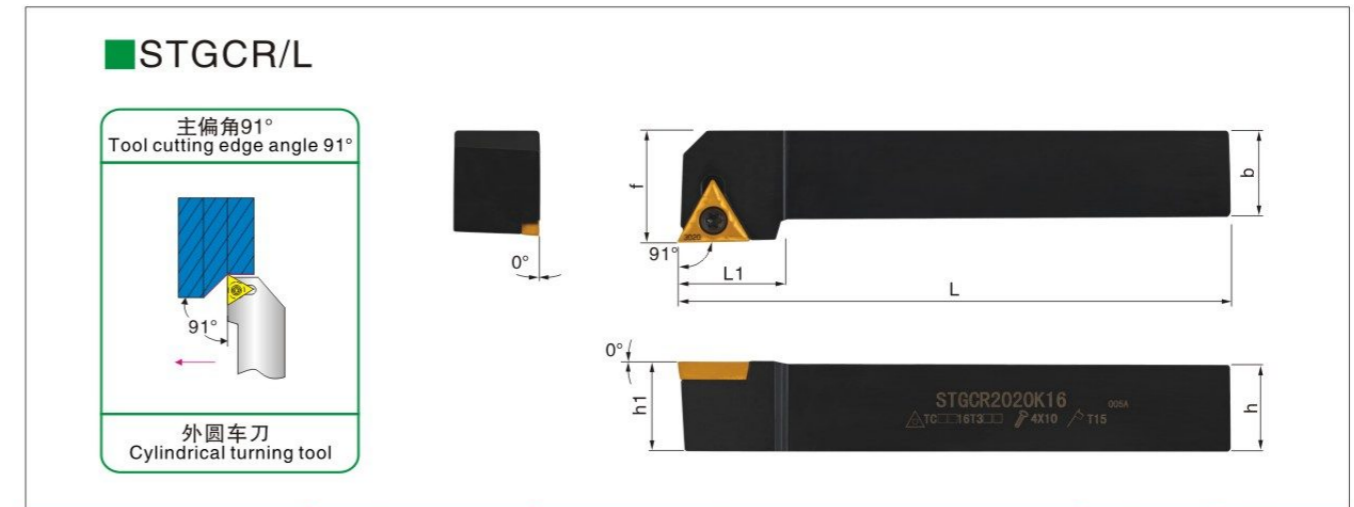

型号 Type	刀片 Blade	规格 Specification						螺丝 Screw	扳手 Wrench
		h	b	L	L1	h1	f		
STGCR/L0808H09	TC□□0902□□	08	08	100	10	08	10	M2.5 x 7	T8
STGCR/L1010H09		10	10	100	12	10	12		
STGCR/L1212H11		12	12	100	16	12	16		
STGCR/L1616H11	TC□□1102□□	16	16	100	20	12	20	M4 x 10	T15
STGCR/L1616H16		16	16	100	22	16	20		
STGCR/L2020K16		20	20	125	22	20	25		
STGCR/L2525M16		25	25	150	22	20	32		
STGCR/L3232P16		32	32	170	22	25	40		

▲更多型号可咨询，可接受高要求非标定制

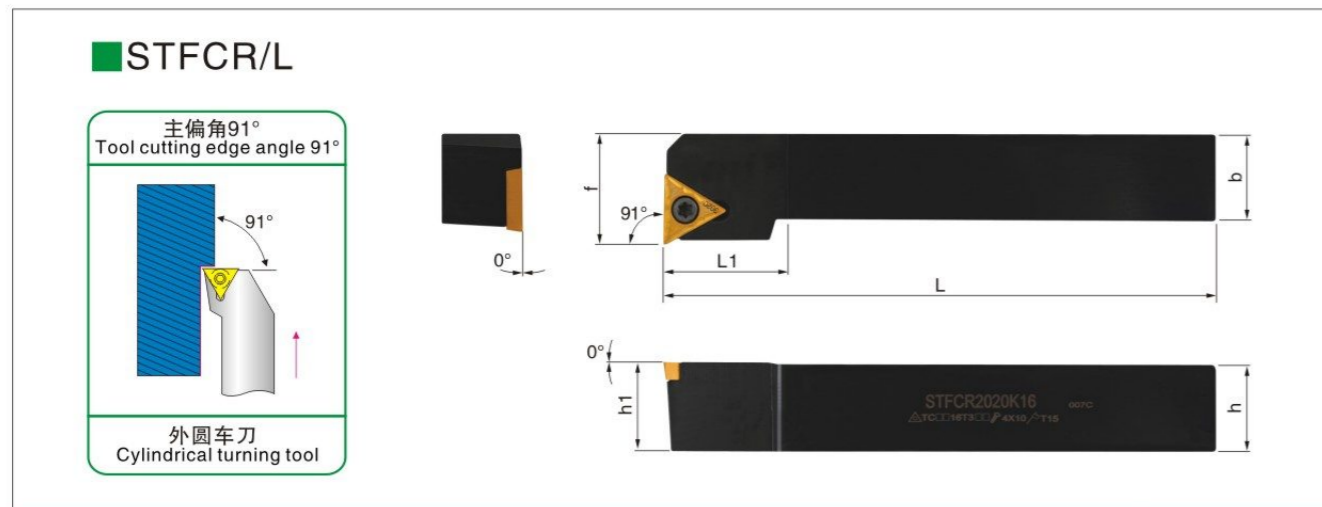

型号 Type	刀片 Blade	规格 Specification						螺丝 Screw	扳手 Wrench
		h	b	L	L1	h1	f		
STFCR/L1010H09	TC□□0902□□	10	10	100	12	10	12	M2.5 x 7	T8
STFCR/L1212H11		12	12	100	16	12	16		
STFCR/L1414H11		14	14	100	16	14	16		
STFCR/L1616H11		16	16	100	16	16	20		
STFCR/L1616H16	TC□□16T3□□	16	16	100	16	16	20	M4 x 10	T15
STFCR/L2020K16		20	20	125	22	20	25		
STFCR/L2525M16		25	25	150	22	25	32		

▲更多型号可咨询，可接受高要求非标定制

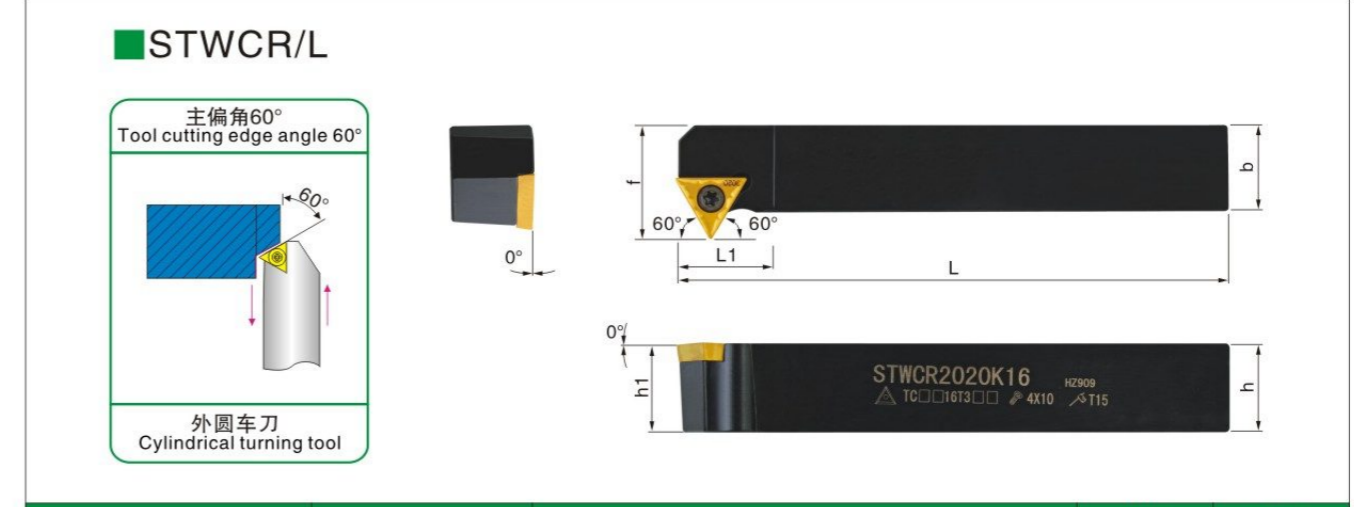

型号 Type	刀片 Blade	规格 Specification						螺丝 Screw	扳手 Wrench
		h	b	L	L1	h1	f		
STWCR/L1212H11	TC□□1102□□	12	12	100	8	12	15.3	M2.5 x 7	T8
STWCR/L1616H11		16	16	100	8	16	19.3		
STWCR/L2020K11		20	20	125	8	20	23.3		
STWCR/L2525M11		25	25	150	8	25	28.3		
STWCR/L1616H16	TC□□16T3□□	16	16	100	12	16	21	M4 x 10	T15
STWCR/L2020K16		20	20	125	12	20	26		
STWCR/L2525M16		25	25	150	12	25	31		
STWCR/L3232P16		32	32	170	12	32	38		

▲更多型号可咨询，可接受高要求非标定制

STECR/L

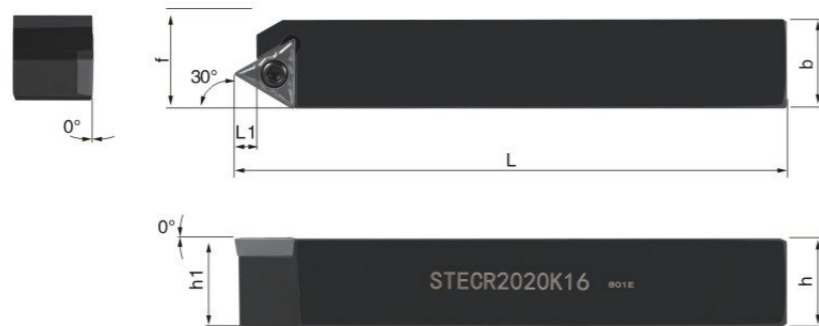
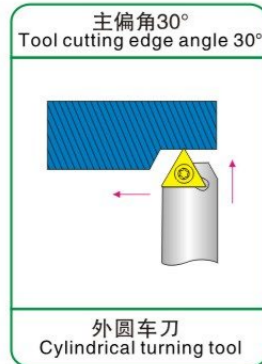

型号 Type	刀片 Blade	规格 Specification						螺丝 Screw	扳手 Wrench
		h	b	L	L1	h1	f		
STECR/L1414H11	TC□□1102□□	14	14	100	3.5	14	14	M2.5×7	T8
STECR/L1616H11		16	16	100	3.5	16	16		
STECR/L2020K16	TC□□16T3□□	20	20	125	5	20	20	M4×10	T15
STECR/L2525M16		25	25	150	5	25	25		

▲更多型号可咨询，可接受高要求非标定制

SVV*N

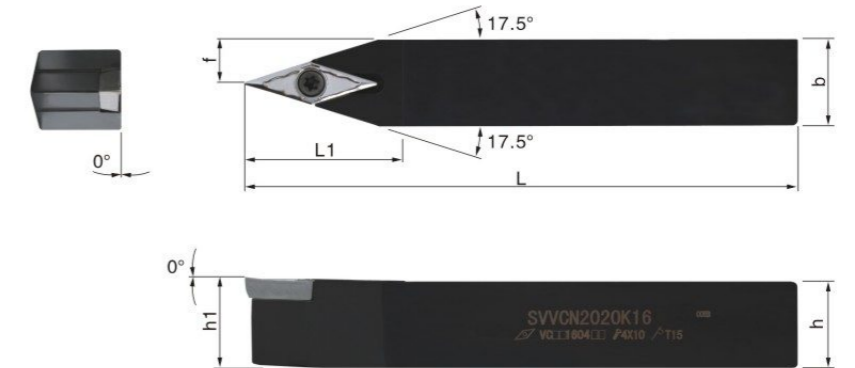
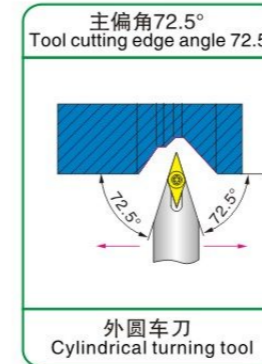

型号 Type	刀片 Blade	规格 Specification						螺丝 Screw	扳手 Wrench
		h	b	L	L1	h1	f		
SVV-N1010H11	VC□□1103□□ VB□□1103□□	10	12	100	25	10	5	M2.5×7	T8
SVV-N1212H11		12	12	100	28	12	6		
SVV-N1616H11		16	16	100	24	16	8		
SVV-N2020K11		20	20	125	24	20	10		
SVV-N2525M11		25	25	150	24	25	12.5		
SVV-N1616H16	VC□□1604□□ VB□□1604□□	16	16	100	34	16	8	M4×10	T15
SVV-N2020K16		20	20	125	34	20	10		
SVV-N2525M16		25	25	150	34	25	12.5		
SVV-N3232P16		32	32	170	34	32	16		

▲更多型号可咨询，可接受高要求非标定制

SVJ*R/L

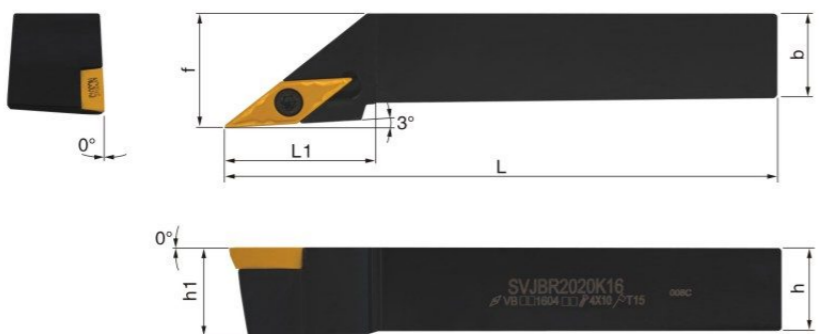
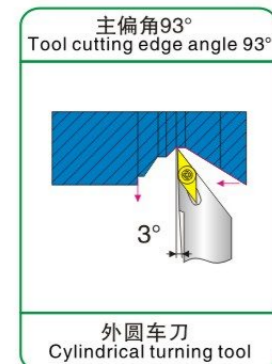

型号 Type	刀片 Blade	规格 Specification						螺丝 Screw	扳手 Wrench
		h	b	L	L1	h1	f		
SVJ-R/L1212H11	VB□□1103□□ VC□□1103□□	12	12	100	25	12	16	M2.5×7	T8
SVJ-R/L1616H11		16	16	100	28	16	20		
SVJ-R/L2020K11		20	20	125	32	20	25		
SVJ-R/L1616H16	VC□□1604□□ VB□□1604□□	16	16	100	32	16	20	M4×10	T15
SVJ-R/L2020K16		20	20	125	32	20	25		
SVJ-R/L2525M16		25	25	150	32	25	32		
SVJ-R/L3232P16		32	32	170	40	32	40		

▲更多型号可咨询，可接受高要求非标定制

SVQ*R/L

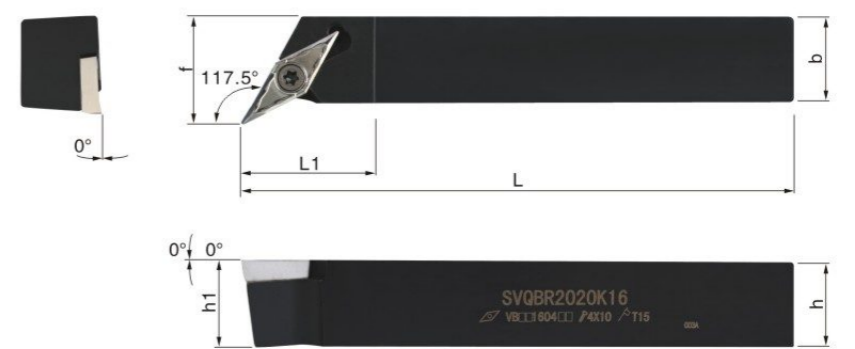
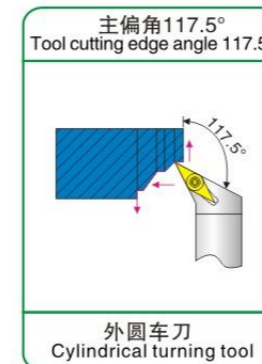

型号 Type	刀片 Blade	规格 Specification						螺丝 Screw	扳手 Wrench
		h	b	L	L1	h1	f		
SVQ-R/L1616H16	VC□□1604□□ VB□□1604□□	16	16	100	35	16	20	M4×10	T15
SVQ-R/L2020K16		20	20	125	35	20	25		
SVQ-R/L2525M16		25	25	150	35	25	32		
SVQ-R/L3232P16		32	32	170	35	32	40		

▲更多型号可咨询，可接受高要求非标定制

SVU*R/L

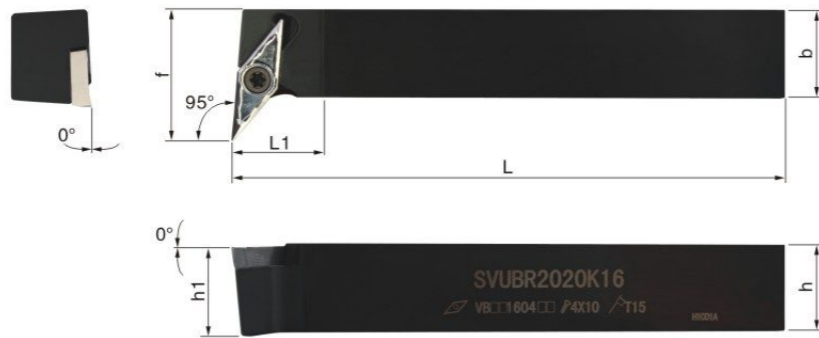
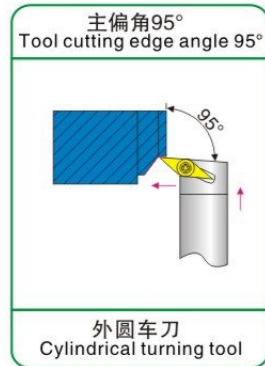

型号 Type	刀片 Blade	规格 Specification						螺丝 Screw	扳手 Wrench
		h	b	L	L1	h1	f		
SVU-R/L1616H11	VC□□1103□□ VB□□1103□□	16	16	100	12	16	20	M2.5×7	T8
SVU-R/L2020K11		20	20	125	16	20	25		
SVU-R/L1616H16	VC□□1604□□ VB□□1604□□	16	16	100	20	16	30	M4×10	T15
SVU-R/L2020K16		20	20	125	20	20	30		
SVU-R/L2525M16		25	25	150	16	25	32		
SVU-R/L3232P16		32	32	170	16	32	40		

▲更多型号可咨询, 可接受高要求非标定制

SVWBR/L

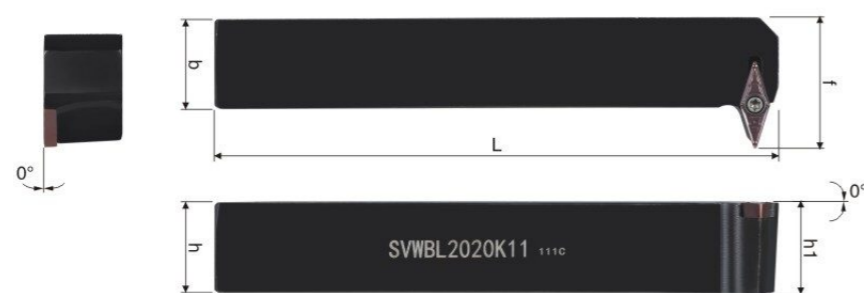
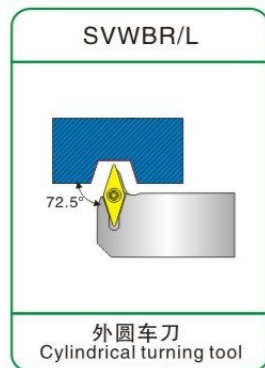

型号 Type	刀片 Blade	规格 Specification					螺丝 Screw	扳手 Wrench
		h	b	L	h1	f		
SVWBR/L1616H11	VB□□1103□□	16	16	100	16	26	M2.5X7	T8
SVWBR/L2020K11		20	20	125	20	30		
SVWBR/L2525M11		25	25	150	25	35		

▲更多型号可咨询, 可接受高要求非标定制

SVZBR/L

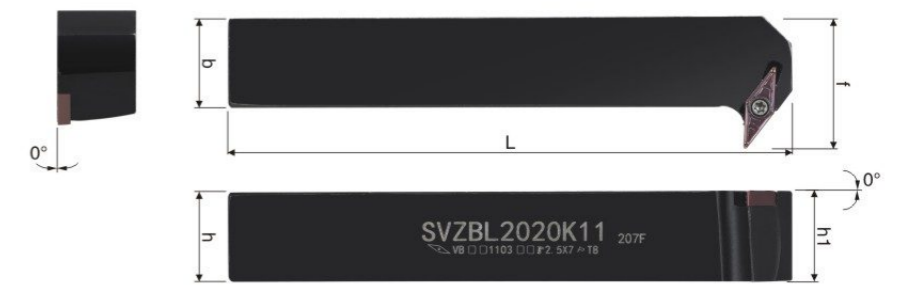
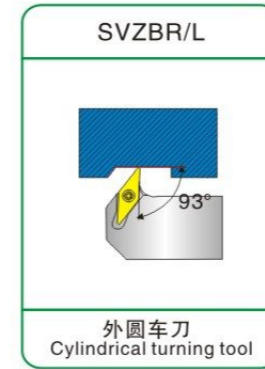

型号 Type	刀片 Blade	规格 Specification					螺丝 Screw	扳手 Wrench
		h	b	L	h1	f		
SVZBR/L1616H11	VB□□1103□□	16	16	100	16	26	M2.5X7	T8
SVZBR/L2020K11		20	20	125	20	30		
SVZBR/L2525M11		25	25	150	25	35		

▲更多型号可咨询, 可接受高要求非标定制

SRAPR/L

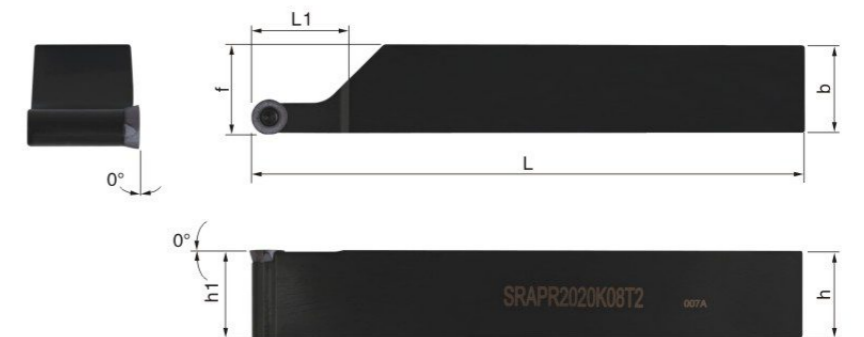
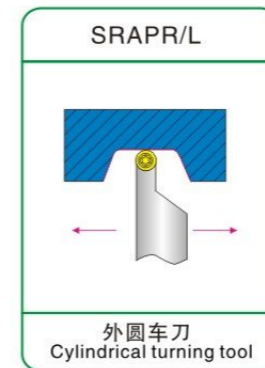

型号 Type	刀片 Blade	规格 Specification						螺丝 Screw	扳手 Wrench
		h	b	L	L1	h1	f		
SRAPR/L1616H08	RP□□08T2□□	16	16	100	16	16	16.5	M3×8	T8
SRAPR/L2020K08		20	20	125	16	20	20.5		
SRAPR/L2525M08		25	25	150	16	25	25.5		
SRAPR/L2020K10	RP□□10T3□□	20	20	125	20.3	20	20.6	M3.5×10	T15
SRAPR/L2525M10		25	25	150	20.3	25	25.6		
SRAPR/L2020K12	RP□□1204□□	20	20	125	25	20	20.8	M4×10	
SRAPR/L2525M12		25	25	150	25	25	25.8		

▲更多型号可咨询, 可接受高要求非标定制

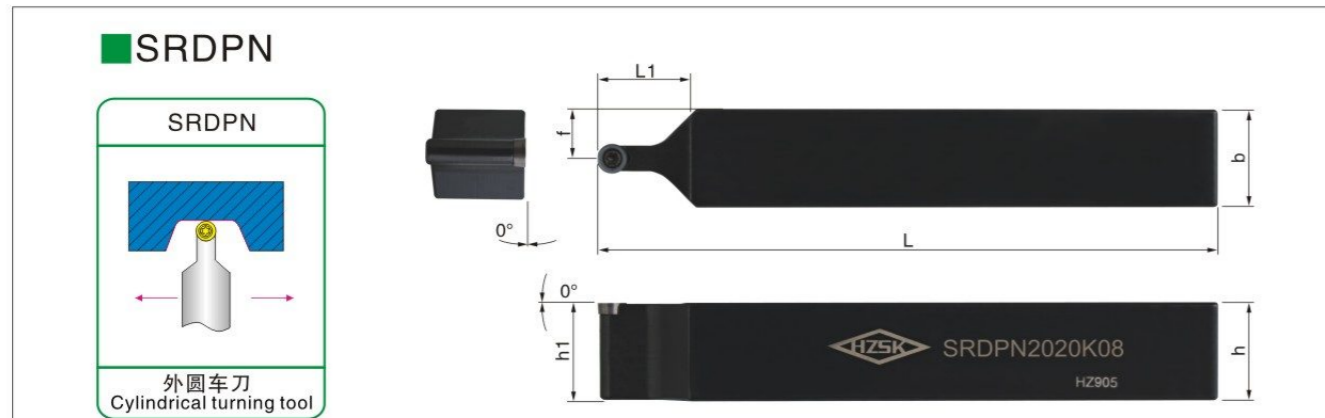

型号 Type	刀片 Blade	规格 Specification						螺丝 Screw	扳手 Wrench
		h	b	L	L1	h1	f		
SRDPN1616H08	RP□□08T2□□	16	16	100	16	16	8	M3×8	T8
SRDPN2020K08		20	20	125	16	20	10		
SRDPN2525M08		25	25	150	16	25	12.5		
SRDPN1010H10	RP□□10T3□□	10	10	100	20.3	10	5	M3.5×10	T15
SRDPN1616H10		16	16	100	20.3	16	8		
SRDPN2020K10		20	20	125	20.3	20	10		
SRDPN2525M10	RP□□1204□□	25	25	150	20.3	25	12.5	M4×10	
SRDPN2020K12		20	20	125	25	20	10		
SRDPN2525M12		25	25	150	25	25	12.5		

▲更多型号可咨询，可接受高要求非标定制

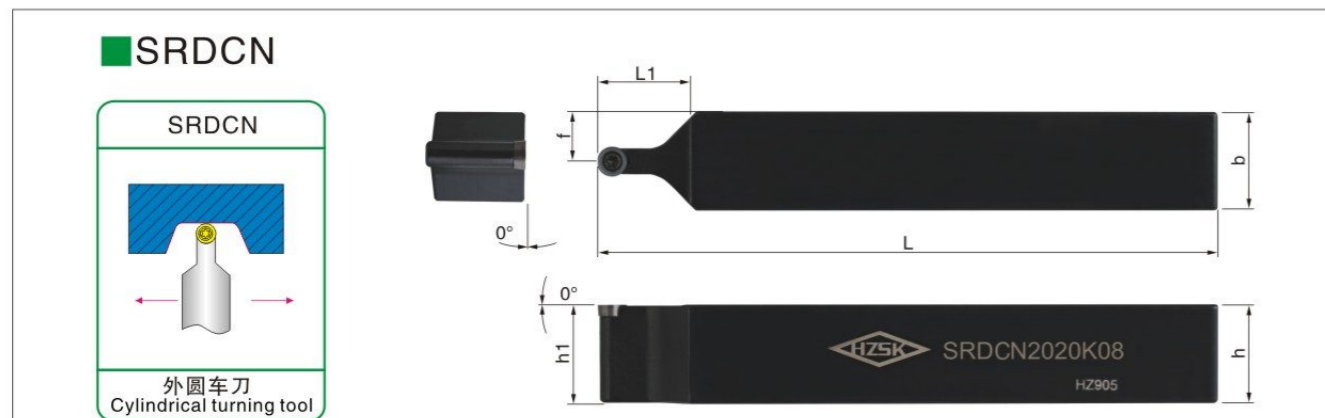

型号 Type	刀片 Blade	规格 Specification						螺丝 Screw	扳手 Wrench
		h	b	L	L1	h1	f		
SRDCN1616H08	RC□□0803□□	16	16	100	16	16	8	M3×8	T8
SRDCN2020K08		20	20	125	16	20	10		
SRDCN2525M08		25	25	150	16	25	12.5		
SRDCN1010H10	RC□□1003□□	10	10	100	20.3	10	5	M3.5×10	T15
SRDCN1616H10		16	16	100	20.3	16	8		
SRDCN2020K10		20	20	125	20.3	20	10		
SRDCN2525M10	RC□□1204□□	25	25	150	20.3	25	12.5	M4×10	
SRDCN2020K12		20	20	125	25	20	10		
SRDCN2525M12		25	25	150	25	25	12.5		

▲更多型号可咨询，可接受高要求非标定制

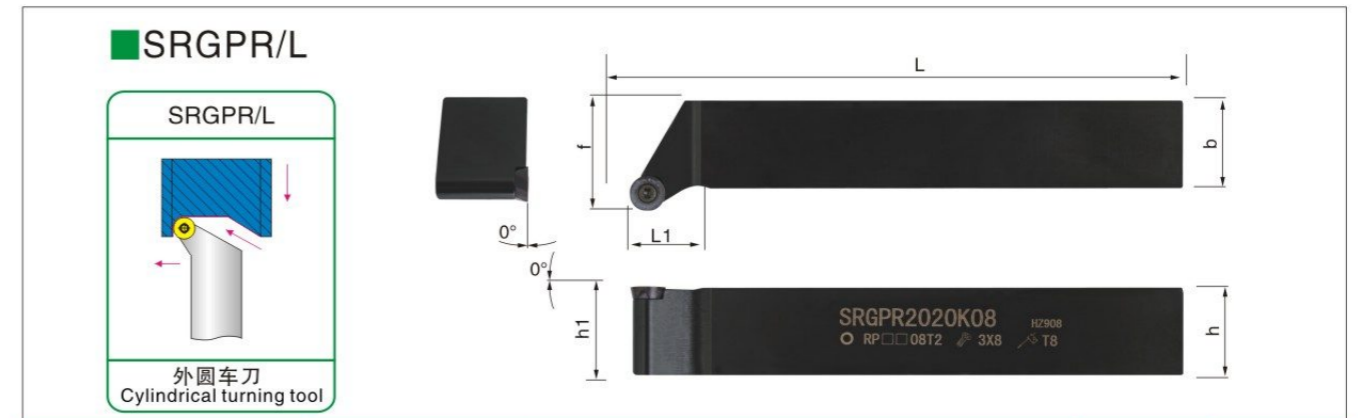

型号 Type	刀片 Blade	规格 Specification						螺丝 Screw	扳手 Wrench
		h	b	L	L1	h1	f		
SRGPR/L1212H05	RP□□0502□□	12	12	100	9.5	12	16	M2.2×6	T6
SRGPR/L1616H05		16	16	100	9.5	16	20		
SRGPR/L2020K05		20	20	125	11.2	20	25		
SRGPR/L2525M05	RP□□0602□□	25	25	150	14.7	25	32	M2.5×6	T8
SRGPR/L1212H06		12	12	100	10	12	16		
SRGPR/L1616H06		16	16	100	10	16	20		
SRGPR/L2020K06	RP□□08T2□□	20	20	125	12	20	25	M3×8	T8
SRGPR/L2525M06		25	25	150	15	25	32		
SRGPR/L1616H08		16	16	100	11	16	20		
SRGPR/L2020K08	RP□□10T3□□	20	20	125	12.7	20	25	M3.5×10	T15
SRGPR/L2525M08		25	25	150	16.2	25	32		
SRGPR/L1616H10		16	16	100	11	16	20		
SRGPR/L2020K10	RP□□1204□□	20	20	125	12.7	20	25	M4×10	
SRGPR/L2525M10		25	25	150	16.2	25	32		
SRGPR/L2020K12		20	20	125	13	20	25		
SRGPR/L2525M12		25	25	150	17	25	32		

▲更多型号可咨询，可接受高要求非标定制

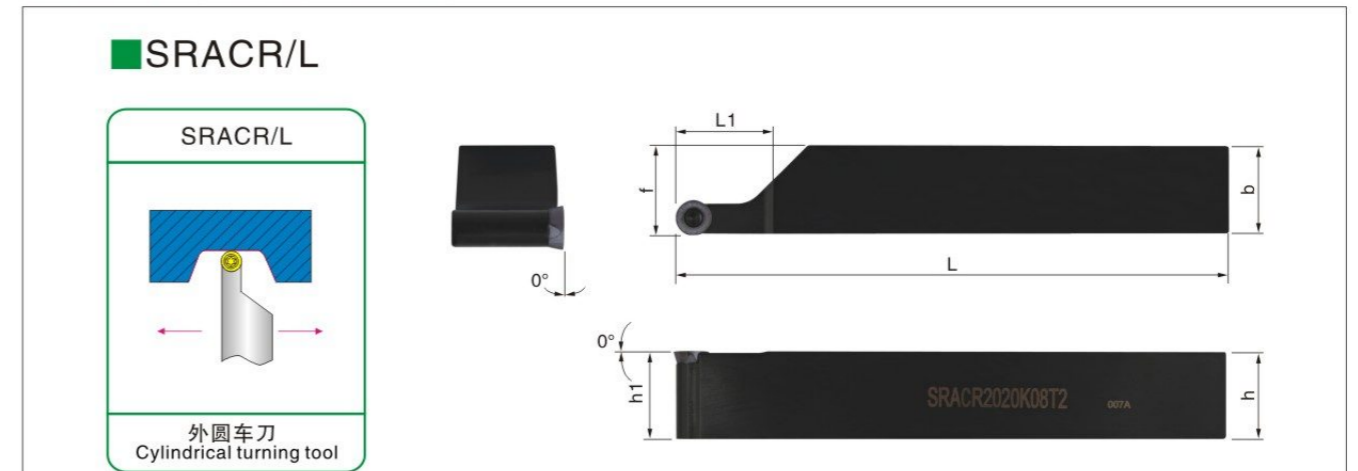

型号 Type	刀片 Blade	规格 Specification						螺丝 Screw	扳手 Wrench
		h	b	L	L1	h1	f		
SRACR/L1616H08	RC□□0803□□	16	16	100	16	16	16.5	M3×8	T8
SRACR/L2020K08		20	20	125	16	20	20.5		
SRACR/L2525M08		25	25	150	16	25	25.5		
SRACR/L2020K10	RC□□1003□□	20	20	125	20.3	20	20.6	M3.5×10	T15
SRACR/L2525M10		25	25	150	20.3	25	25.6		
SRACR/L2020K12		20	20	125	25	20	20.8		
SRACR/L2525M12	RC□□1204□□	25	25	150	25	25	25.8	M3.5×10	

▲更多型号可咨询，可接受高要求非标定制

SRGCR/L

SRGCR/L
外圆车刀
Cylindrical turning tool

型号	刀片 Blade	规格 Specification						螺丝 Screw	扳手 Wrench
		h	b	L	L1	h1	f		
SRGCR/L1212H06	RC□□0602□□	12	12	100	10	12	16	M2.5×6	T8
SRGCR/L1616H06		16	16	100	10	16	20		
SRGCR/L2020K06		20	20	125	12	20	25		
SRGCR/L2525M06	RC□□0803□□	25	25	150	15	25	32	M3×8	
SRGCR/L1616H08		16	16	100	11	16	20		
SRGCR/L2020K08		20	20	125	12.7	20	25		
SRGCR/L2525M08	RC□□1003□□	25	25	150	16.2	25	32	M3.5×10	T15
SRGCR/L1616H10		16	16	100	11	16	20		
SRGCR/L2020K10		20	20	125	12.7	20	25		
SRGCR/L2525M10	RC□□1204□□	25	25	150	16.2	25	32	M3.5×10	
SRGCR/L2020K12		20	20	125	13	20	25		
SRGCR/L2525M12		25	25	150	17	25	32		

▲更多型号可咨询，可接受高要求非标定制

GTTR/L

GTTR/L
外圆车刀
Cylindrical turning tool

型号 Type	刀片 Blade	规格 Specification						螺丝 Screw	扳手 Wrench
		b	h	L	h1	f	Tmax		
GTTR/L08F00	GTM□32R/L□□	8	8	80	8	8	2/3	M4×10	T15
GTTR/L10F00		10	10	80	10	10	2/3		
GTTR/L12F00		12	12	100	12	12	2/3		
GTTR/L16F00		16	16	100	16	16	2/3		
GTTR/L20F00		20	20	120	20	20	2/3		

▲更多型号可咨询，可接受高要求非标定制

HAOR

HAOR
外圆车刀
Cylindrical turning tool

型号 Type	刀片 Blade	规格 Specification					螺丝 Screw	扳手 Wrench
		b	h	L	h1	f		
HAOR07	HAOF HAOB HAOC HAOG	7	7	120	7.9	7	M2.5×7	T8
HAOR08		8	8	120	8.9	8		
HAOR095		9.5	9.5	120	10.4	9.5		
HAOR10		10	10	120	10.9	10		
HAOR12		12	12	120	12.9	12		

▲更多型号可咨询，可接受高要求非标定制

SVNR

SVNR
外圆车刀
Cylindrical turning tool

型号 Type	刀片 Blade	规格 Specification					螺丝 Screw	扳手 Wrench
		b	h	L	h1	f		
SVNR1010H-12N	VNB□R□□	10	10	100	10	10	M3×8	T8
SVNR1212X-12N		12	12	120	12	12		
SVNR1616X-12N		16	16	120	16	16		
SVNR2020X-12N		20	20	120	20	20		
SVNR2525M-12N		25	25	150	25	25		

▲更多型号可咨询，可接受高要求非标定制

SVNR

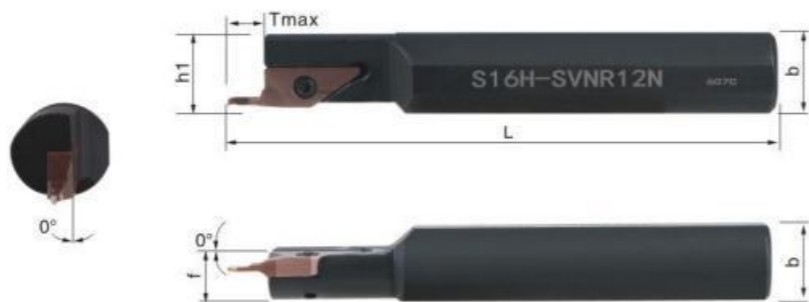
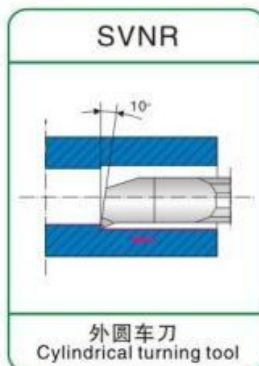

型号 Type	刀片 Blade	规格 Specification					螺丝 Screw	扳手 Wrench
		ϕd	L	L1	H	F		
S12F-SVNR12N	VNB□R□□	12	80	23	11	4.3	M3×8	T8
S14G-SVNR12N		14	90	23	13	4.3		
S16H-SVNR12N		16	100	24	14.8	6.3		
S19H-SVNR12N		19	100	24	17.8	6.3		
S20H-SVNR12N		20	100	24	18.4	6.3		
S25H-SVNR12N		25	100	24	23.4	6.3		

▲更多型号可咨询，可接受高要求非标定制

CKBR

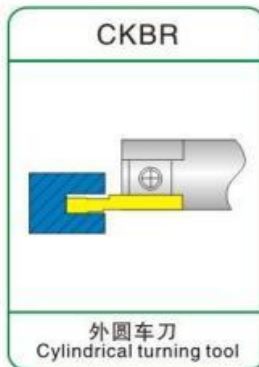

型号 Type	刀片 Blade	规格 Specification					螺丝 Screw	扳手 Wrench
		b	h	L	h1	f		
CKBR1010-16	KBMFR06□□	10	10	100	10	10	M5×15	L4
CKBR1212-16		12	12	100	12	12		
CKBR1616-16		16	16	100	16	16		
CKBR2020-16		20	20	125	20	20		
CKBR2525-16		25	25	125	25	25		

▲更多型号可咨询，可接受高要求非标定制



内孔车刀系列

Internal turning tool

www.wencerl.com

切刃角 Cut-in angle				
A	B	C	D	E
F	G	H	I	J
K	L	M	N	O
P	Q	R	S	T
U	V	W	X	Y
Z				

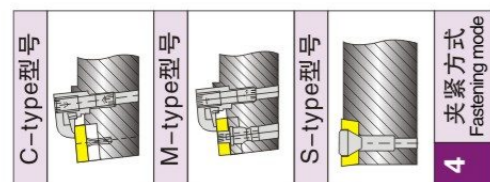

4 夹紧方式
Fastening mode

- 1 **S**
- 2 **25**
- 3 **R**
- 4 **M**
- 5 **C**
- 6 **L**
- 7 **N**
- 8 **R**
- 9 **12**

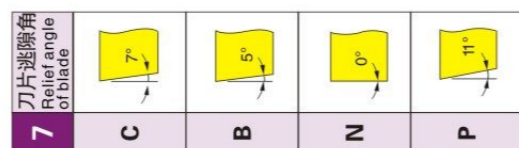
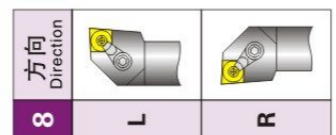
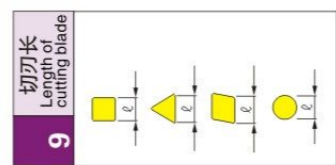

5	刀片形状 Shape of blade
C	四边形 顶角80° Quadrangle Vertex angle 80°
D	四边形 顶角55° Quadrangle Vertex angle 55°
K	平行四边形 顶角55° Parallelogram Vertex angle 55°
R	圆形 Round
S	正方形 Square
T	正三角形 Regular triangle
V	四边形 顶角35° Quadrangle Vertex angle 35°
W	特殊六角形 Special hexagon

3	长度 Length (mm)
H	100
K	125
M	150
N	160
Q	180
R	200
S	250
T	300
U	350
V	400
W	450
Y	500



1	材质 Material
C	碳化钨 Tungsten carbide
H	高速钢 High speed steel
S	合金钢 Alloy steel

MCLNR/L

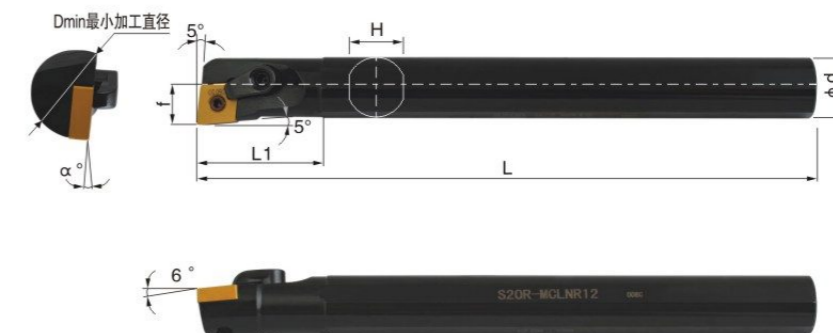
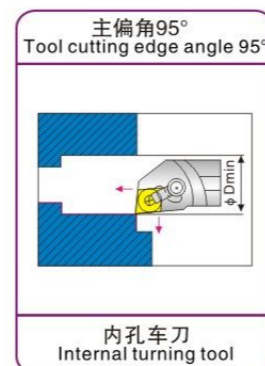

型号 Type	刀片 Blade	规格 Specification							刀垫 Shim	销钉 Pin	压板 Clamp	双头螺丝 Screw	扳手 Wrench
S16Q-MCLNR/L12	CN□□1204□□	φ Dmin	φ d	L	L1	H	f	α°	MC1204	CTM617	HL1813	ML0625	L3.0
S20R-MCLNR/L12		20	16	180	35	14.8	11	18°					
S25S-MCLNR/L12		25	20	200	45	19	13	15°					
S32T-MCLNR/L12		29	25	250	45	24	15	12°					
S40T-MCLNR/L12		38	32	300	50	30	20.5	17°					
S32T-MCLNR/L16		44	40	300	55	38	24	15°					
S40T-MCLNR/L16	48	40	300	55	38	26	15°	MC1604	CTM822	HL2217	ML0830	L3.0 L4.0	

型号 Type	刀片 Blade	规格 Specification							刀垫 Shim	压板螺钉 Plate screws	压板 Clamp	弹簧 Spring	刀垫螺钉 Shim screw	扳手 Wrench
S20R-DCLNR/L12	CN□□1204□□	φ Dmin	φ d	L	L1	H	f	α°	MC1204	M6×21	HLD-1	TH810	M6×9P	L3.0
S25S-DCLNR/L12		25	20	200	45	19	13	15°						
S32T-DCLNR/L12		29	25	250	45	24	15	12°						
S40T-DCLNR/L12		38	32	300	50	30	20.5	17°						

型号 Type	刀片 Blade	规格 Specification							刀垫 Shim	销钉 Pin	压板 Clamp	螺钉 Screw	塞环 Sloper ring	扳手 Wrench
S32T-ZCLNR/L16	CN□□1606□□	φ Dmin	φ d	L	L1	H	f	α°	MC1204	CT618-Z	HLZ-C	M8×25	ZCM6	L3.0 L4.0
S40T-ZCLNR/L16		40	32	300	50	30	22.5	17°						
S40T-ZCLNR/L16	48	40	300	55	38	26	15°							

▲更多型号可咨询，可接受高要求非标定制

MCKNR/L

主偏角75°
Tool cutting edge angle 75°

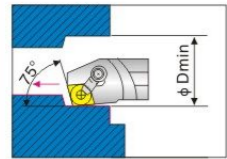

内孔车刀
Internal turning tool

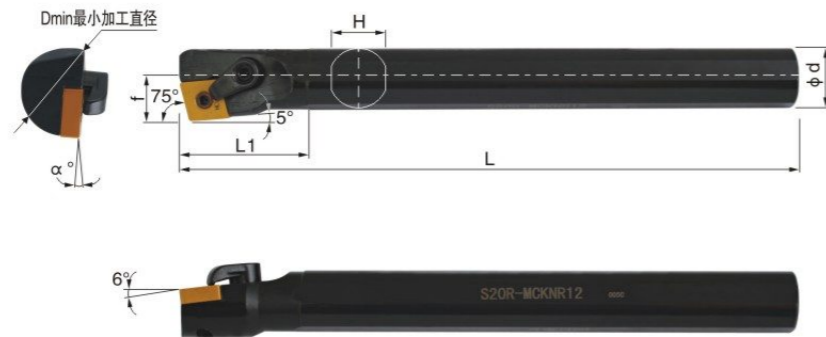

型号 Type	刀片 Blade	规格 Specification							刀垫 Shim	销钉 Pin	压板 Clamp	双头螺丝 Screw	扳手 Wrench
		φDmin	φd	L	L1	H	f	α°					
S20R-MCKNR/L12	CN□□1204□□	25	20	200	45	19	13	15°	/	CTM613	HL1810	ML0620	L3.0
S25S-MCKNR/L12		30	25	250	45	24	15.5	12°					
S32T-MCKNR/L12		38	32	300	50	30	20.5	17°	MC1204	CTM617	HL1813	ML0625	L3.0
S40T-MCKNR/L12		46	40	300	55	38	24	15°					

型号 Type	刀片 Blade	规格 Specification							刀垫 Shim	压板螺钉 Plate screws	压板 Clamp	弹簧 Spring	刀垫螺钉 Shim screw	扳手 Wrench
		φDmin	φd	L	L1	H	f	α°						
S20R-DCKNR/L12	CN□□1204□□	25	20	200	45	19	13	15°	/	M6×21	HLD-1	TH810	/	L3.0
S25S-DCKNR/L12		30	25	250	45	24	15.5	12°						
S32T-DCKNR/L12		38	32	300	50	30	20.5	17°	MC1204	/	/	M6×9P	/	
S40T-DCKNR/L12		46	40	300	55	38	24	15°						

型号 Type	刀片 Blade	规格 Specification							刀垫 Shim	销钉 Pin	压板 Clamp	螺钉 Screw	塞环 Sloper ring	扳手 Wrench
		φDmin	φd	L	L1	H	f	α°						
S32T-ZCKNR/L12	CN□□1204□□	38	32	300	50	30	20.5	17°	MC1204	CT618-Z	HLZ-CB	M8×25	ZCM6	L3.0 L4.0
S40T-ZCKNR/L12		46	40	300	55	38	24	15°						

▲更多型号可咨询，可接受高要求非标定制

MCWNR/L

主偏角50°
Tool cutting edge angle 50°

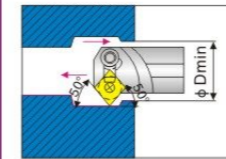

内孔车刀
Internal turning tool

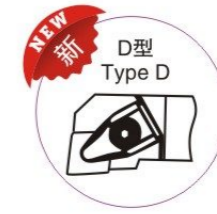
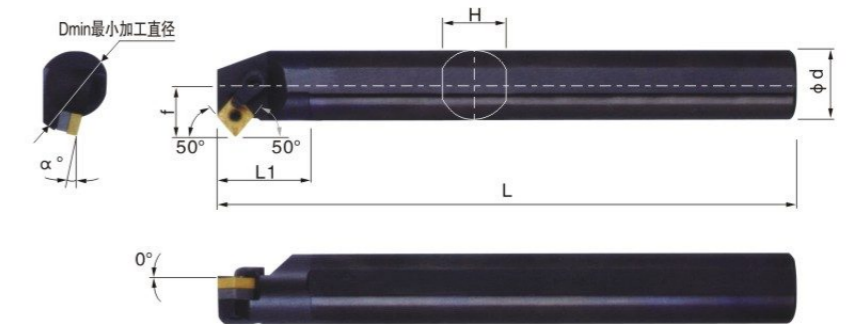

型号 Type	刀片 Blade	规格 Specification							刀垫 Shim	销钉 Pin	压板 Clamp	双头螺丝 Screw	扳手 Wrench
		φDmin	φd	L	L1	H	f	α°					
S20R-MCWNR/L12	CN□□1204□□	30	20	200	45	19	17	15°	/	CTM613	HL1810	ML0620	L3.0
S25S-MCWNR/L12		35	25	250	45	24	19.5	12°					
S32T-MCWNR/L12		42	32	300	50	30	23.5	17°	MC1204	CTM617	HL1813	ML0625	L3.0
S40T-MCWNR/L12		50	40	300	55	38	27	15°					

型号 Type	刀片 Blade	规格 Specification							刀垫 Shim	压板螺钉 Plate screws	压板 Clamp	弹簧 Spring	刀垫螺钉 Shim screw	扳手 Wrench
		φDmin	φd	L	L1	H	f	α°						
S20R-DCWNR/L12	CN□□1204□□	30	20	200	45	19	17	15°	/	M6×21	HLD-1	TH810	/	L3.0
S25S-DCWNR/L12		35	25	250	45	24	19.5	12°						
S32T-DCWNR/L12		42	32	300	50	30	23.5	17°	MC1204	/	/	M6×9P	/	
S40T-DCWNR/L12		50	40	300	55	38	27	15°						

▲更多型号可咨询，可接受高要求非标定制

MTJNR/L

主偏角93°
Tool cutting edge angle 93°

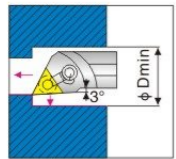

内孔车刀
Internal turning tool

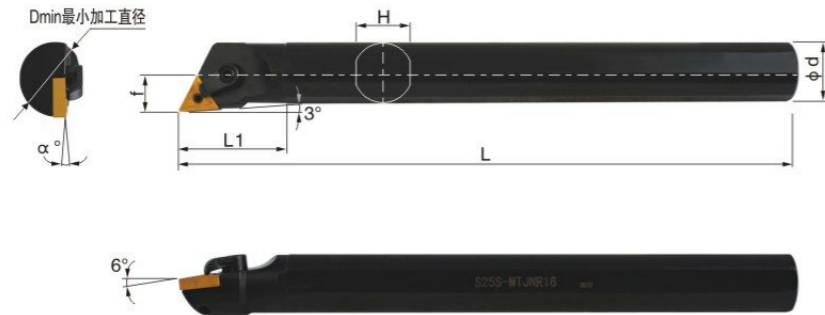

型号 Type	刀片 Blade	规格 Specification							刀垫 Shim	销钉 Pin	压板 Clamp	双头螺丝 Screw	扳手 Wrench
		ϕ Dmin	ϕ d	L	L1	H	f	α°					
S20R-MTJNR/L16	TN□□1604□□	24	20	200	40	19	12.5	15°	/	CTM511	HL1810	ML0620	L2.0 L3.0
S25S-MTJNR/L16		30	25	250	45	24	16	12°					
S32T-MTJNR/L16		37	32	300	54	30	19.5	17°					

▲更多型号可咨询，可接受高要求非标定制

MTFNR/L

主偏角91°
Tool cutting edge angle 91°

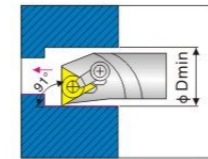

内孔车刀
Internal turning tool

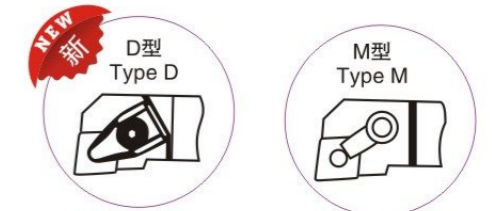
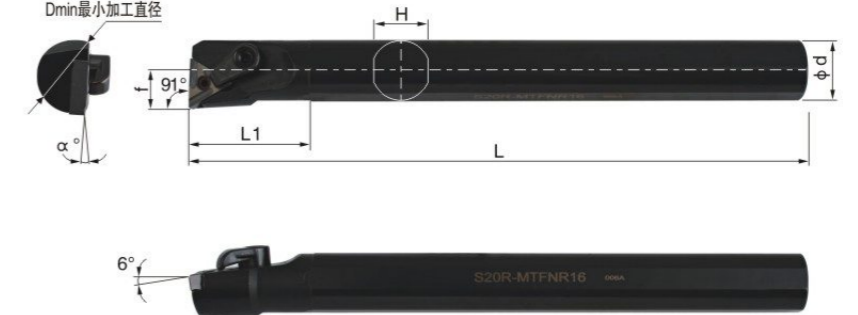

型号 Type	刀片 Blade	规格 Specification							刀垫 Shim	销钉 Pin	压板 Clamp	双头螺丝 Screw	扳手 Wrench					
		ϕ Dmin	ϕ d	L	L1	H	f	α°										
S16Q-MTFNR/L16	TN□□1604□□	20	16	180	35	15	11	15°	/	CTM511	HL1810	ML0620	L2.0 L3.0					
S18Q-MTFNR/L16		22	18	180	35	17	12	15°										
S20R-MTFNR/L16		25	20	200	40	19	13	15°										
S25S-MTFNR/L16		30	25	250	45	24	15.5	12°										
S32T-MTFNR/L16		38	32	300	54	30	20.5	17°						MT1603	CTM513	HL1813	ML0625	L2.0 L3.0
S40T-MTFNR/L16		47	40	300	60	38	25	15°										

型号 Type	刀片 Blade	规格 Specification							刀垫 Shim	压板螺钉 Plate screws	压板 Clamp	弹簧 Spring	刀垫螺钉 Shim screw	扳手 Wrench				
		ϕ Dmin	ϕ d	L	L1	H	f	α°										
S16Q-DTFNR/L16	TN□□1604□□	20	16	180	35	15	11	15°	/	M6×21	HLD-3	TH810	/	L3.0				
S18Q-DTFNR/L16		22	18	180	35	17	12	15°										
S20R-DTFNR/L16		25	20	200	40	19	13	15°										
S25S-DTFNR/L16		30	25	250	45	24	15.5	12°										
S32T-DTFNR/L16		38	32	300	54	30	20.5	17°							MT1603			M5×9P
S40T-DTFNR/L16		47	40	300	60	38	25	15°										

▲更多型号可咨询，可接受高要求非标定制

MTWNR/L

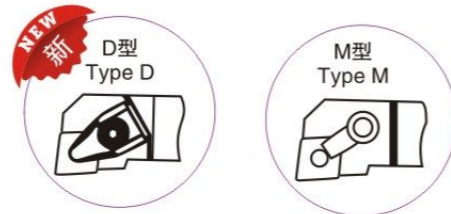
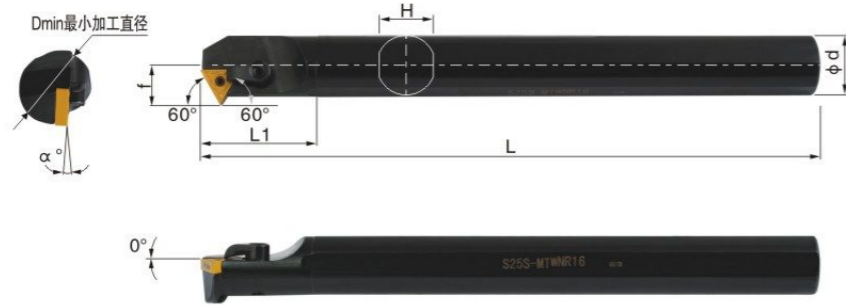
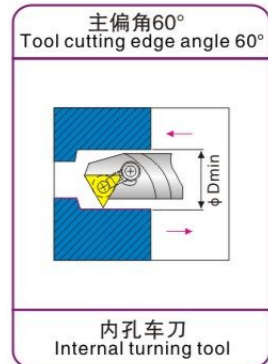

型号 Type	刀片 Blade	规格 Specification							刀垫 Shim	销钉 Pin	压板 Clamp	双头螺丝 Screw	扳手 Wrench
		φ Dmin	φ d	L	L1	H	f	α°					
S20R-MTWNR/L16	TN □□1604□□	25	20	200	40	19	13.5	15°	/	CTM511	HL1810	ML0620	L2.0 L3.0
S25S-MTWNR/L16		30	25	250	45	24	16.5	12°					
S32T-MTWNR/L16		37	32	300	54	30	20	17°					

型号 Type	刀片 Blade	规格 Specification							刀垫 Shim	压板螺钉 Plate screws	压板 Clamp	弹簧 Spring	刀垫螺钉 Shim screw	扳手 Wrench
		φ Dmin	φ d	L	L1	H	f	α°						
S20R-DTWNR/L16	TN □□1604□□	25	20	200	40	19	13.5	15°	/	M6×21	HLD-3	TH810	/	L3.0
S25S-DTWNR/L16		30	25	250	45	24	16.5	12°						
S32T-DTWNR/L16		37	32	300	54	30	20	17°						

▲更多型号可咨询，可接受高要求非标定制

MTUNR/L

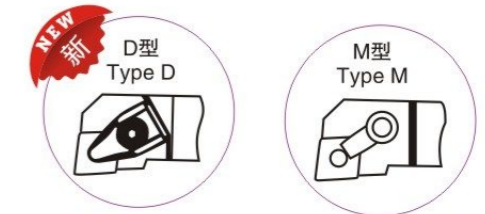
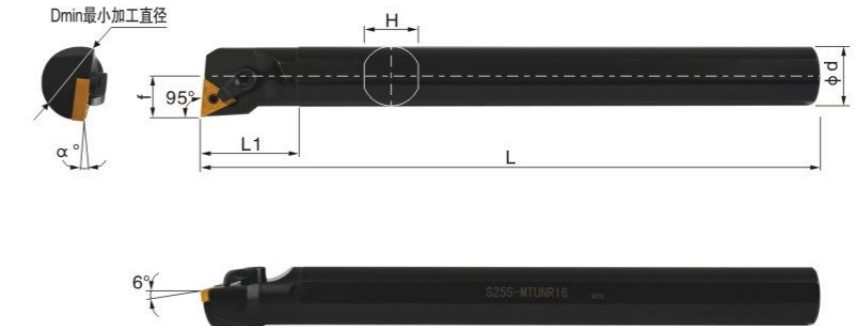
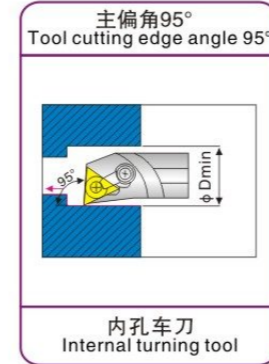

型号 Type	刀片 Blade	规格 Specification							刀垫 Shim	销钉 Pin	压板 Clamp	双头螺丝 Screw	扳手 Wrench					
		φ Dmin	φ d	L	L1	H	f	α°										
S16Q-MTUNR/L16	TN □□1604□□	20	16	180	40	15	11	15°	/	CTM511	HL1810	ML0620	L2.0 L3.0					
S18Q-MTUNR/L16		22	18	180	40	17	12	15°										
S20R-MTUNR/L16		25	20	200	40	13	13.5	15°										
S25S-MTUNR/L16		30	25	250	45	24	15.5	12°										
S32T-MTUNR/L16		38	32	300	54	30	20.5	17°						MT1603	CTM513	HL1813	ML0625	L2.0 L3.0
S40T-MTUNR/L16		47	40	300	60	38	25	15°										

型号 Type	刀片 Blade	规格 Specification							刀垫 Shim	压板螺钉 Plate screws	压板 Clamp	弹簧 Spring	刀垫螺钉 Shim screw	扳手 Wrench				
		φ Dmin	φ d	L	L1	H	f	α°										
S16Q-DTUNR/L16	TN □□1604□□	20	16	180	40	15	11	15°	/	M6×21	HLD-3	TH810	/	L3.0				
S18Q-DTUNR/L16		22	18	180	40	17	12	15°										
S20R-DTUNR/L16		25	20	200	40	13	13.5	15°										
S25S-DTUNR/L16		30	25	250	45	24	15.5	12°										
S32T-DTUNR/L16		38	32	300	54	30	20.5	17°							MT1603	/	/	M5×9P
S40T-DTUNR/L16		47	40	300	60	38	25	15°										

▲更多型号可咨询，可接受高要求非标定制

MTQNR/L

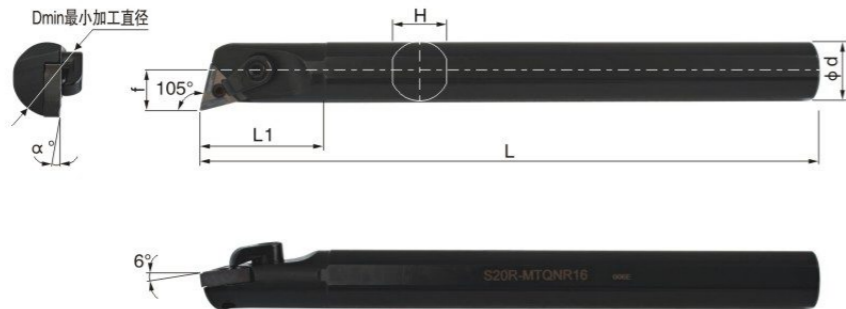
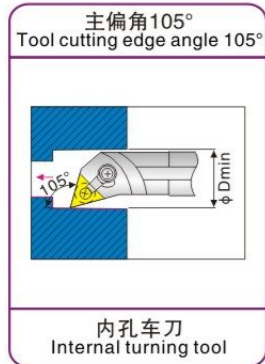

型号 Type	刀片 Blade	规格 Specification							刀垫 Shim	销钉 Pin	压板 Clamp	双头螺丝 Screw	扳手 Wrench
		φ Dmin	φ d	L	L1	H	f	α°					
S18Q-MTQNR/L16	TN□□1604□□	21	18	180	40	17	11.5	15°	/	CTM511	HL1810	ML0620	L2.0
S20R-MTQNR/L16		24	20	200	40	19	12.5	15°					L3.0
S25S-MTQNR/L16		30	25	250	45	24	16	12°	MT1603	CTM513	HL1813	ML0625	L2.0
S32T-MTQNR/L16		38	32	300	54	30	20.5	17°					L3.0
S40T-MTQNR/L16		48	40	300	60	38	26	15°					L3.0

▲更多型号可咨询, 可接受高要求非标定制

MTLNR/L

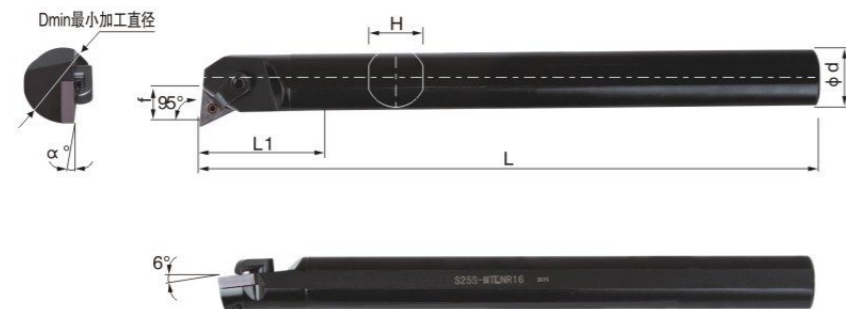
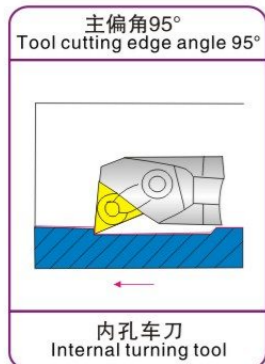

型号 Type	刀片 Blade	规格 Specification							刀垫 Shim	销钉 Pin	压板 Clamp	双头螺丝 Screw	扳手 Wrench
		φ Dmin	φ d	L	L1	H	f	α°					
S18Q-MTLNR/L16	TN□□1604□□	22	18	180	36	17	12.5	15°	/	CTM511	HL1810	ML0620	L2.0
S20R-MTLNR/L16		25	20	200	37	19	13.5	15°					L3.0
S25S-MTLNR/L16		30	25	250	45	23	17	12°	MT1603	CTM513	HL1813	ML0625	L2.0
S32T-MTLNR/L16		37	32	300	50	30	21	17°					L3.0

▲更多型号可咨询, 可接受高要求非标定制

MSKNR/L

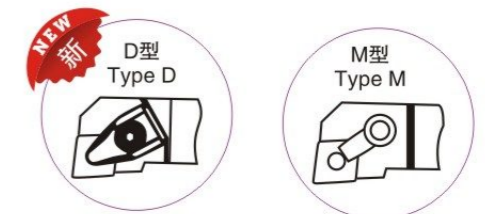
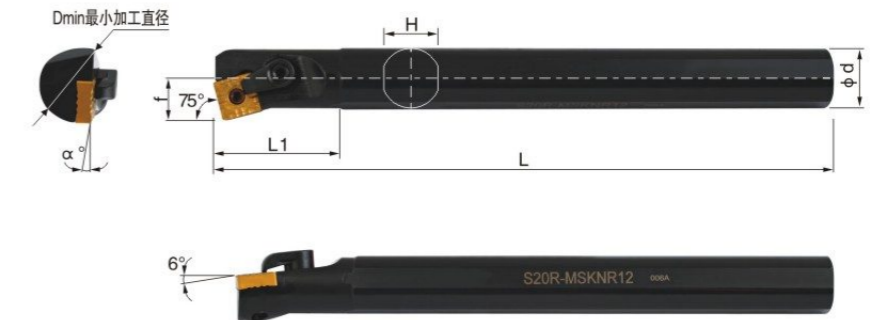
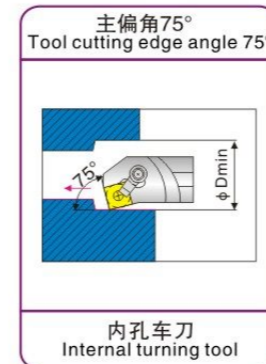

型号 Type	刀片 Blade	规格 Specification							刀垫 Shim	销钉 Pin	压板 Clamp	双头螺丝 Screw	扳手 Wrench
		φ Dmin	φ d	L	L1	H	f	α°					
S20R-MSKNR/L12	SN□□1204□□	26	20	200	40	19	14	15°	/	CTM613	HL1810	ML0620	L3.0
S25S-MSKNR/L12		30	25	250	45	24	16.1	12°					
S32T-MSKNR/L12		40	32	300	50	30	22	17°	MS1204	CTM617	HL1813	ML0625	L3.0
S40T-MSKNR/L12		48	40	300	55	38	27	15°					
S50U-MSKNR/L12		60	50	350	65	48	30	12°					

型号 Type	刀片 Blade	规格 Specification							刀垫 Shim	压板螺钉 Plate screws	压板 Clamp	弹簧 Spring	刀垫螺钉 Shim screw	扳手 Wrench
		φ Dmin	φ d	L	L1	H	f	α°						
S20R-DSKNR/L12	SN□□1204□□	26	20	200	40	19	14	15°	/	M6×21	HLD-1	TH810	/	L3.0
S25S-DSKNR/L12		30	25	250	45	24	16.1	12°						
S32T-DSKNR/L12		40	32	300	50	30	22	17°	MS1204	/	/	M6×9P	L3.0	
S40T-DSKNR/L12		48	40	300	55	38	27	15°						
S50U-DSKNR/L12		60	50	350	65	48	30	12°						

▲更多型号可咨询, 可接受高要求非标定制

MSSNR/L

主偏角45°
Tool cutting edge angle 45°

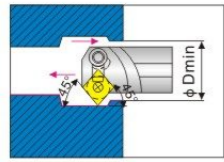

内孔车刀
Internal turning tool

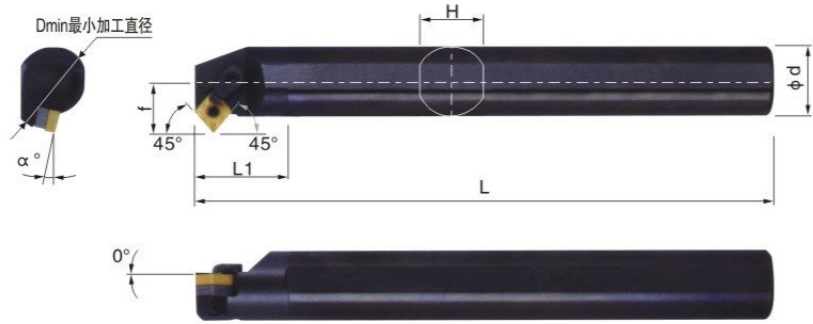

型号 Type	刀片 Blade	规格 Specification							刀垫 Shim	销钉 Pin	压板 Clamp	双头螺丝 Screw	扳手 Wrench
		φ Dmin	φ d	L	L1	H	f	α°					
S20R-MSSNR/L12	SN□□1204□□	27	20	200	35	19	15.5	15°	/	CTM613	HL1810	ML0620	L3.0
S25S-MSSNR/L12		30	25	250	40	23	17	12°					
S32T-MSSNR/L12		38	32	300	45	30	21	17°					

▲更多型号可咨询, 可接受高要求非标定制

MDQNR/L

主偏角107.5°
Tool cutting edge angle 107.5°

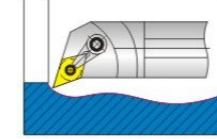

内孔车刀
Internal turning tool

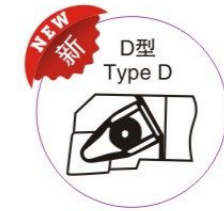
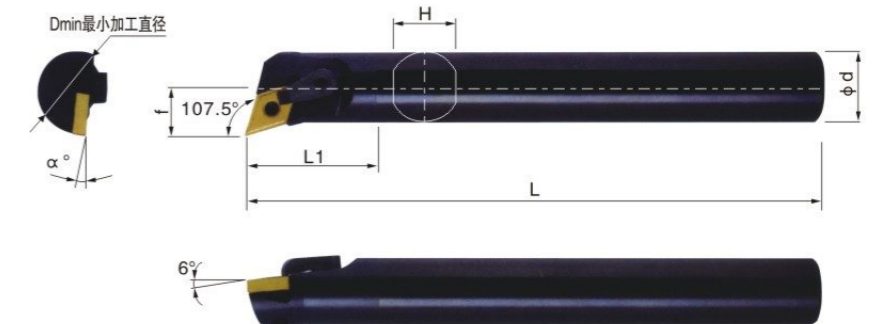

型号 Type	刀片 Blade	规格 Specification							刀垫 Shim	销钉 Pin	压板 Clamp	双头螺丝 Screw	扳手 Wrench
		φ Dmin	φ d	L	L1	H	f	α°					
S20R-MDQNR/L11	DN□□1104□□	25	20	200	40	18.5	14.5	15°	/	CTM511	HL1810	ML0625	L2.0 L3.0
S25S-MDQNR/L15	DN□□1504□□	31	25	250	45	24	17	12°	/	CTM613	HL2114	ML0625	L3.0
S32T-MDQNR/L15		38	32	300	50	30	20.5	17°	MD1506	CTM619	HL2114	ML0625	L3.0
S40T-MDQNR/L15		50	40	300	60	38	27	15°					

型号 Type	刀片 Blade	规格 Specification							刀垫 Shim	压板螺钉 Plate screws	压板 Clamp	弹簧 Spring	刀垫螺钉 Shim screw	扳手 Wrench	
		φ Dmin	φ d	L	L1	H	f	α°							
S20R-DDQNR/L11	DN□□1104□□	25	20	200	40	18.5	14.5	15°	/	M6×21	HLD-3	TH810	/	L3.0	
S25S-DDQNR/L15	DN□□1504□□	31	25	250	45	24	17	12°	/				/		
S32T-DDQNR/L15		38	32	300	50	30	20.5	17°	MD1504				HLD-2		M6×9P
S40T-DDQNR/L15		50	40	300	60	38	27	15°							

▲更多型号可咨询, 可接受高要求非标定制

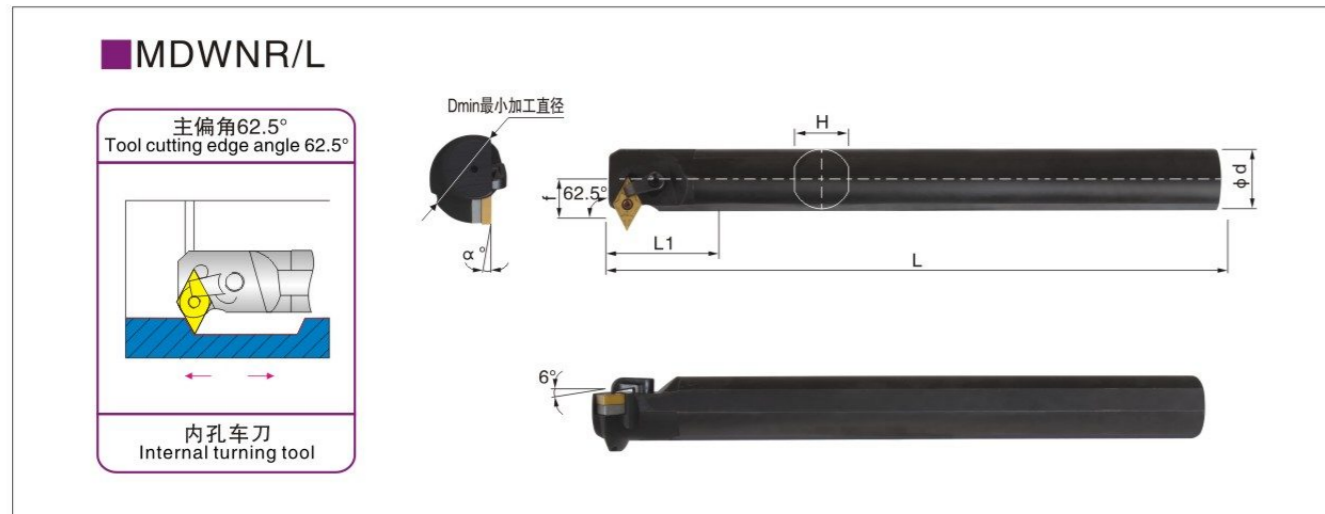

型号 Type	刀片 Blade	规格 Specification							刀垫 Shim	销钉 Pin	压板 Clamp	双头螺丝 Screw	扳手 Wrench
		φ Dmin	φ d	L	L1	H	f	α°					
S20R-MDWNR/L11	DN□□1104□□	28	20	200	36	19	16	15°		CTM511	HL1810	ML0620	L2.0,L3.0
S25S-MDWNR/L15		37	25	250	45	23	22.5	12°		CTM613	HL2113		
S32T-MDWNR/L15	DN□□1504□□	45	32	300	50	30	27	15°	MD1504	CTM617	HL2113	ML0625	L3.0
S40T-MDWNR/L15		53	40	300	55	38	31	15°	MD1506	CTM619	HL2113		

▲更多型号可咨询，可接受高要求非标定制

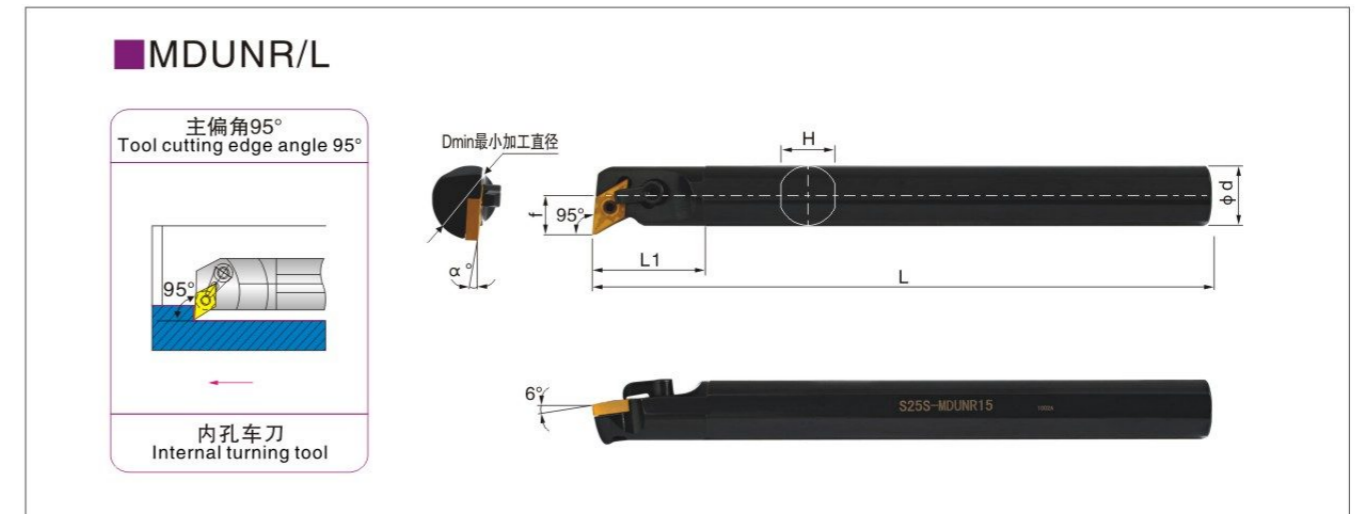

型号 Type	刀片 Blade	规格 Specification							刀垫 Shim	销钉 Pin	压板 Clamp	双头螺丝 Screw	扳手 Wrench
		φ Dmin	φ d	L	L1	H	f	α°					
S20R-MDUNR/L11	DN□□1104□□	26	20	200	40	18.4	14.5	15°		CTM511	HL1810	ML0620	L2.0 L3.0
S25S-MDUNR/L15		30	25	250	45	24	16	12°		CTM613	HL2114	ML0625	L3.0
S32T-MDUNR/L15	DN□□1504□□	38	32	300	50	30	21	17°	MD1506	CTM619	HL2114	ML0625	L3.0
S40T-MDUNR/L15		48	40	300	60	38	26	15°					

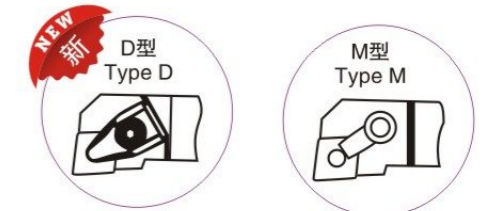

型号 Type	刀片 Blade	规格 Specification							刀垫 Shim	压板螺钉 Plate screws	压板 Clamp	弹簧 Spring	刀垫螺钉 Shim screw	扳手 Wrench
		φ Dmin	φ d	L	L1	H	f	α°						
S25S-DDUNR/L15		30	25	250	45	24	16	12°						
S32T-DDUNR/L15	DN□□1504□□	38	32	300	50	30	21	17°	MD1506	M6×21	HLD-2	TH810		L3.0
S40T-DDUNR/L15		48	40	300	60	38	26	15°						

型号 Type	刀片 Blade	规格 Specification							刀垫 Shim	压板螺钉 Plate screws	压板 Clamp	弹簧 Spring	刀垫螺钉 Shim screw	扳手 Wrench
		φ Dmin	φ d	L	L1	H	f	α°						
S25S-DDUNR/L15		30	25	250	45	24	16	12°						
S32T-DDUNR/L15	DN□□1504□□	38	32	300	50	30	21	17°	MD1506	M6×21	HLD-2	TH810		L3.0
S40T-DDUNR/L15		48	40	300	60	38	26	15°						

▲更多型号可咨询，可接受高要求非标定制

MDZNR/L

主偏角93°
Tool cutting edge angle 93°

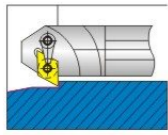

内孔车刀
Internal turning tool

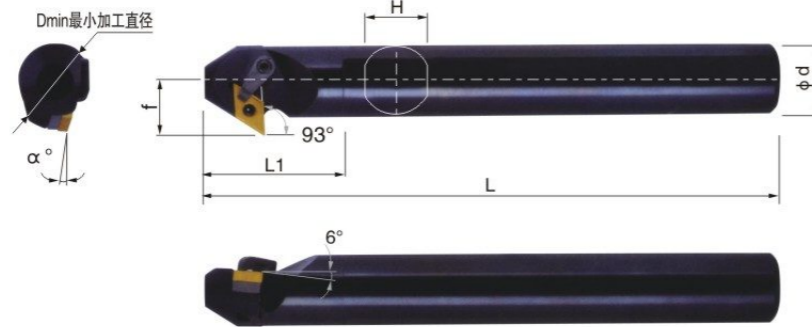

型号 Type	刀片 Blade	规格 Specification							刀垫 Shim	销钉 Pin	压板 Clamp	双头螺丝 Screw	扳手 Wrench
		phi Dmin	phi d	L	L1	H	f	alpha °					
S25S-MDZNR/L15	DN□□1504□□	35	25	250	46	23.4	20.5	15°	MD1506	CTM613	HL2114	ML0625	L3.0
S32T-MDZNR/L15		40	32	300	50	30	23	17°					
S40T-MDZNR/L15		50	40	300	55	38	27	15°					

▲更多型号可咨询, 可接受高要求非标定制

MVQNR/L

主偏角117.5°
Tool cutting edge angle 117.5°

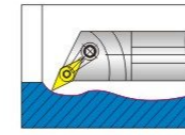

内孔车刀
Internal turning tool

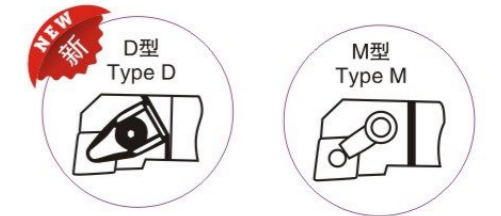
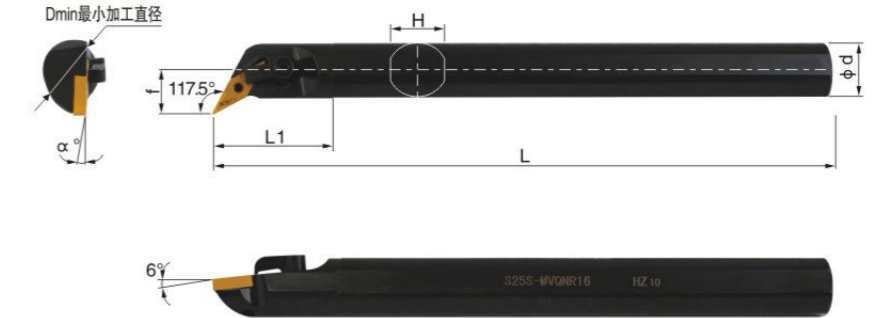

型号 Type	刀片 Blade	规格 Specification							刀垫 Shim	销钉 Pin	压板 Clamp	双头螺丝 Screw	扳手 Wrench
		phi Dmin	phi d	L	L1	H	f	alpha °					
S20R-MVQNR/L16	VN□□1604□□	28	20	200	45	18.5	16	15°	MV1603	CTM513	HL2114	ML0625	L2.0 L3.0
S25S-MVQNR/L16		31	25	250	45	24	17	12°					
S32T-MVQNR/L16		39	32	300	50	30	23	17°					
S40T-MVQNR/L16		50	40	300	55	38	27	15°					

型号 Type	刀片 Blade	规格 Specification							刀垫 Shim	压板螺钉 Plate screws	压板 Clamp	弹簧 Spring	刀垫螺钉 Shim screw	扳手 Wrench
		phi Dmin	phi d	L	L1	H	f	alpha °						
S20R-DVQNR/L16	VN□□1604□□	28	20	200	45	18.5	16	15°	MV1603	M5×21	HLD-3	TH710	M5×9P	L3.0 L2.5 L3.0
S25S-DVQNR/L16		31	25	250	45	24	17	12°						
S32T-DVQNR/L16		39	32	300	50	30	23	17°						
S40T-DVQNR/L16		50	40	300	55	38	27	15°						

▲更多型号可咨询, 可接受高要求非标定制

MVXNR/L

主偏角96°
Tool cutting edge angle 96°

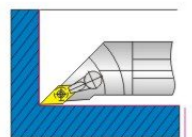

内孔车刀
Internal turning tool

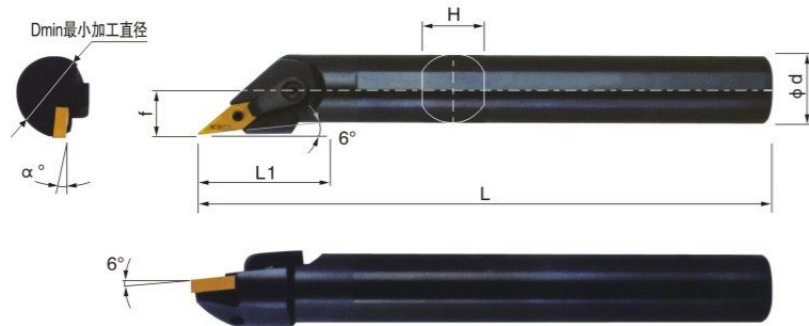

型号 Type	刀片 Blade	规格 Specification							刀垫 Shim	销钉 Pin	压板 Clamp	双头螺丝 Screw	扳手 Wrench
		φ Dmin	φ d	L	L1	H	f	α°					
S20R-MVXNR/L16	VN□□1604□□	27	20	200	40	19	14	15	/	CTM511	HL2414	ML0625	L2.0 L3.0
S25S-MVXNR/L16		32	25	250	45	24	17	12					
S32T-MVXNR/L16		42	32	300	50	30	23	17	MV1603	CTM513	HL2414	ML0625	L2.0 L3.0
S40T-MVXNR/L16		50	40	300	55	38	27	15					

型号 Type	刀片 Blade	规格 Specification							刀垫 Shim	压板螺钉 Plate screws	压板 Clamp	弹簧 Spring	刀垫螺钉 Shim screw	扳手 Wrench
		φ Dmin	φ d	L	L1	H	f	α°						
S20R-DVXNR/L16	VN□□1604□□	27	20	200	40	19	14	15	/	M6×21	HLD-4	TH810	/	L3.0
S25S-DVXNR/L16		32	25	250	45	24	17	12						
S32T-DVXNR/L16		42	32	300	50	30	23	17	MV1603				M5×9P	
S40T-DVXNR/L16		50	40	300	55	38	27	15						

型号 Type	刀片 Blade	规格 Specification							刀垫 Shim	销钉 Pin	压板 Clamp	螺钉 Screw	塞环 Sloper ring	扳手 Wrench
		φ Dmin	φ d	L	L1	H	f	α°						
S32T-ZVXNR/L16	VN□□1604□□	42	32	300	50	30	23	17	MV1603	CT515-Z	HLZ-V	M8×25	ZCM6	L2.5 L4.0
S40T-ZVXNR/L16		50	40	300	55	38	27	15						

▲更多型号可咨询，可接受高要求非标定制

MVUNR/L

主偏角95°
Tool cutting edge angle 95°

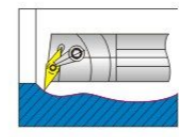

内孔车刀
Internal turning tool

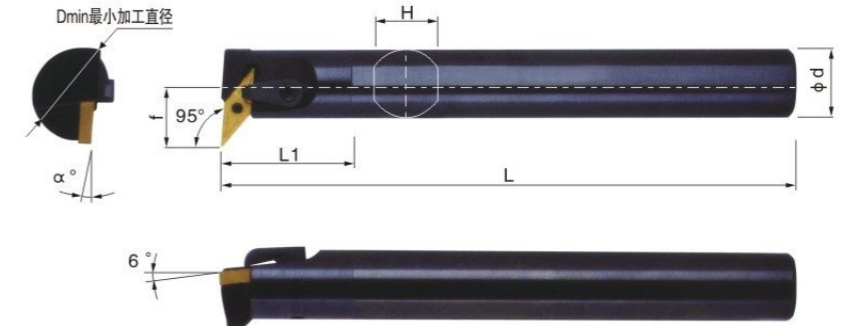

型号 Type	刀片 Blade	规格 Specification							刀垫 Shim	销钉 Pin	压板 Clamp	双头螺丝 Screw	扳手 Wrench
		φ Dmin	φ d	L	L1	H	f	α°					
S20R-MVUNR/L16	VN□□1604□□	32	20	200	40	18.5	20	15°	/	CTM511	HL2114	ML0625	L2.0 L3.0
S25S-MVUNR/L16		34	25	250	45	24	20	12°					
S32T-MVUNR/L16		40	32	300	50	30	22	17°	MV1603	CTM513	HL2114	ML0625	L2.0 L3.0
S40T-MVUNR/L16		48	40	300	55	38	26	15°					

型号 Type	刀片 Blade	规格 Specification							刀垫 Shim	压板螺钉 Plate screws	压板 Clamp	弹簧 Spring	刀垫螺钉 Shim screw	扳手 Wrench
		φ Dmin	φ d	L	L1	H	f	α°						
S20R-DVUNR/L16	VN□□1604□□	32	20	200	40	18.5	20	15°	/	M6×21	HLD-3	TH810	/	L3.0
S25S-DVUNR/L16		34	25	250	45	24	20	12°						
S32T-DVUNR/L16		40	32	300	50	30	22	17°	MV1603				M5×9P	
S40T-DVUNR/L16		48	40	300	55	38	26	15°						

▲更多型号可咨询，可接受高要求非标定制

MVWNR/L

主偏角72.5°
Tool cutting edge angle 72.5°

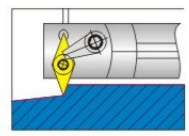

内孔车刀
Internal turning tool



型号 Type	刀片 Blade	规格 Specification							刀垫 Shim	销钉 Pin	压板 Clamp	双头螺丝 Screw	扳手 Wrench
		ϕ Dmin	ϕ d	L	L1	H	f	α°					
S25S-MVWNR/L16	VN□□1604□□	40	25	200	45	24	26	12	/	CTM511	HL2114	ML0620	L2.0 L3.0
S32T-MVWNR/L16		48	32	250	50	30	30	17					

▲更多型号可咨询，可接受高要求非标定制

MVZNR/L

主偏角93°
Tool cutting edge angle 93°

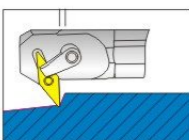

内孔车刀
Internal turning tool

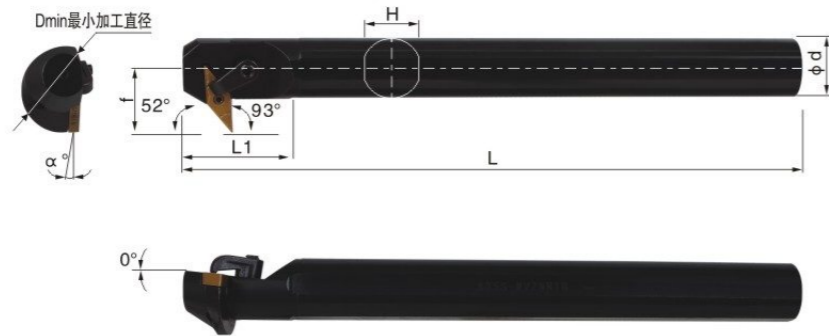

型号 Type	刀片 Blade	规格 Specification							刀垫 Shim	销钉 Pin	压板 Clamp	双头螺丝 Screw	扳手 Wrench
		ϕ Dmin	ϕ d	L	L1	H	f	α°					
S25S-MVZNR/L16	VN□□1604□□	40	25	250	45	23	26	12°	/	CTM511	HL2114	ML0625	L2.0 L3.0
S32T-MVZNR/L16		48	32	300	45	30	30	17°					

▲更多型号可咨询，可接受高要求非标定制

MWLNR/L

主偏角95°
Tool cutting edge angle 95°

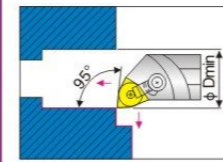

内孔车刀
Internal turning tool

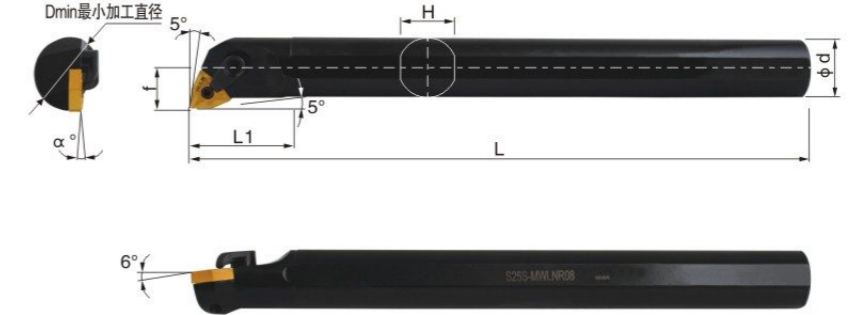

型号 Type	刀片 Blade	规格 Specification							刀垫 Shim	销钉 Pin	压板 Clamp	双头螺丝 Screw	扳手 Wrench						
		ϕ Dmin	ϕ d	L	L1	H	f	α°											
S16Q-MWLNR/L06	WN□□0604□□	20	16	180	35	15	11.0	18°	/	CTM511	HL1511	ML0520	L2.0						
S18Q-MWLNR/L06		22	18	180	35	17	12.0	15°											
S20R-MWLNR/L06		24	20	200	40	19	13.0	15°											
S25S-MWLNR/L06		32	25	250	45	23	17.0	12°											
S32T-MWLNR/L06		40	32	300	50	30	22.0	17°											
S40T-MWLNR/L06		50	40	300	60	37	27.0	15°											
S16Q-MWLNR/L08		WN□□0804□□	20	16	180	35	15	11						15°	/	CTM613	HL1810	ML0620	L3.0
S18Q-MWLNR/L08			22	18	180	35	17	12						15°					
S20R-MWLNR/L08			25	20	200	40	19	13.0						15°					
S25S-MWLNR/L08			30	25	250	36	23	16.5						12°					
S32T-MWLNR/L08	38		32	300	50	30	20	17°											
S40T-MWLNR/L08	46		40	300	60	37	24	15°											
S50U-MWLNR/L08	56		50	350	70	47	31	12°											
									MW0603	CTM513	HL1813	ML0625	L2.0 L3.0						
									MW0804	CTM617	HL1813	ML0625	L3.0						

型号 Type	刀片 Blade	规格 Specification							刀垫 Shim	压板螺钉 Plate screws	压板 Clamp	弹簧 Spring	刀垫螺钉 Shim screw	扳手 Wrench	
		ϕ Dmin	ϕ d	L	L1	H	f	α°							
S20R-DWLNR/L06	WN□□0604□□	24	20	200	40	19	13.0	15°	MW0603	/	HLD-3	TH810	M5×9P	L3.0	
S25S-DWLNR/L06		32	25	250	45	23	17.0	12°							
S32T-DWLNR/L06		40	32	300	50	30	22.0	17°							
S40T-DWLNR/L06		50	40	300	60	37	27.0	15°							
S20R-DWLNR/L08	WN□□0804□□	25	20	200	40	19	13.0	15°	MW0804	M6×21	/	HLD-1	TH810	M6×9P	L3.0
S25S-DWLNR/L08		30	25	250	36	23	16.5	12°							
S32T-DWLNR/L08		38	32	300	50	30	20	17°							
S40T-DWLNR/L08		46	40	300	60	37	24	15°							

▲更多型号可咨询，可接受高要求非标定制

2MWR

主偏角95°
Tool cutting edge angle 95°

外圆 端面 内孔

型号 Type	刀片 Blade	规格 Specification						刀垫 Shim	销钉 Pin	压板 Clamp	双头螺丝 Screw	扳手 Wrench
		D	H	S	H1	L	L1					
S25S-2MWR08-33	WN□□0804□□	25	23	33	16	250	L1<L2	/	CTM613	HL1810	MI0620	L3.0
S25S-2MWL08-33		25	23	33	16	250	L1>L2	/				
S25S-2MWN08-33		25	23	33	16	250	L1=L2	/				
S32T-2MWR08-39		32	29	39	20	300	L1<L2	WN0804	CTM617	HL1813	MI0625	
S32T-2MWL08-39		32	29	39	20	300	L1>L2					
S32T-2MWN08-39	32	29	39	20	300	L1=L2						

▲更多型号可咨询，可接受高要求非标定制

WTUNR/L 93°

主偏角93°
Tool cutting edge angle 93°

内孔车刀
Internal turning tool

型号 Type	刀片 Blade	规格 Specification							刀垫 Shim	销钉 Pin	压板 Clamp	压板螺钉 Plate screws	扳手 Wrench
		φ Dmin	φ d	L	L1	H	f	α°					
S25S-WTUNR/L16	TN□□1604□□	32	25	250	36	23	17	12°	MT1603	CT515-T	HLT-16	M5×25	L2.0 L4.0
S32T-WTUNR/L16		40	32	300	46	30	22.5	17°					
S40T-WTUNR/L16		45	40	300	56	38	26.5	15°					

▲更多型号可咨询，可接受高要求非标定制

WWLNR/L

主偏角95°
Tool cutting edge angle 95°

内孔车刀
Internal turning tool

型号 Type	刀片 Blade	规格 Specification							刀垫 Shim	销钉 Pin	压板 Clamp	压板螺钉 Plate screws	扳手 Wrench
		φ Dmin	φ d	L	L1	H	f	α°					
S25S-WWLNR/L08	WN□□0804□□	32	25	250	40	23	17	12°	MW0804	CT618-W	HLW-08	M5×25	L3.0 L4.0
S32T-WWLNR/L08		40	32	300	50	30	22	17°					
S40T-WWLNR/L08		45	40	300	60	38	27	15°					

▲更多型号可咨询，可接受高要求非标定制